











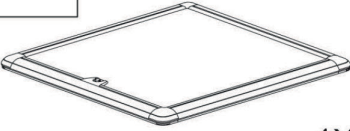
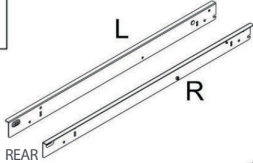
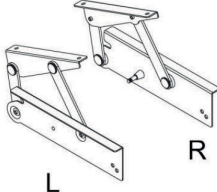
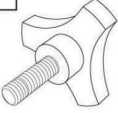

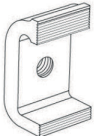
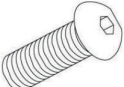

**ROAD RANGER®**

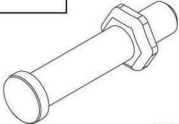
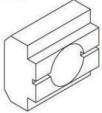
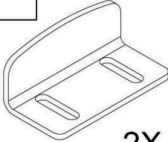
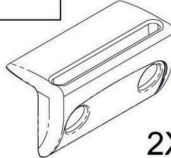
# ROAD RANGER ALUCOVER

**MONTAGEANLEITUNG**  
INSTALLATION INSTRUCTION

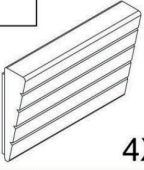
# BESTANDTEILE (K408)

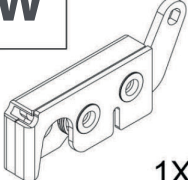
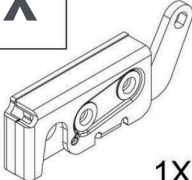
## PART LIST

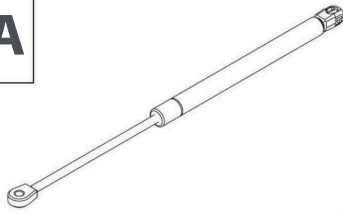
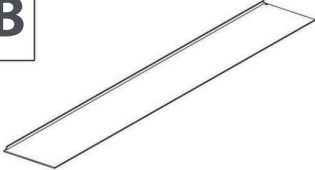
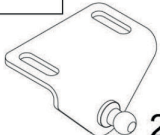
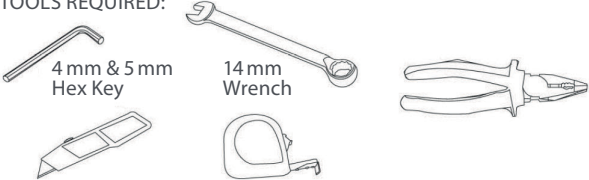
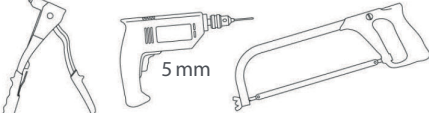
<b>A</b>  1X	<b>B</b>  1X	<b>C</b>  1X	<b>D</b>  2X		
<b>E</b>  2X	<b>F</b>  4X	<b>G</b>  M8 x 25mm 4X	<b>H</b>  M8 x 16 Stainless Steel Washer 6X	<b>I</b>  2X	<b>J</b>  M8 Nylock 4X
<b>K</b> M8 Stainless Steel Spring Washer  2X	<b>L</b>  2X	<b>M</b>  2X	<b>N</b>  2X	<b>O</b>  2X	<b>P</b>  M6 x 18 16X
<b>Q</b>  M6 x 13 mm Zinc 12X	<b>R</b>  M6 x 10 mm 12X	<b>S</b>  4X	<b>T</b>  4X	<b>U</b>  M10 x 24 mm 4X	<b>V</b>  M8 x 16 Zinc Washer 8X
<b>W</b>  1X	<b>X</b>  1X	<b>Y</b>  M5 Cable Bolt Washer & Dome Nut 2X	<b>Z</b>  2X	<b>AA</b>  2X	
<b>AB</b>  1X	<b>AC</b>  2X	<p><b>Note 1:</b> If at any stage of installation you find your sportlid to be an unacceptable fit please contact the manufacturer before continuing.</p> <p><b>Note 2:</b> If required, use Under Rail Bed Liner only.  <b>NOT FOR USE WITH OVER RAIL BED LINER!</b></p> <p>TOOLS REQUIRED:</p>  <p><b>OPTIONAL</b></p> 			

01

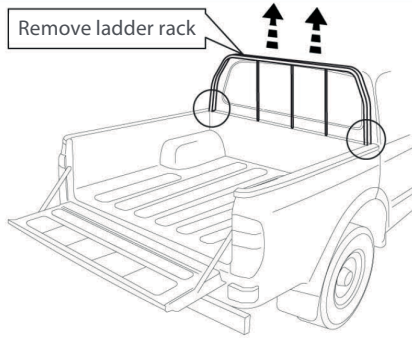

**Note 2:** If required, use Proform Under Rail Bed Liner only. Not for use with Over Rail Bed Liner.

Follow guide lines to trim liner in front corners.



02

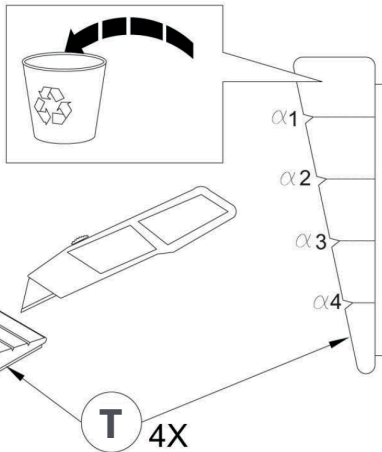

**VEHICLE MODEL**

$\alpha$

Isuzu D-Max Double & Extra Cab 2012 ATFS, ATFR	N/A - Do Not Fit
Volkswagen Amarok Double Cab 2010 2H, 2HS2	1
Ford Ranger T6 Double & Extra Cab 2011 2AB	2
Holden Colorado Double Cab 2012	N/A - Do Not Fit
Mitsubishi L200 DC Long Bed 2009 KA0T	3
Nissan Navara NP300 2016 Double & King Cab	2

03

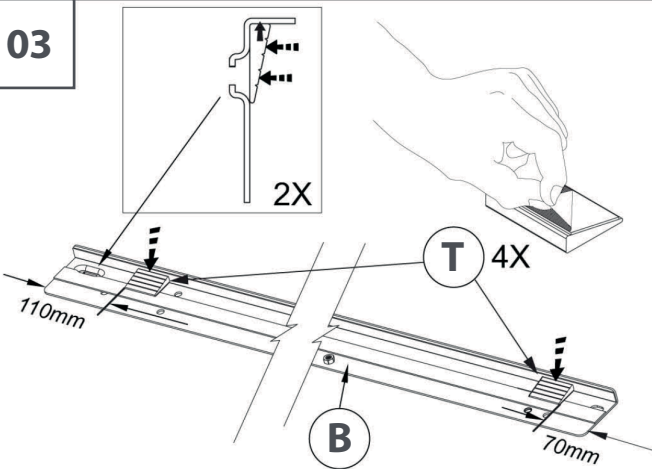

04

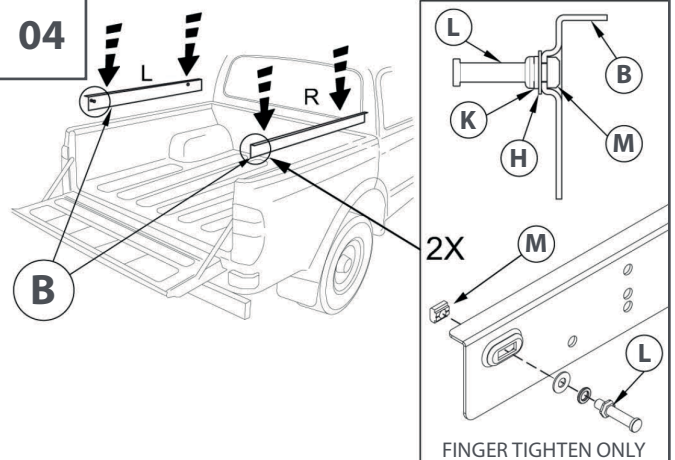

05

Place front of side mounting brackets back from inside corners of the cargo box - See table for measurement

**VEHICLE MODEL**

$\beta$   $\delta$   $\varphi$

Isuzu D-Max Double & Extra Cab 2012 ATFS, ATFR	69 mm	1	4
Ford Ranger T6 Double & Extra Cab 2011 2AB	72.4 mm	4	3
Volkswagen Amarok Double Cab 2010 2H, 2HS2	70.4 mm	3	1
Holden Colorado Double Cab 2012	63 mm	4	2
Mitsubishi L200 DC Long Bed 2009 KA0T	70.4 mm	4	2
Nissan Navara NP300 2016 Double & King Cab	80 mm	1	7

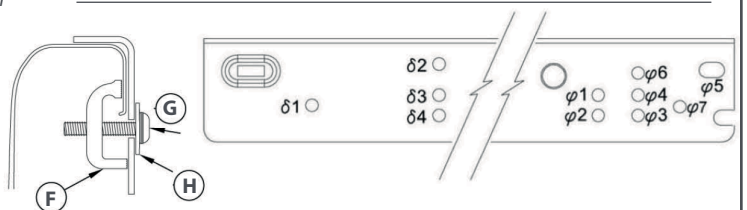
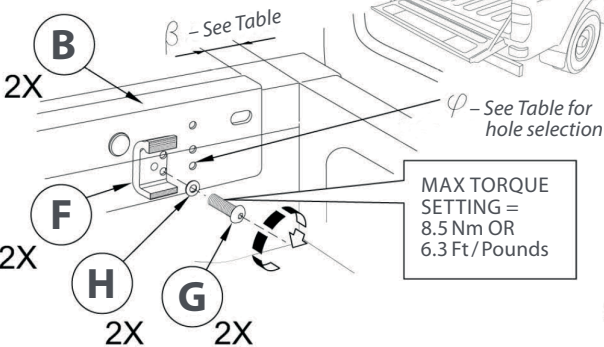

06

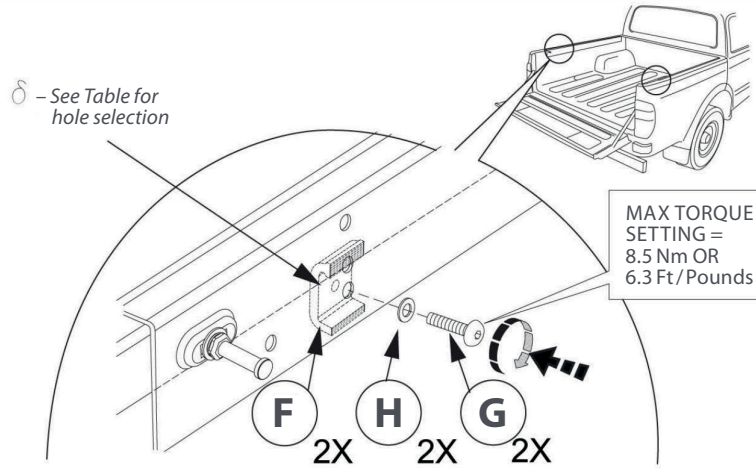

07

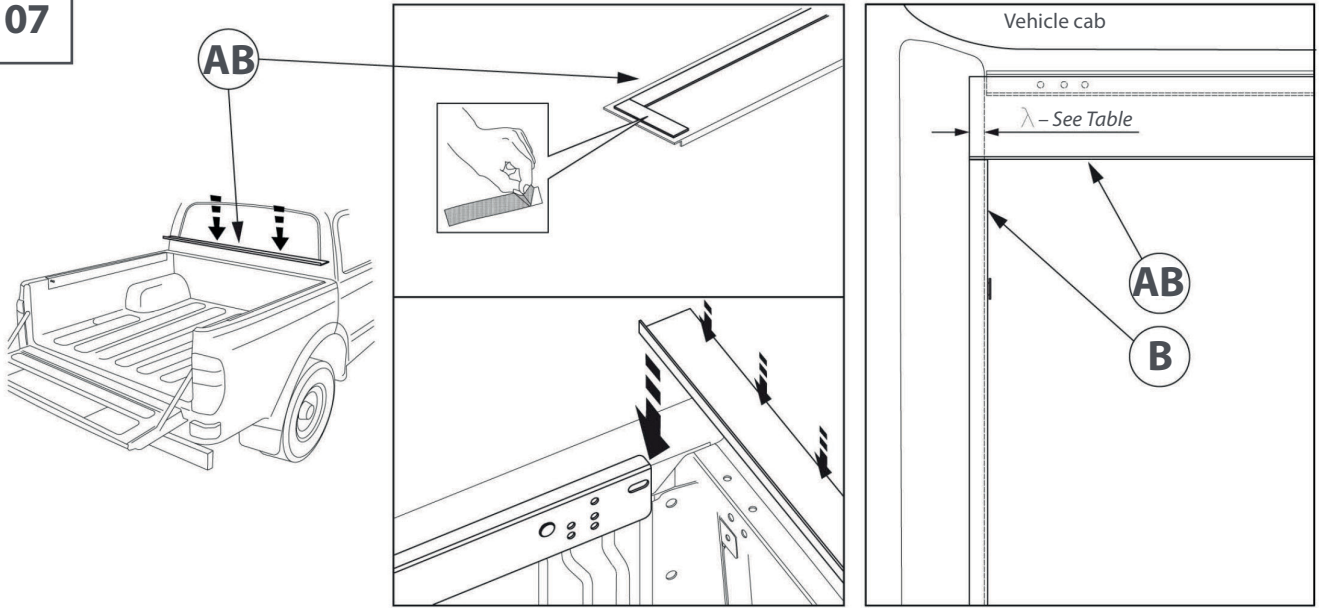

**VEHICLE MODEL**

$\lambda$

Isuzu D-Max Double & Extra Cab 2012 ATFS, ATFR	28 mm
Ford Ranger T6 Double & Extra Cab 2011 2AB	37.5 mm
Volkswagen Amarok Double Cab 2010 2H, 2HS2	27 mm
Holden Colorado Double Cab 2012	28 mm
Mitsubishi L200 DC Long Bed 2009 KA0T	24 mm
Nissan Navara NP300 2016 Double & King Cab	25 mm



DO NOT apply below 15°C.  
Apply pressure to part. Adhesive is pressure activated.  
Allow 3 hrs minimum to cure before installing lid.

08

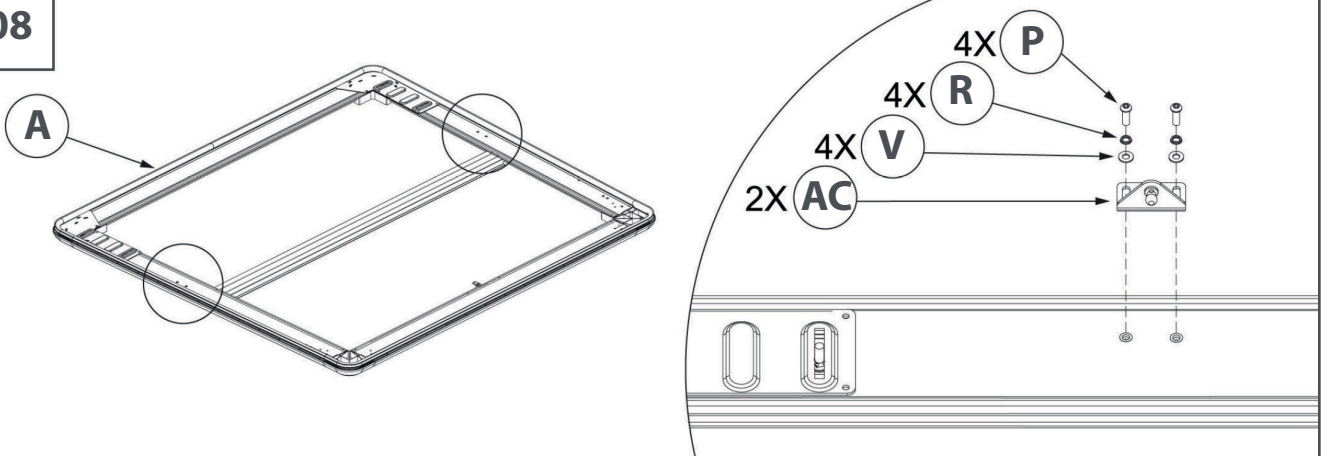

09

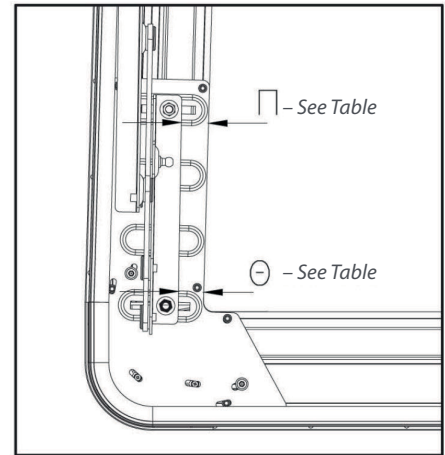
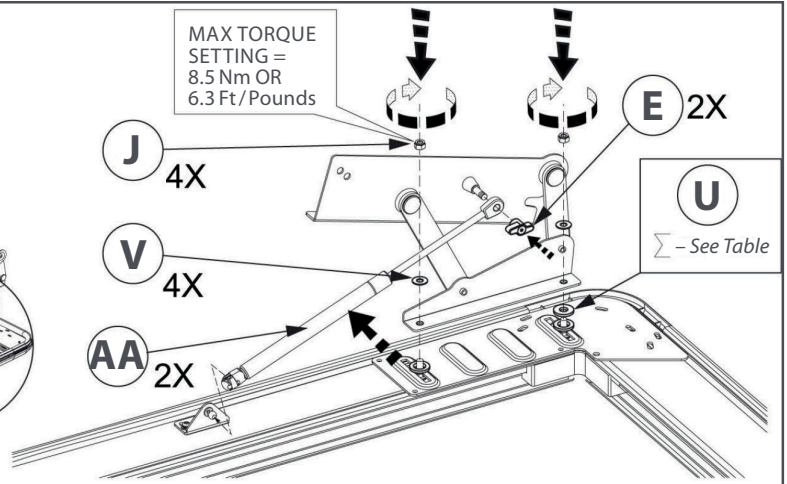
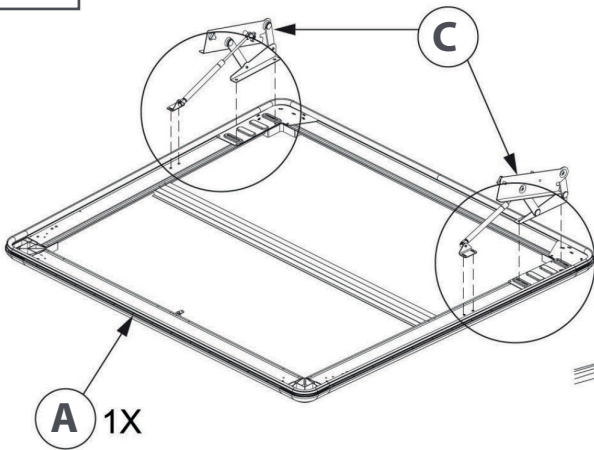

**VEHICLE MODEL**

VEHICLE MODEL	Π	Θ	Σ
Isuzu D-Max Double & Extra Cab 2012 ATFS, ATFR	26 mm	29 mm	
Ford Ranger T6 Double & Extra Cab 2011 2AB	16 mm	16 mm	2 Qty
Volkswagen Amarok Double Cab 2010 2H, 2HS2	22 mm	22 mm	1 Qty
Holden Colorado Double Cab 2012	26 mm	29 mm	
Mitsubishi L200 DC Long Bed 2009 KA0T	30 mm	30 mm	
Nissan Navara NP300 2016 Double & King Cab	25 mm	25 mm	

10

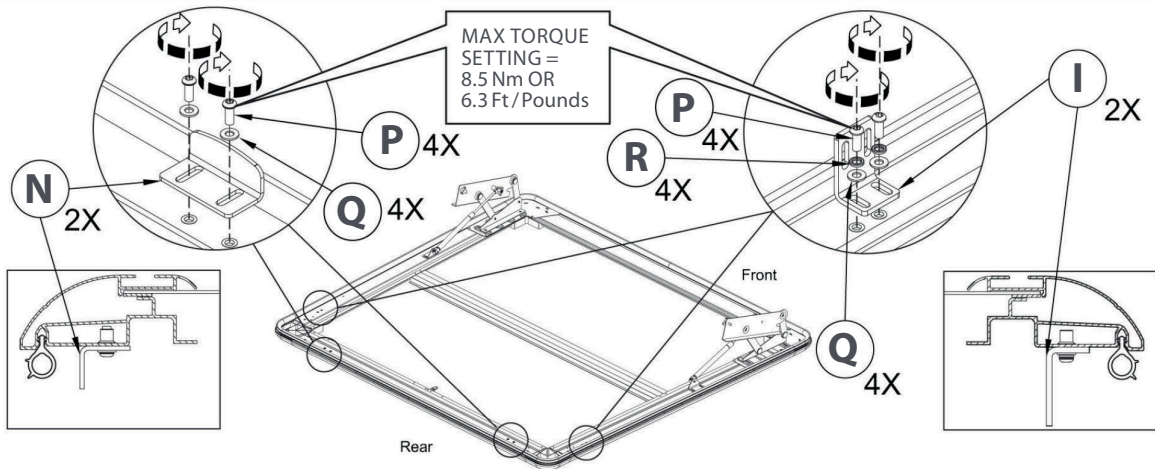

11

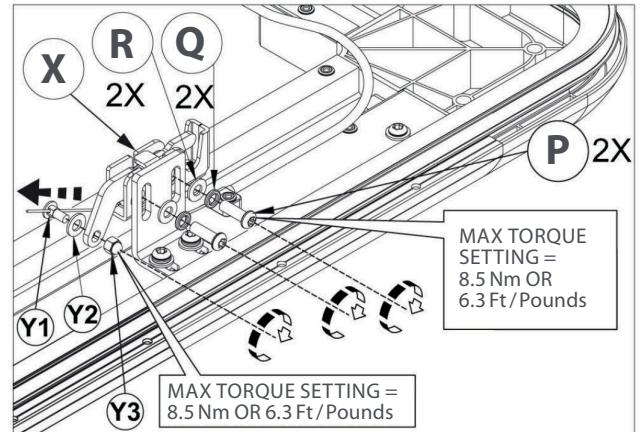
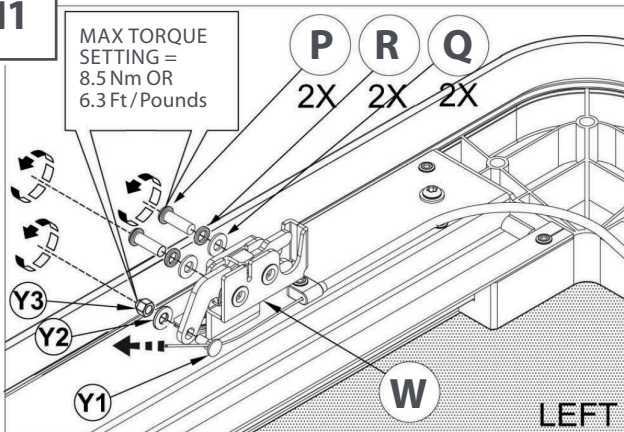

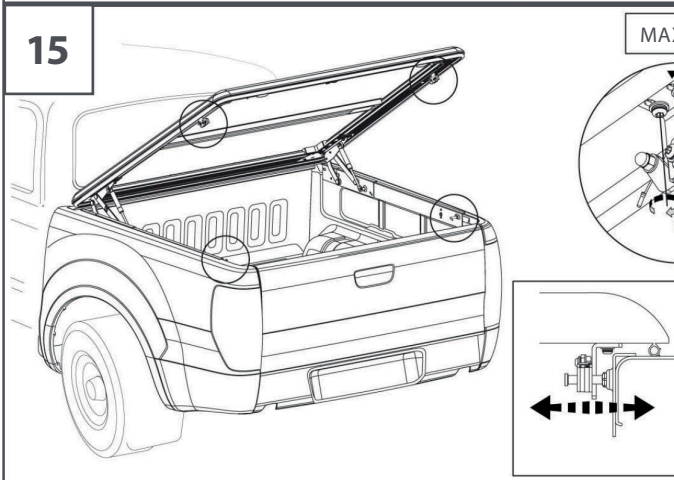
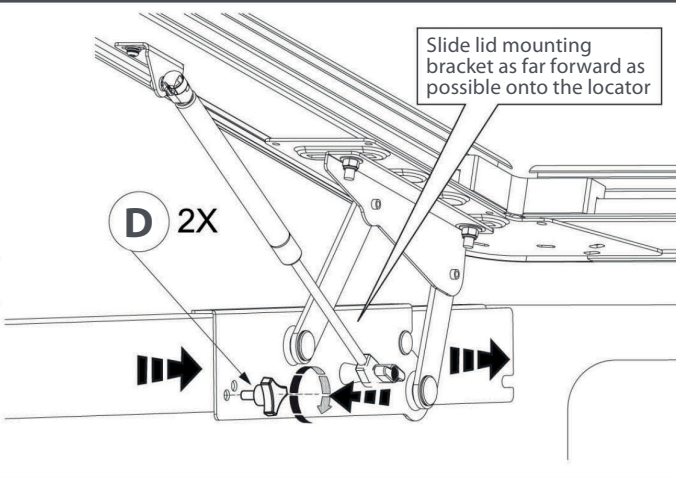
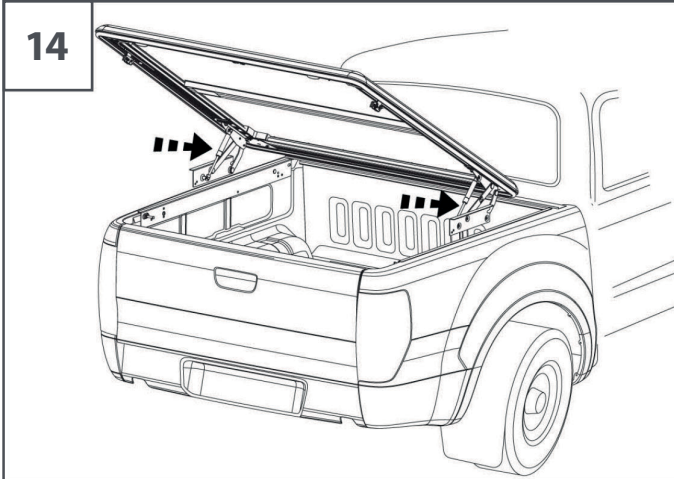
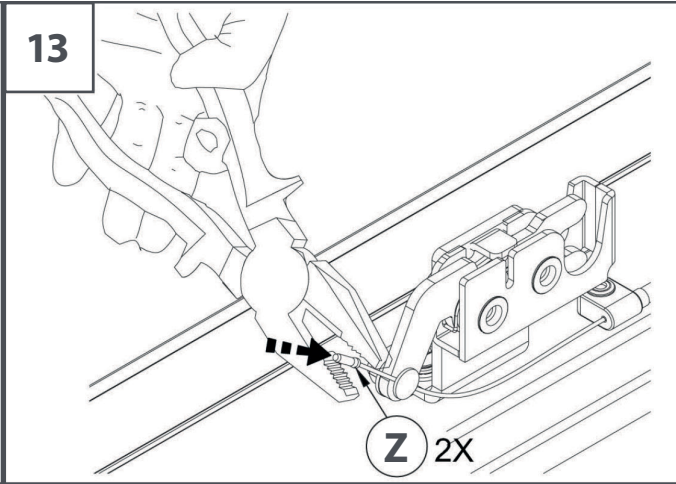
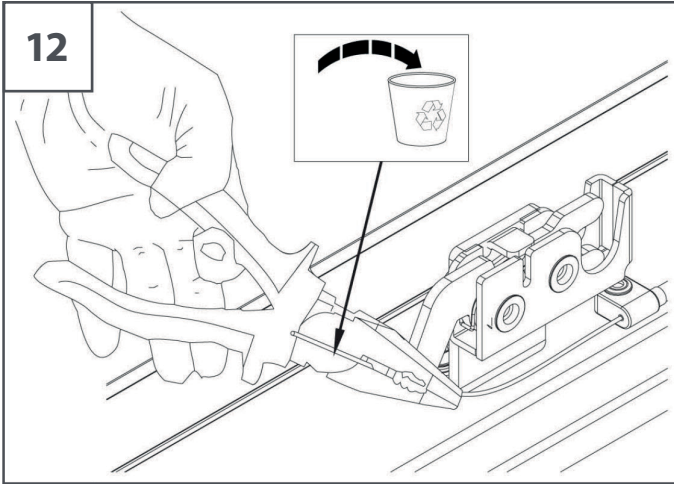

MAX TORQUE SETTING = 8.5 Nm OR 6.3 Ft/Pounds

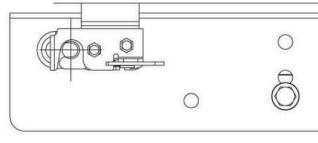
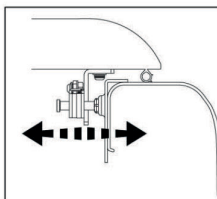
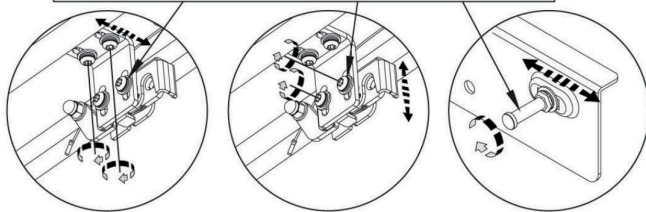

Adjust latch bracket, latch height and pin location to align pin with centre of latch. Adjust cable tension to achieve correct latching. **IMPORTANT:** Ensure seal contacts vehicle in all areas

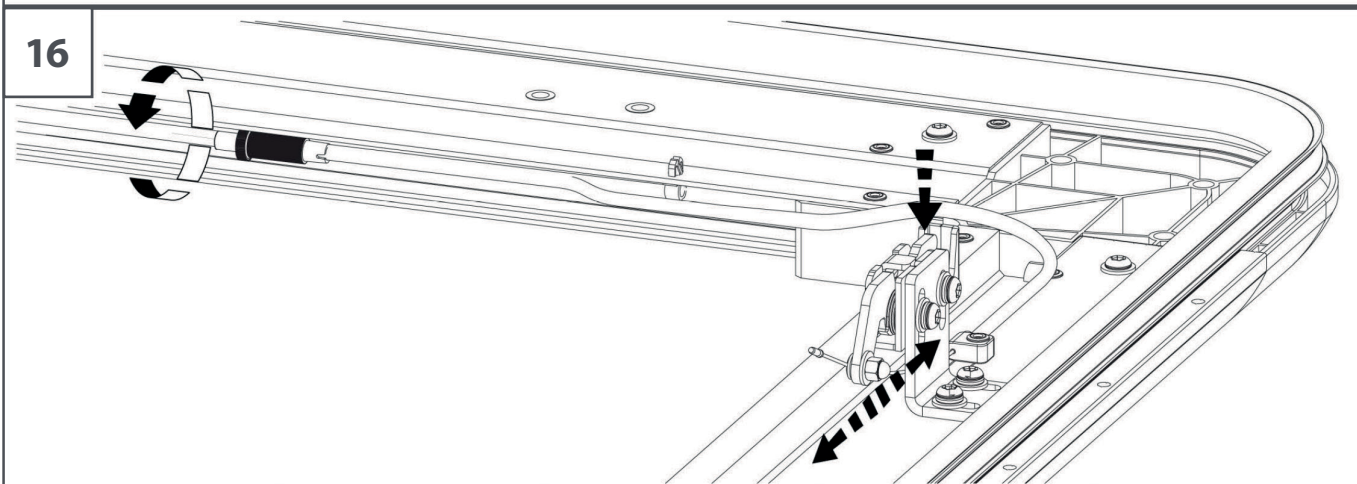

17

DO NOT apply below 15°C.  
Apply pressure to part. Adhesive is pressure activated.  
Allow 3 hrs minimum to cure.

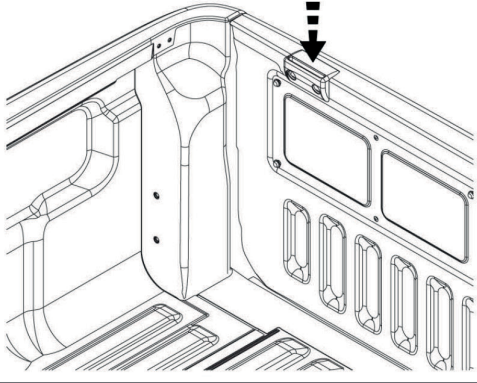
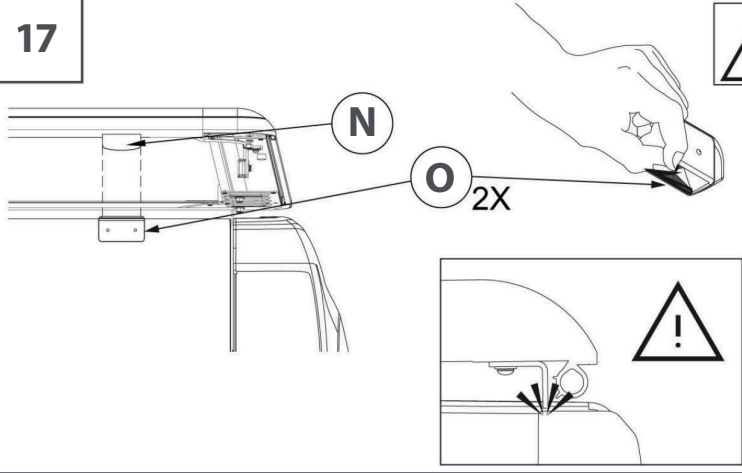

18

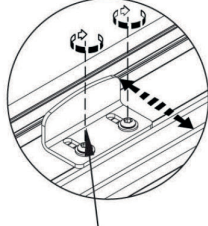
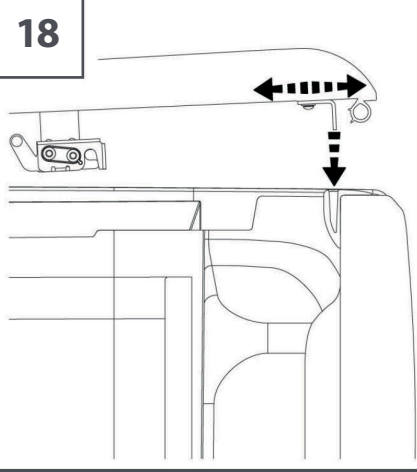

MAX TORQUE  
SETTING =  
8.5 Nm OR  
6.3 Ft/Pounds

19

OPTIONAL

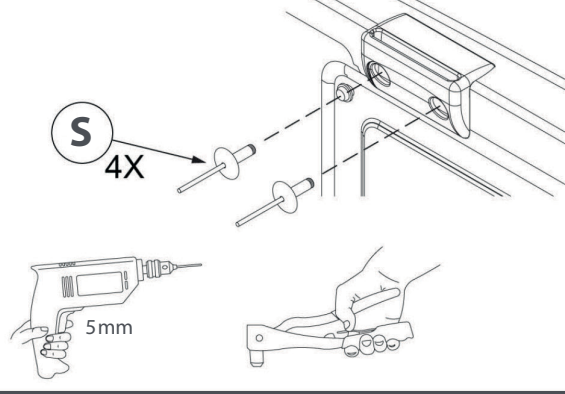

20

! Insure hinge is not twisted. Adjust connection to lid if necessary.

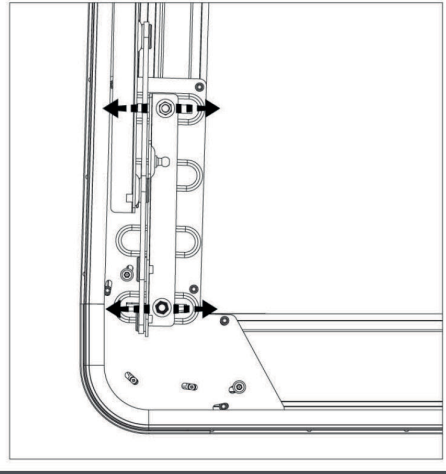
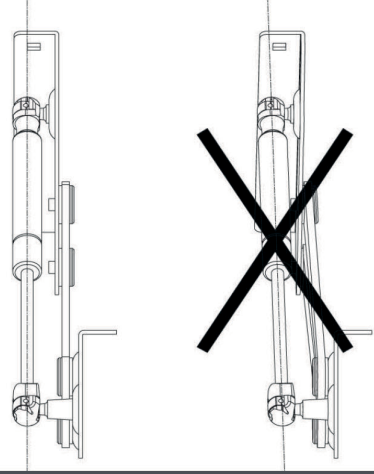

21

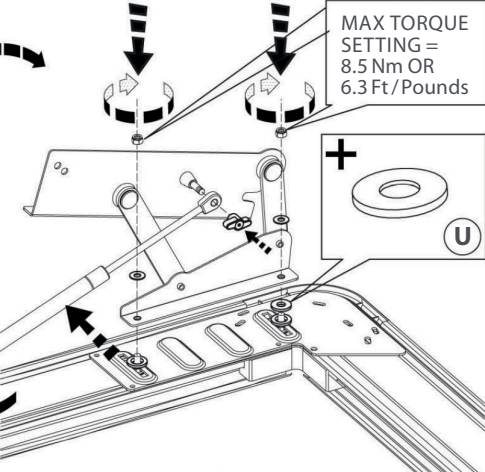
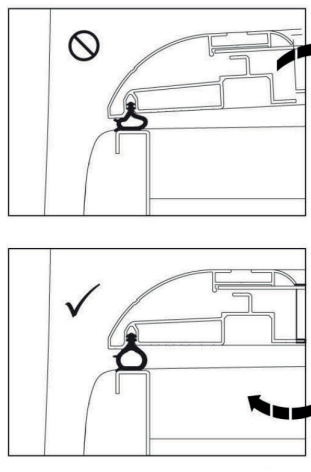
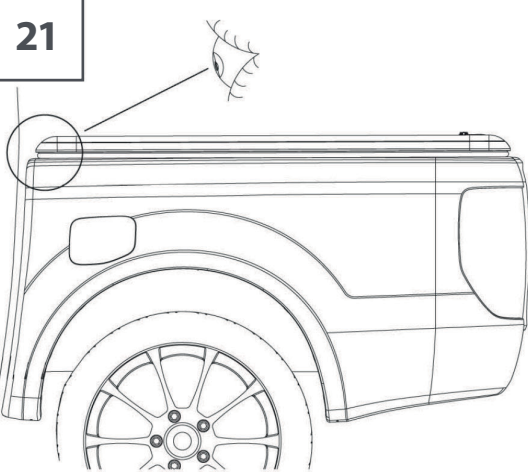

22

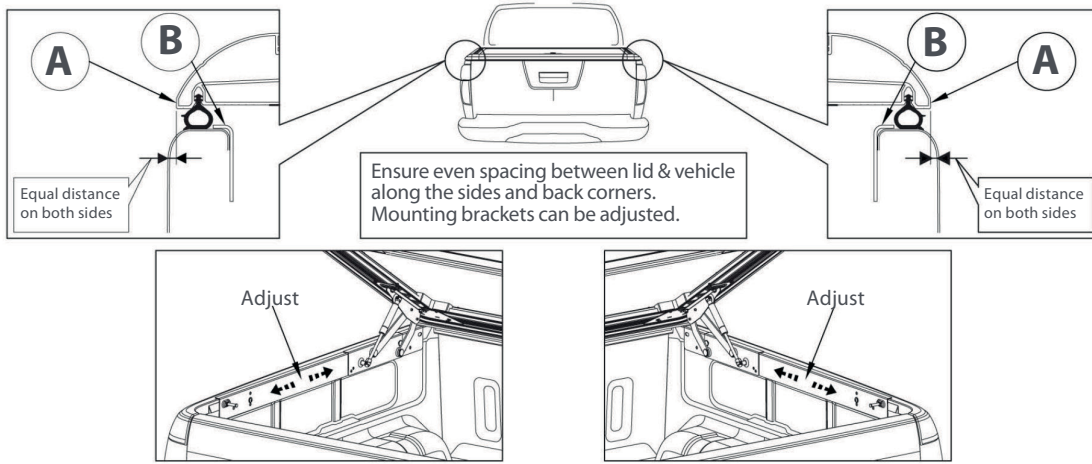

After installation carefully and thoroughly clean all debris from the inside of the cargo box.  
**Retain these instructions for future reference.**

# CAUTION!

- NEVER allow people or animals under the closet cover
- Do not place unsealed solvents or chemicals under the cover
- Do not stand or place heavy objects on the cover
- Do not open lid when under load
- Close the cover before operating the vehicle
- Do not allow oil, solvents or chemicals to contact the cover
- Clean only with a mild detergent and water solution













# ISUZU NISSAN NAVARA TOYOTA HILUX VOLKSWAGEN AMAROK



Item Code: **RUP/470/IX**  
Stainless Steel Medium Bar

# ISUZU NISSAN NAVARA TOYOTA HILUX VOLKSWAGEN AMAROK

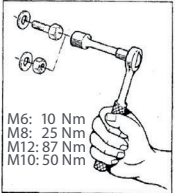
BESTANDTEILE PART LIST				
<b>A</b>  TBCEI 8X25 x 4	<b>B</b>  Ø 8 x 4	<b>C</b>  Ø 8 x 4	<b>D</b>  TCEI 10X25 x 4	<b>E</b>  TSPEI M10X25 x 4
<b>F</b>  M6 x 4	<b>G</b>  Cappelletti M 6 x 4	<b>H</b>  VIPLA Ø 80 x 4	<b>I</b>  TE 6X15 x 4	<b>L</b>  BIG Ø 6 GRAND x 4
<b>M</b>  Ø 6 x 4	<b>N</b> AS7/SX x1	<b>O</b> AS7/DX x1	<b>P</b> PS7/SX x1	<b>Q</b> PS7/DX x1
<b>R</b> RLS/7TR x2	<b>S</b> RLB/06 x2	<b>T</b> RLB Ø76 x2	 <p>M6: 10 Nm M8: 25 Nm M12: 87 Nm M10: 50 Nm</p>	

# ISUZU NISSAN NAVARA TOYOTA HILUX VOLKSWAGEN AMAROK

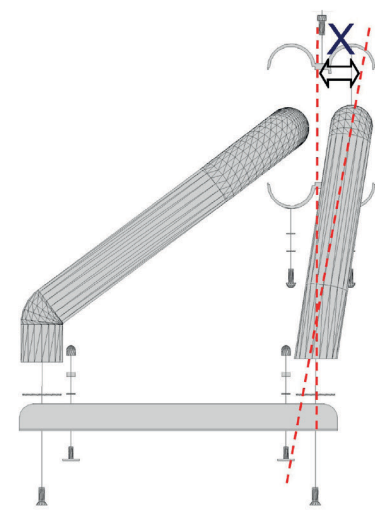
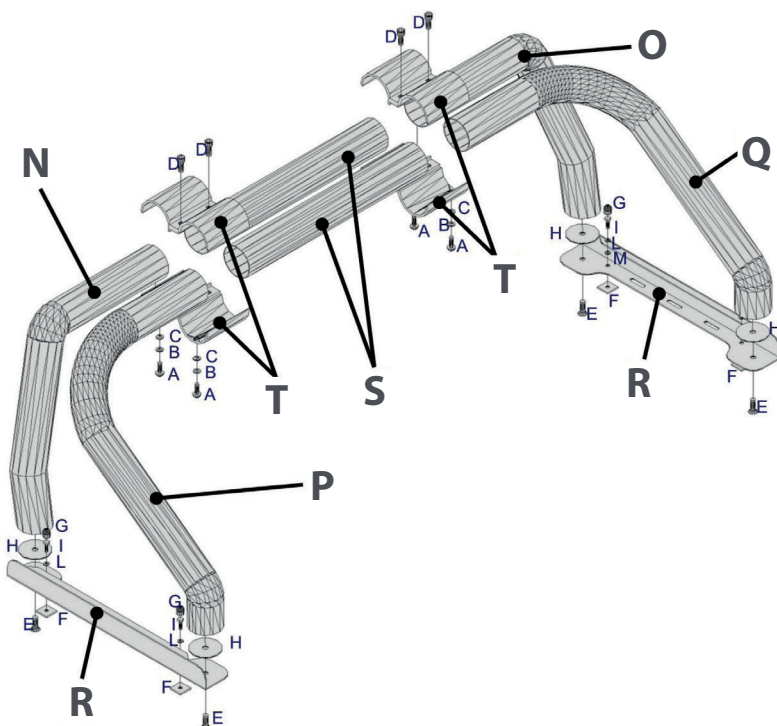

**WARNING:** fit the N and O front bends as shown in the drawing.

# ROAD RANGER®

## VIELSEITIGKEIT DURCH DESIGN & AUSSTATTUNG VARIETY IN DESIGN & CONFIGURATION

Änderungen vorbehalten. Abbildungen können vom endgültigen Produkt abweichen.  
Sämtliche Abbildungen / Fotos sind Eigentum der  
**Dr. Höhn GmbH**, Künzelsauer Straße 13, 74653 Ingelfingen,  
T: +49 (0) 79 40 92 02 - 0, [roadranger@hoehn.de](mailto:roadranger@hoehn.de)

Subject to change. Pictures may differ from the final product.  
All images / photos property of  
**Dr. Höhn GmbH**, Künzelsauer Straße 13, 74653 Ingelfingen,  
T: +49 (0) 79 40 92 02 - 0, [roadranger@hoehn.de](mailto:roadranger@hoehn.de)

Für weitere und immer aktuelle Informationen können Sie uns gerne unter  
[www.roadranger.de](http://www.roadranger.de) besuchen.

For more details and updated information please visit [www.roadranger.de](http://www.roadranger.de).

Ihr Road Ranger Team  
Your Road Ranger Team

**GESTALTUNG UND GRAFIKDESIGN**  
GRAPHIC DESIGN

christina richter visuelle kommunikation, stuttgart  
[www.christina-richter.com](http://www.christina-richter.com)