

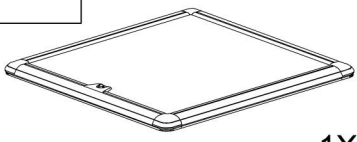

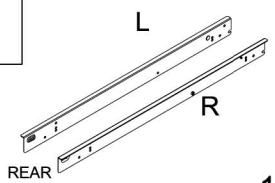

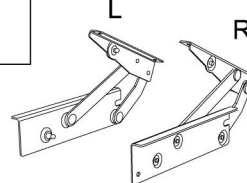

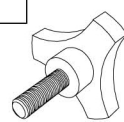

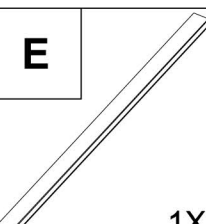
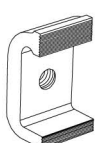
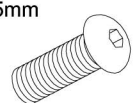

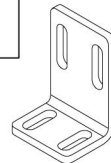

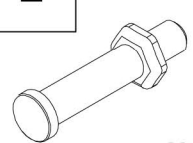
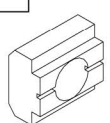
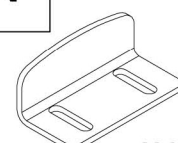
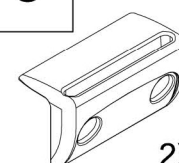

# ROAD RANGER®

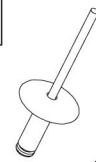
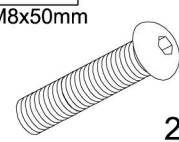
## INSTALLATION INSTRUCTIONS K404

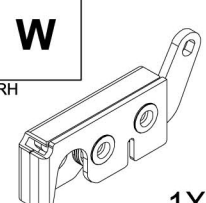
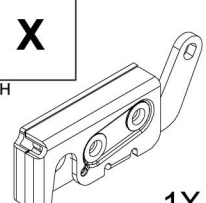
<b>A</b>  1X	<b>B</b>  REAR 1X	<b>C</b>  1X	<b>D</b>  2X		
<b>E</b>  1X	<b>F</b>  2X	<b>G</b> M8x25mm  2X	<b>H</b> M8 x16 Stainless Steel Washer  6X	<b>I</b>  2X	<b>J</b> M8 Nylock  4X
<b>K</b> M8 Stainless Steel Spring Washer  2X	<b>L</b>  2X	<b>M</b>  2X	<b>N</b>  2X	<b>O</b>  2X	<b>P</b> M6x18  12X
<b>Q</b> M6x13mm Zinc  12X	<b>R</b> M6x10mm  8X	<b>S</b>  4X	<b>T</b> M8x50mm  2X	<b>U</b> M10x24mm  4X	<b>V</b> M8 x16 Zinc Washer  4X
<b>W</b> RH  1X	<b>X</b> LH  1X	<b>Y</b> M5 Cable Bolt, Washer & Dome Nut  2X	<b>Z</b>  2X	<b>AA</b>  2X	<b>AB</b>  2X

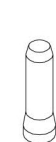
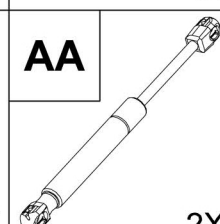
**Note 1:** If at any stage of installation you find your sportlid to be an unacceptable fit please contact the manufacturer before continuing.

**Note 2:** If required, use Under Rail Bed Liner only. **NOT FOR USE WITH OVER RAIL BED LINER!**

**Tools Required:**

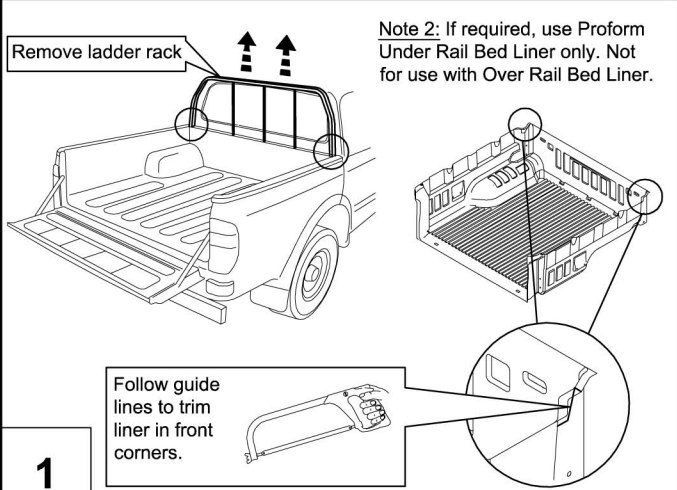
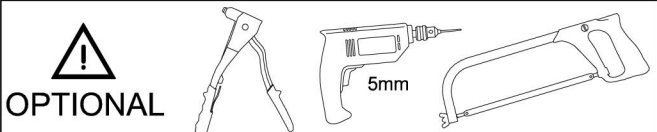
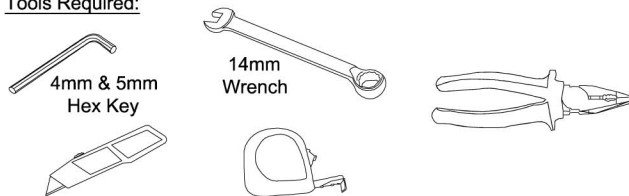

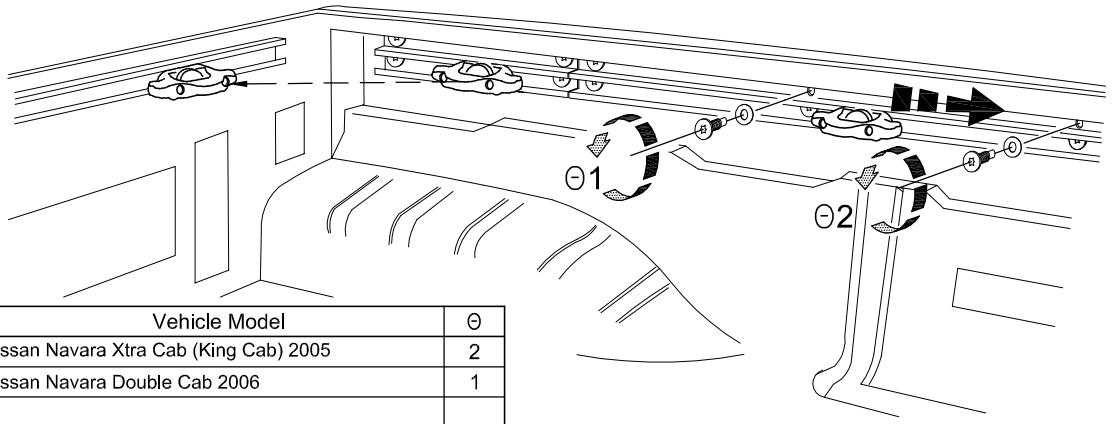

Vehicle Model	Θ
Nissan Navara Xtra Cab (King Cab) 2005	2
Nissan Navara Double Cab 2006	1

2

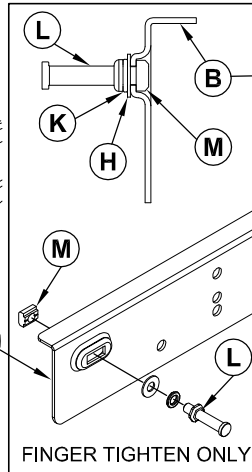
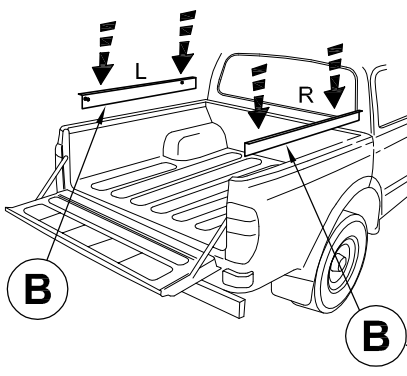

FINGER TIGHTEN ONLY

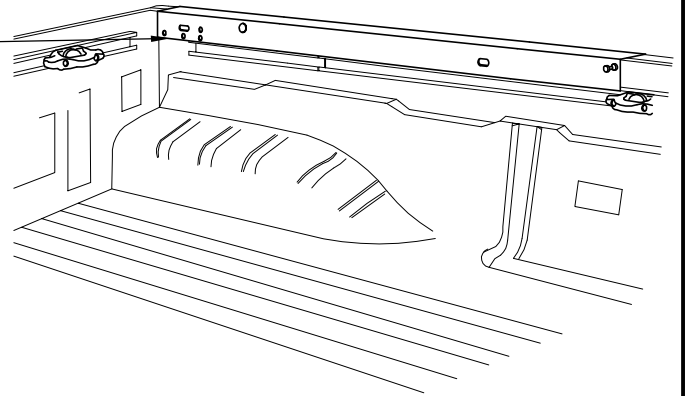

3

Place front of side mounting brackets back from inside corners of the cargo box

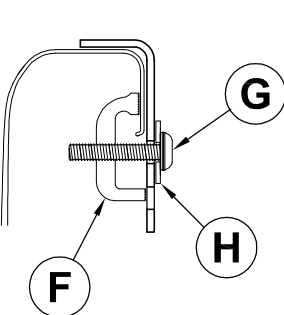
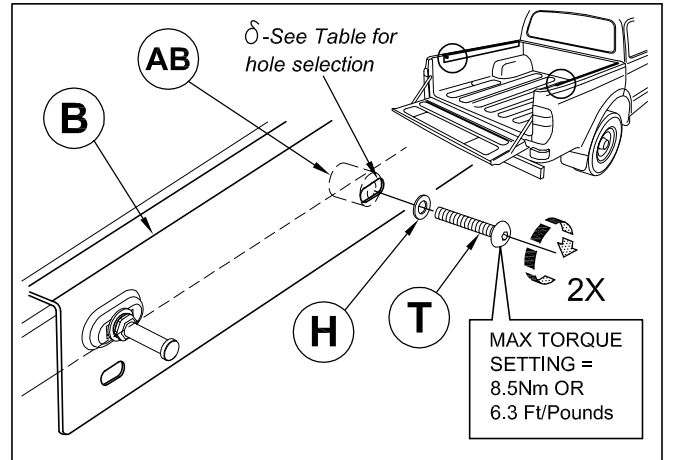
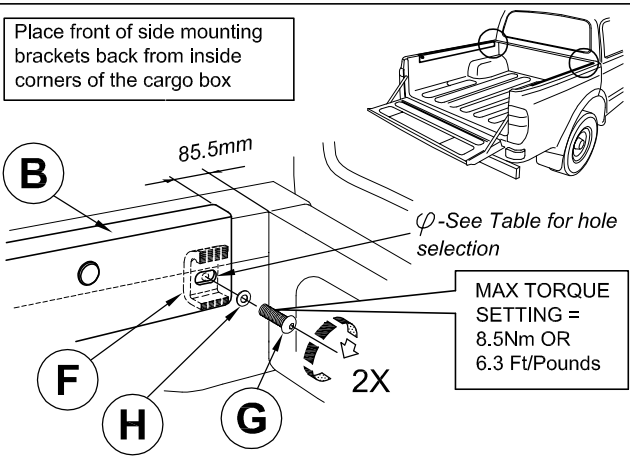

Vehicle Model	$\beta$	$\delta$	$\varphi$
Nissan Navara Xtra Cab (King Cab) 2005	70.4mm	1	1
Nissan Navara Double Cab 2006	70.4mm	2	1

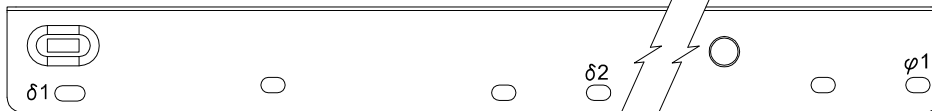
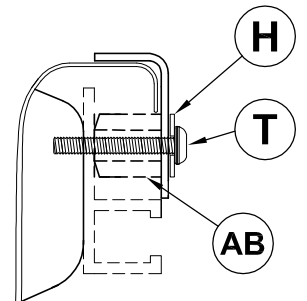

4

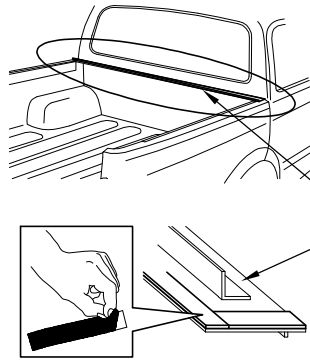

**E**

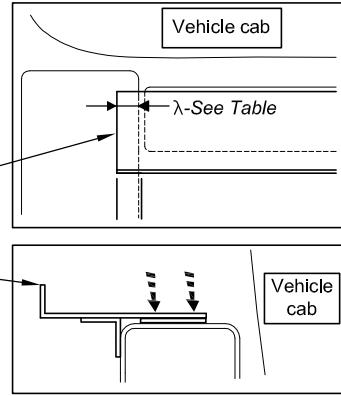

**5**



DO NOT apply below 15°C.  
Apply pressure to part. Adhesive is pressure activated.  
Allow 3hrs minimum to cure before installing lid

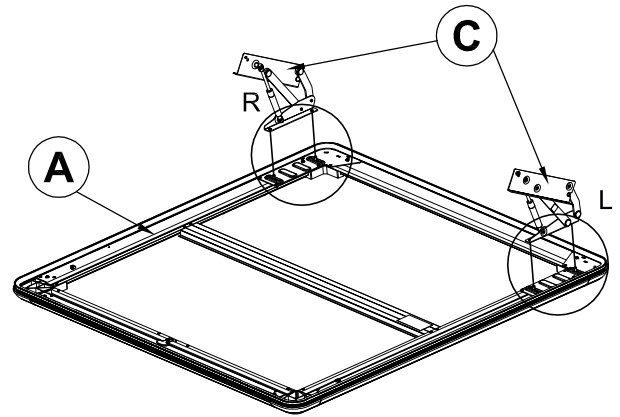
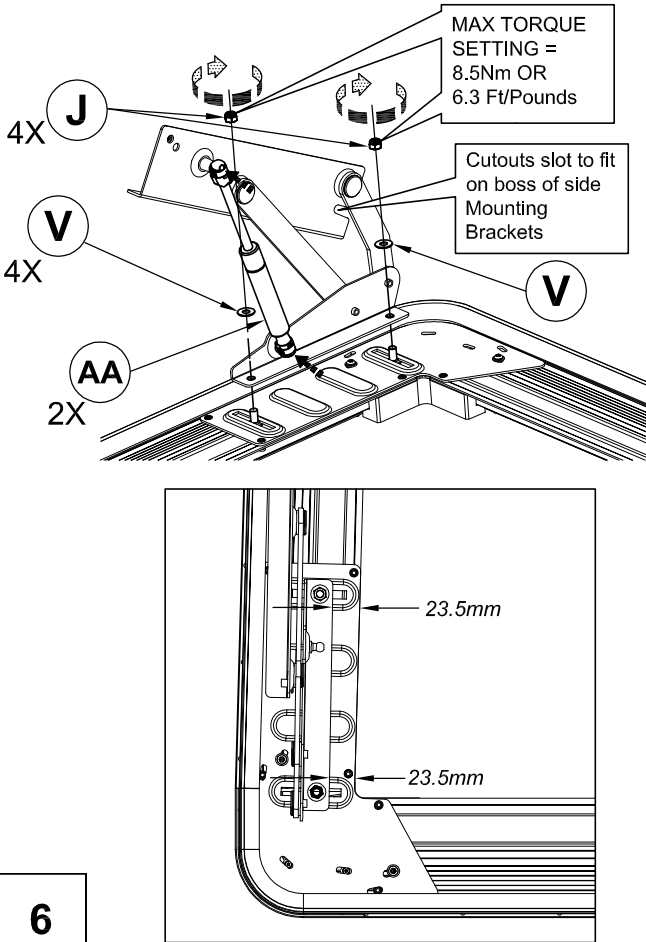

**6**

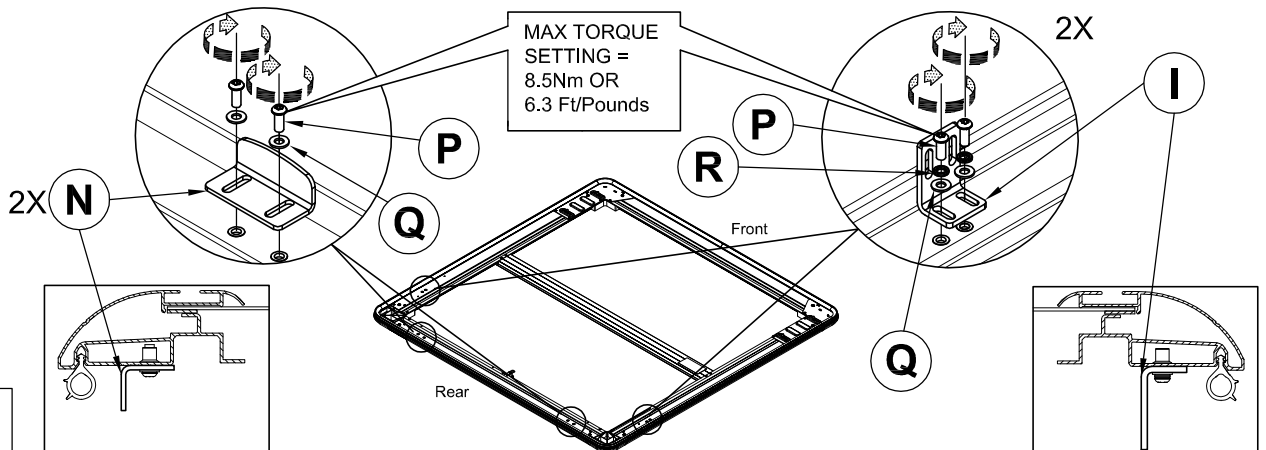

**7**

Fitting Kit Number	Product	Revision	Date	Page
K404		4	23-10-2013	3 of 6

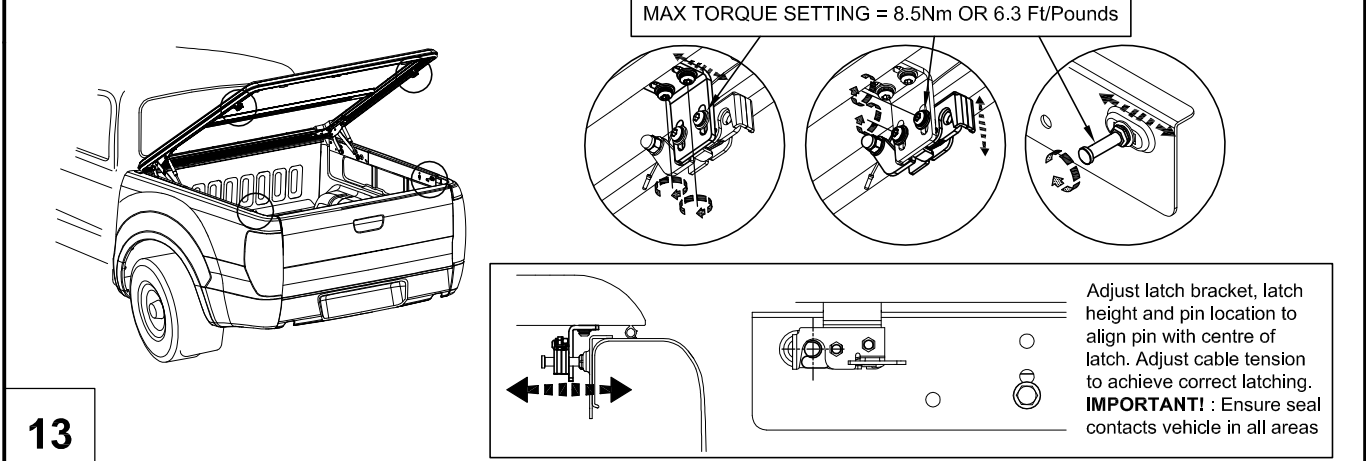
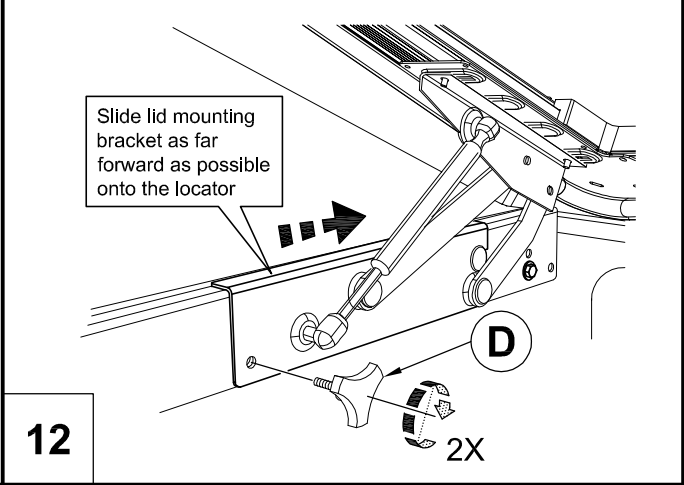
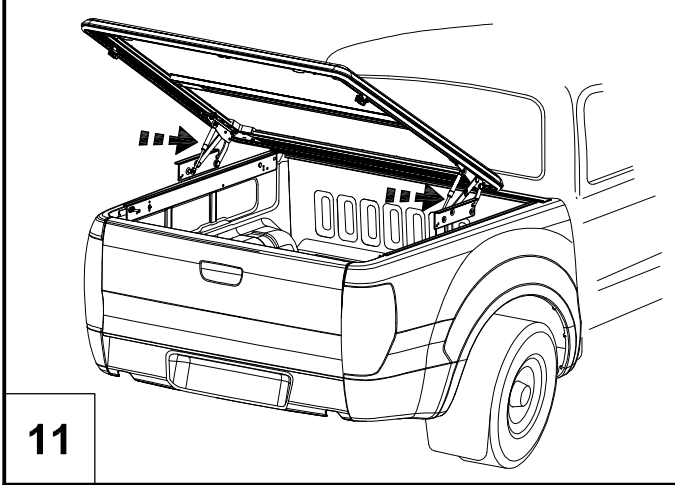
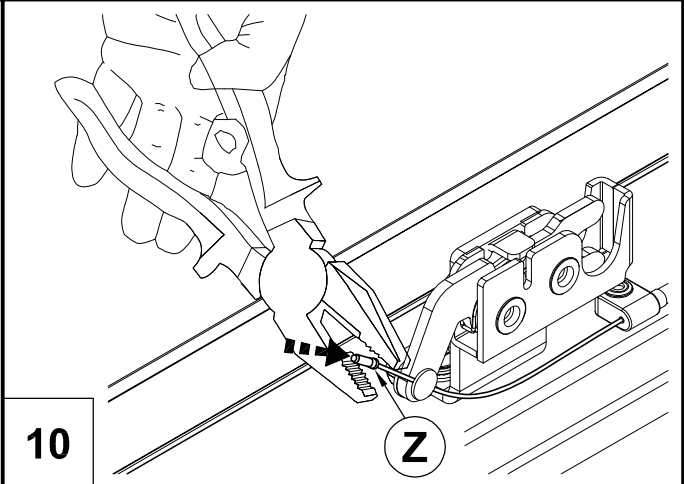
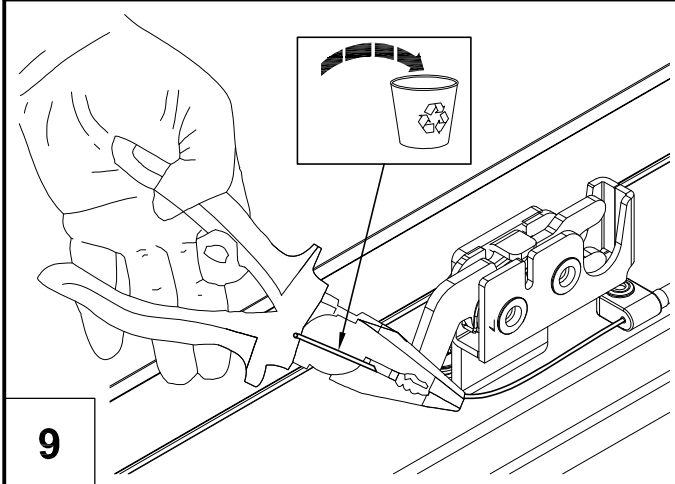
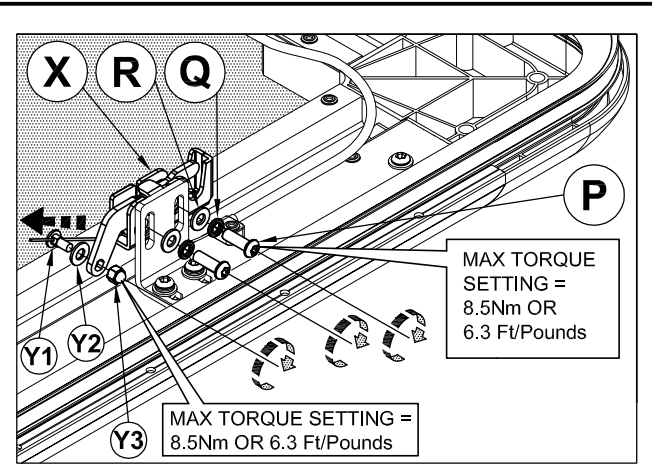
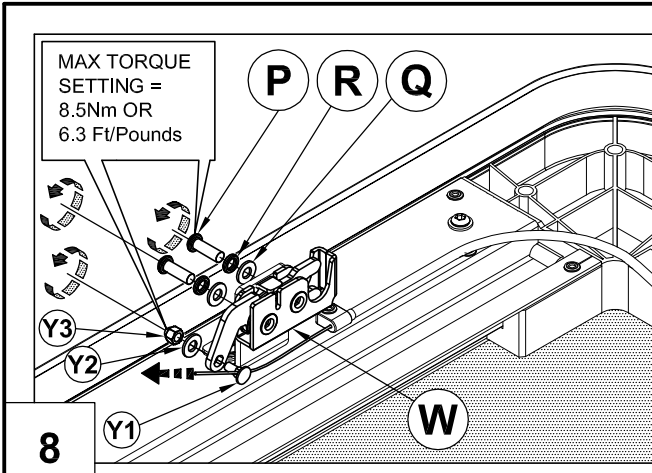

Adjust latch bracket, latch height and pin location to align pin with centre of latch. Adjust cable tension to achieve correct latching. **IMPORTANT!** : Ensure seal contacts vehicle in all areas

Fitting Kit Number	Product	Revision	Date	Page
K404		4	23-10-2013	4 of 6

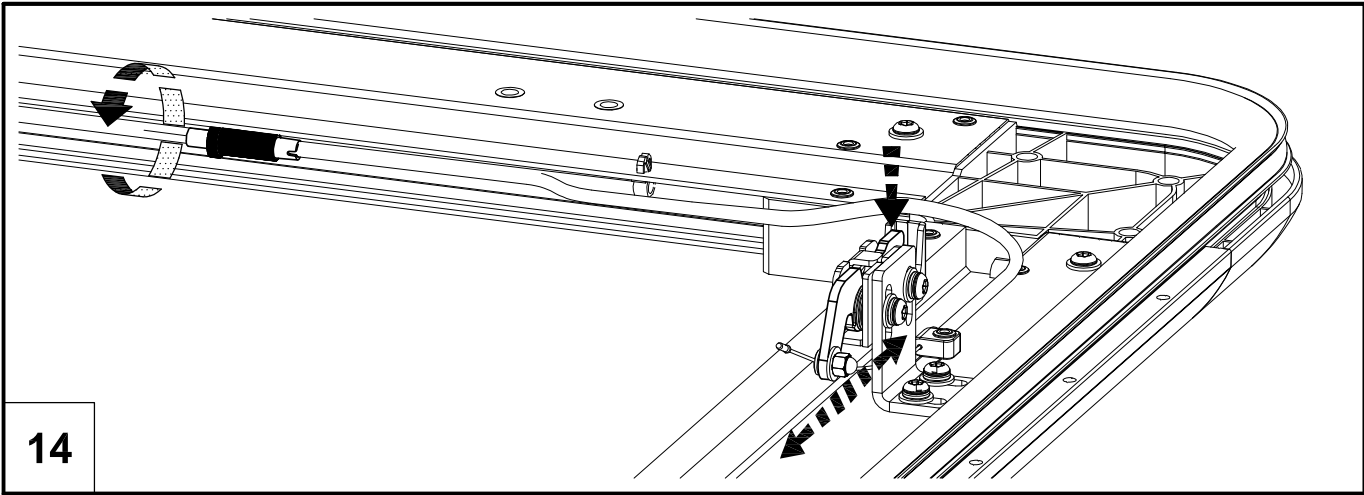

14

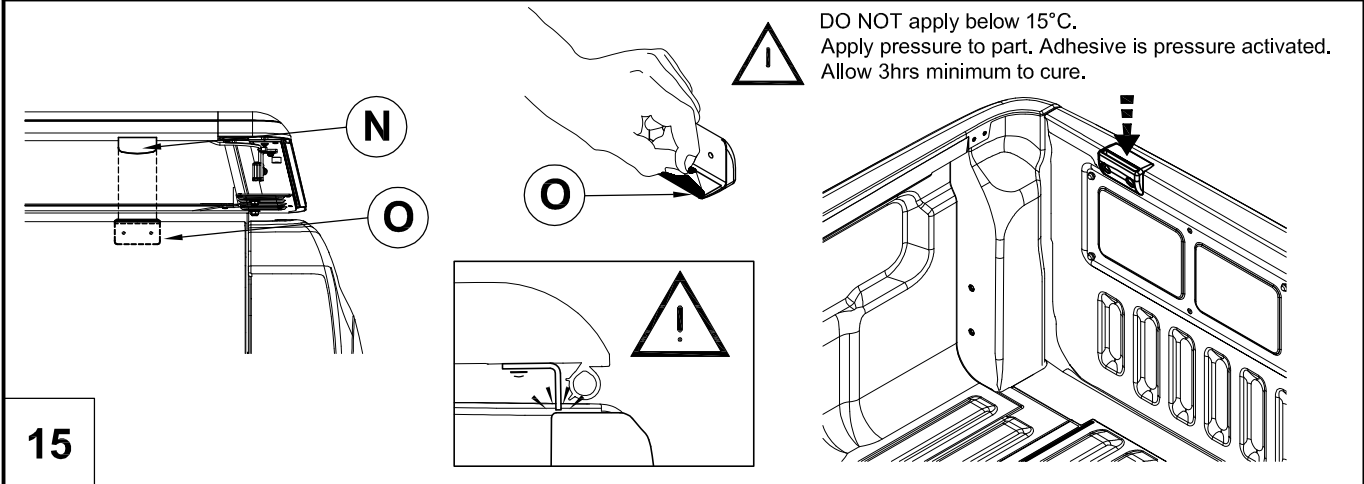

DO NOT apply below 15°C.  
Apply pressure to part. Adhesive is pressure activated.  
Allow 3hrs minimum to cure.

15

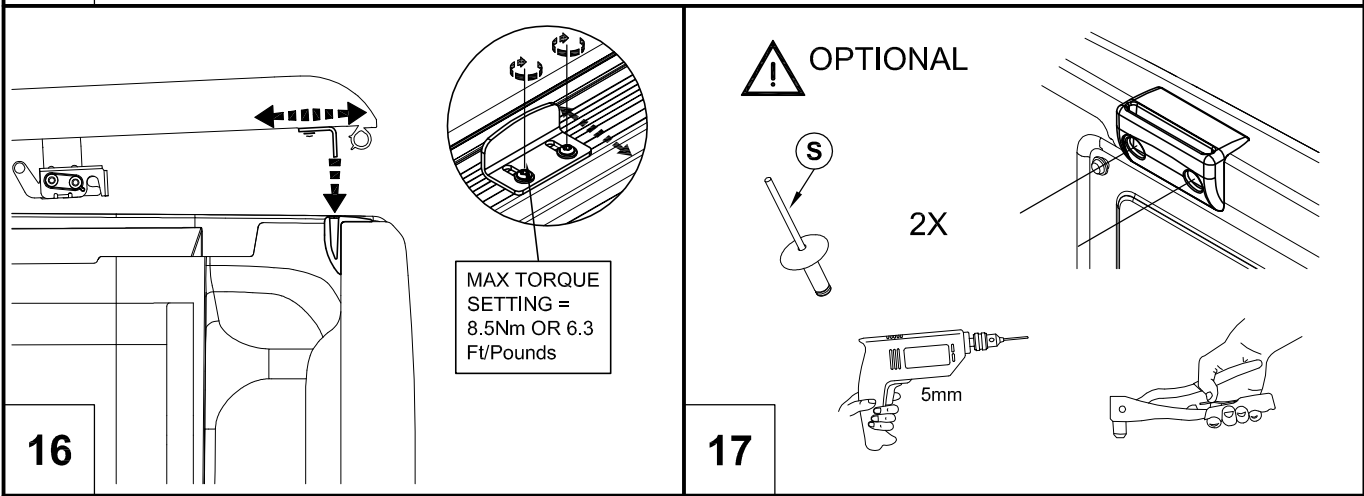

MAX TORQUE  
SETTING =  
8.5Nm OR 6.3  
Ft/Pounds

OPTIONAL

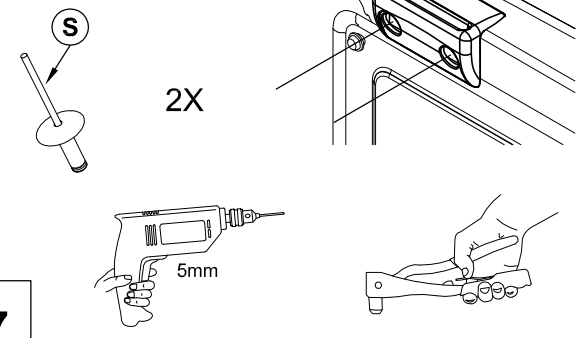

16

17

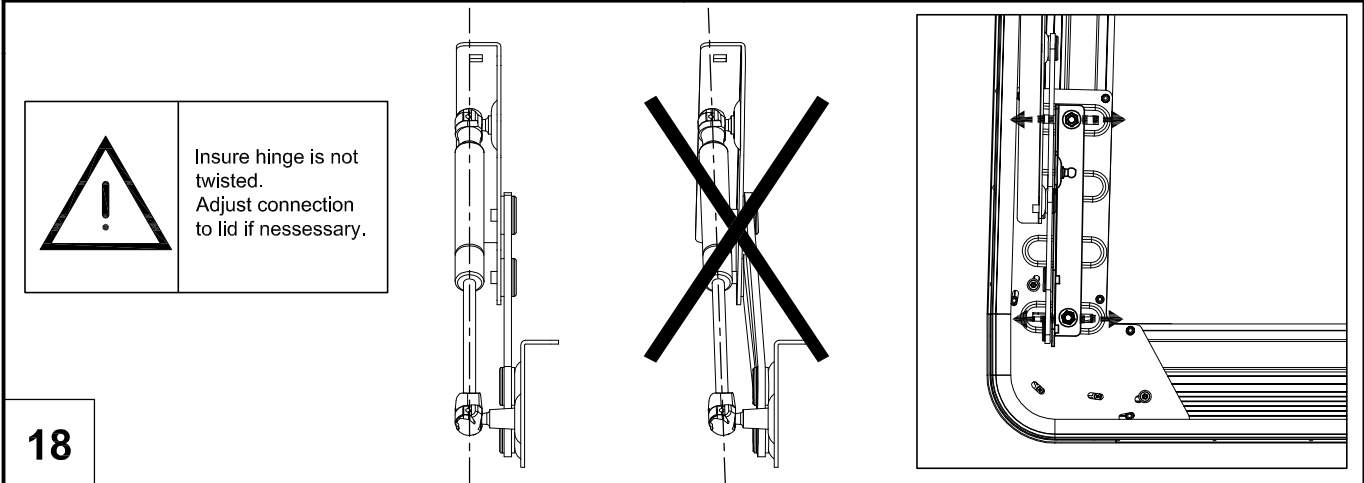

Insure hinge is not  
twisted.  
Adjust connection  
to lid if necessary.

18

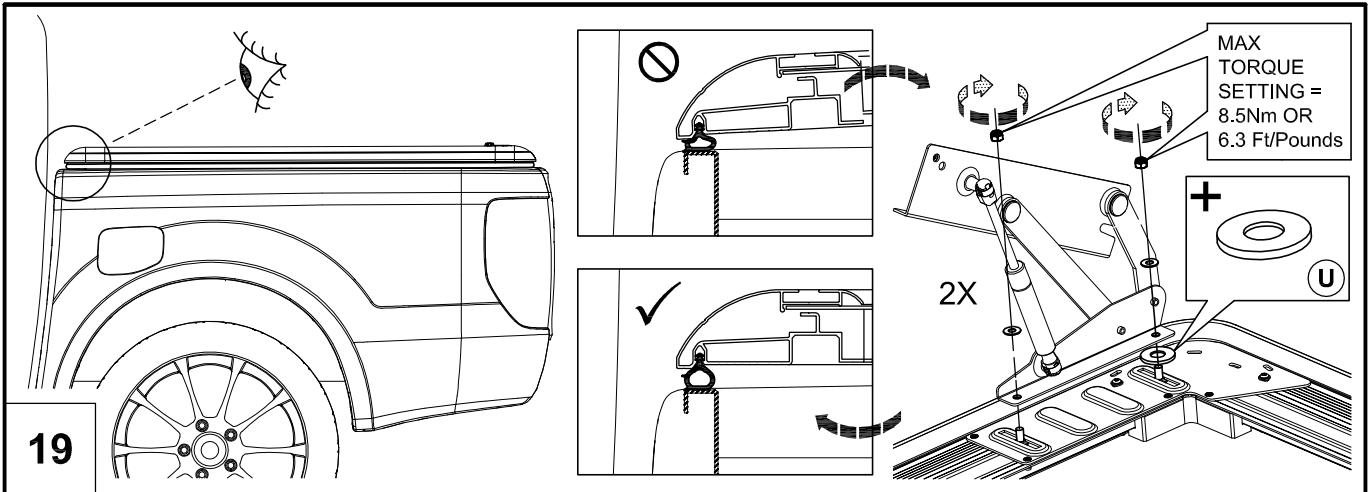

19

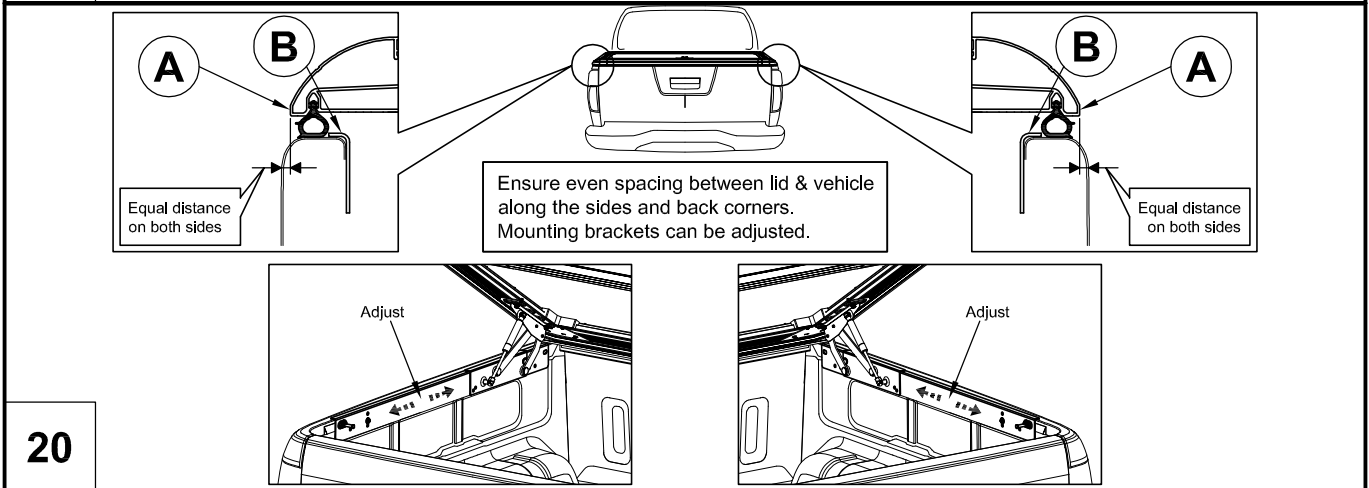

20

After installation carefully and thoroughly clean all debris from the inside of the cargo box.  
**Retain these instructions for future reference**



# CAUTION!

- NEVER allow people or animals under the closed cover
- Do not place unsealed solvents or chemicals under the cover
- Do not stand or place heavy objects on the cover
- Do not open lid when under load.
- Close the cover before operating the vehicle
- Do not allow oil, solvents or chemicals to contact the cover
- Clean only with a mild detergent and water solution