

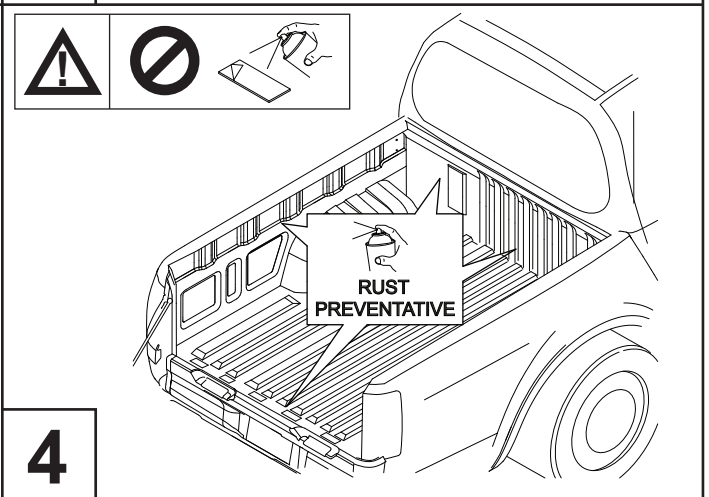

INSTALLATION INSTRUCTIONS (576)
Over Rail Liner
Ford-Ranger T6-2011-Single Cab

| | | | | |
|-----------------------------|------------------------------|------------------------------|-----------------------------|-----------------------------------|
| A X1 | B X1 | C X6 | D X11 | |
| E 10x3/4" X4 | F X4 | G X2 | H M8x20mm X16 | I X4 (2L + 2R) |
| J 8x16x8mm X4 | K M8x21x3mm X4 | L X2 (1L + 1R) | M M8x0.8 X4 | ◊ = EXISTING PART ○ = NEW PART |

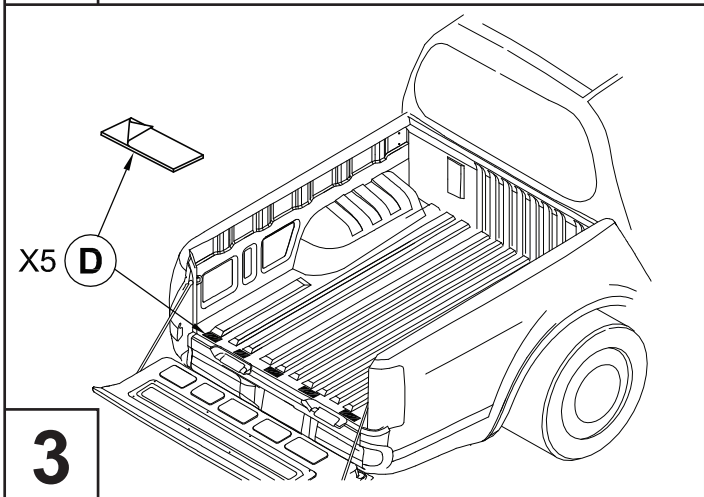
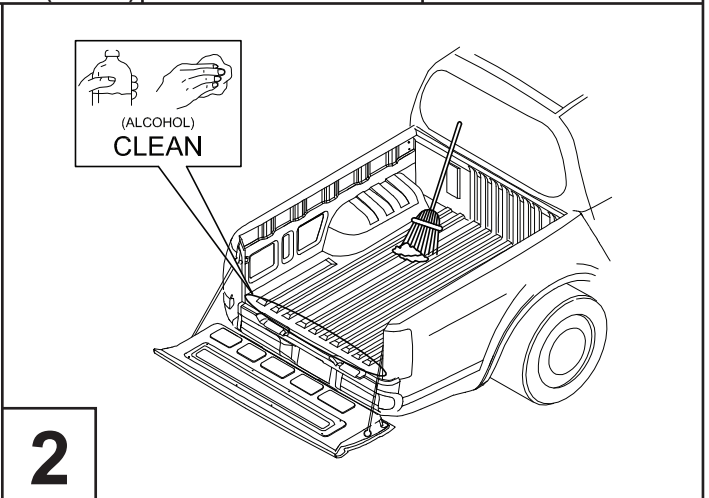
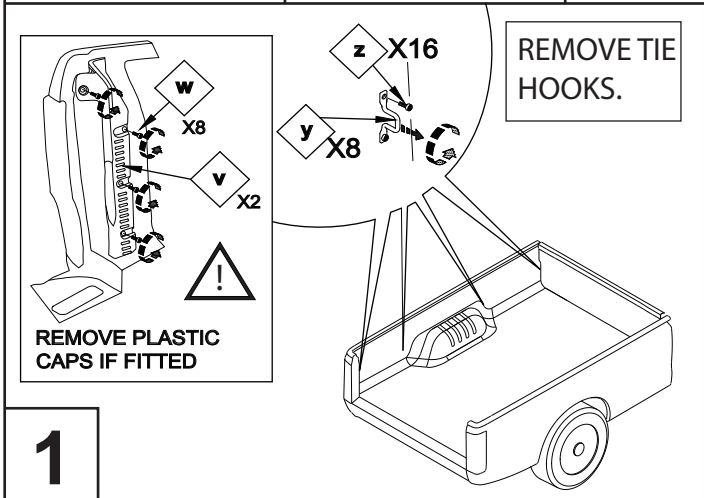

| Fitting Kit Number | Manufacturer | Model Type | Year | Stockist | Cab Size | Product | Revision | Date | Page |
|--------------------|--------------|------------|------|-------------|----------|----------|----------|----------|--------|
| K576 | Ford | Ranger | 2011 | General Use | SC | OR Liner | 1 | 24/01/14 | 1 of 4 |

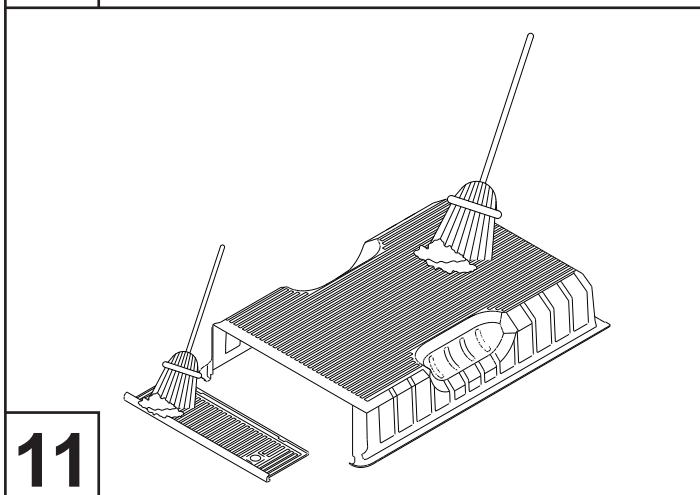
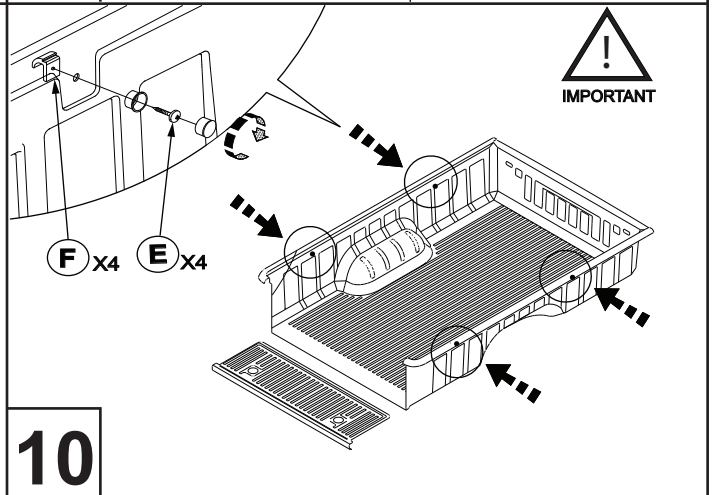
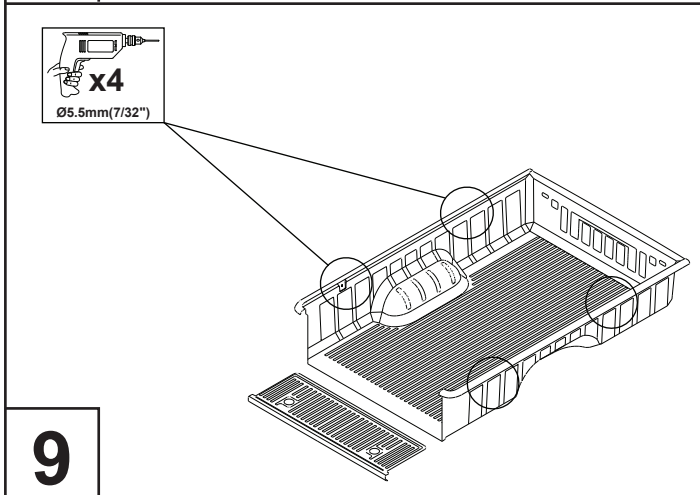
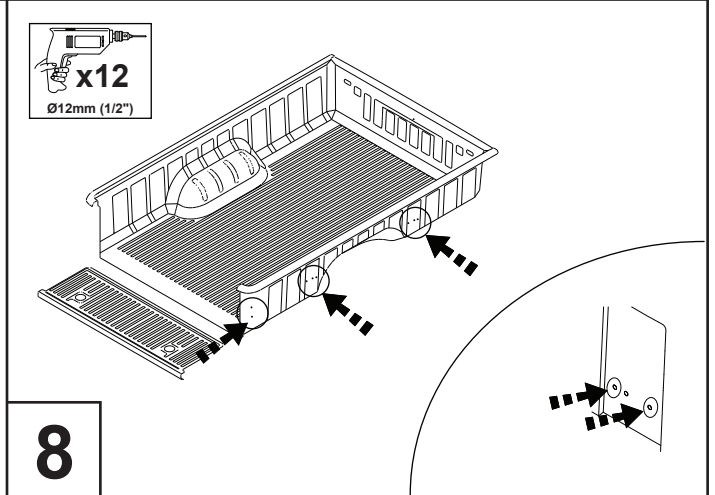
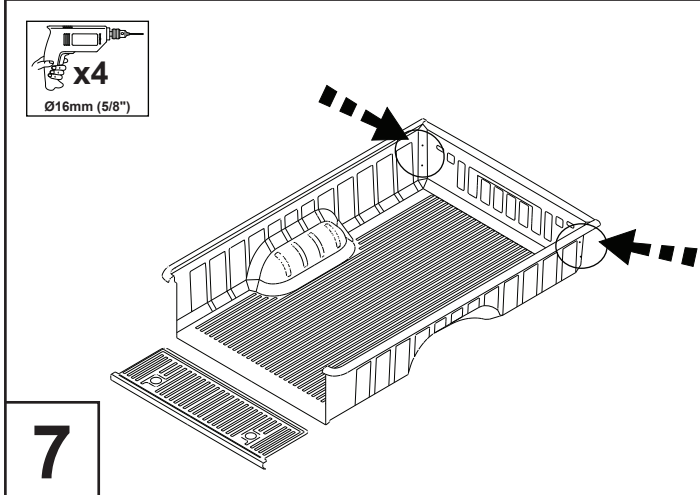
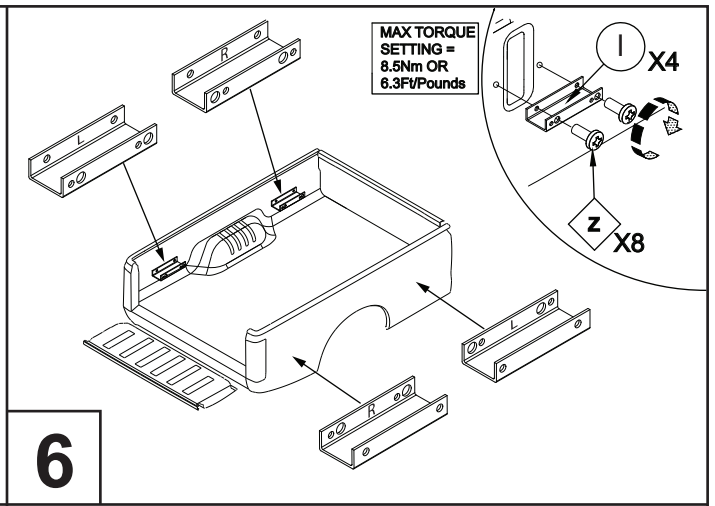
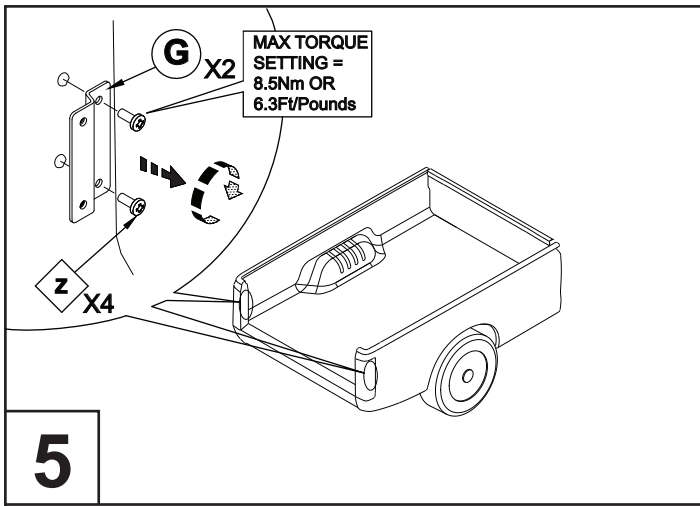

| Fitting Kit Number | Manufacturer | Model Type | Year | Stockist | Cab Size | Product | Revision | Date | Page |
|--------------------|--------------|------------|------|-------------|----------|----------|----------|----------|--------|
| K576 | Ford | Ranger | 2011 | General Use | SC | OR Liner | 1 | 24/01/14 | 2 of 4 |

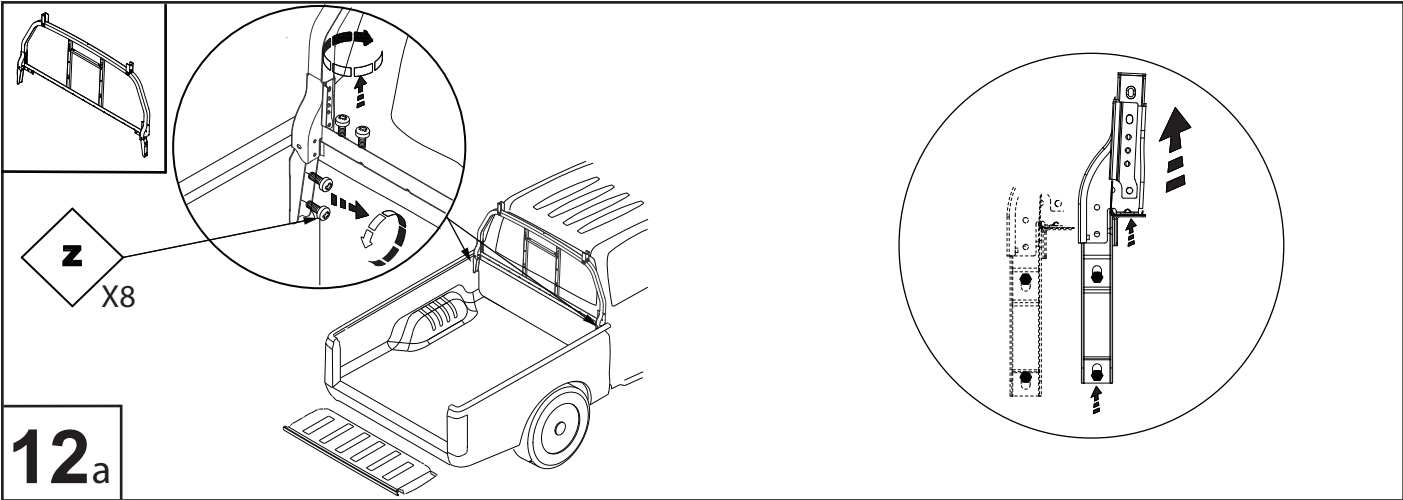

12_a

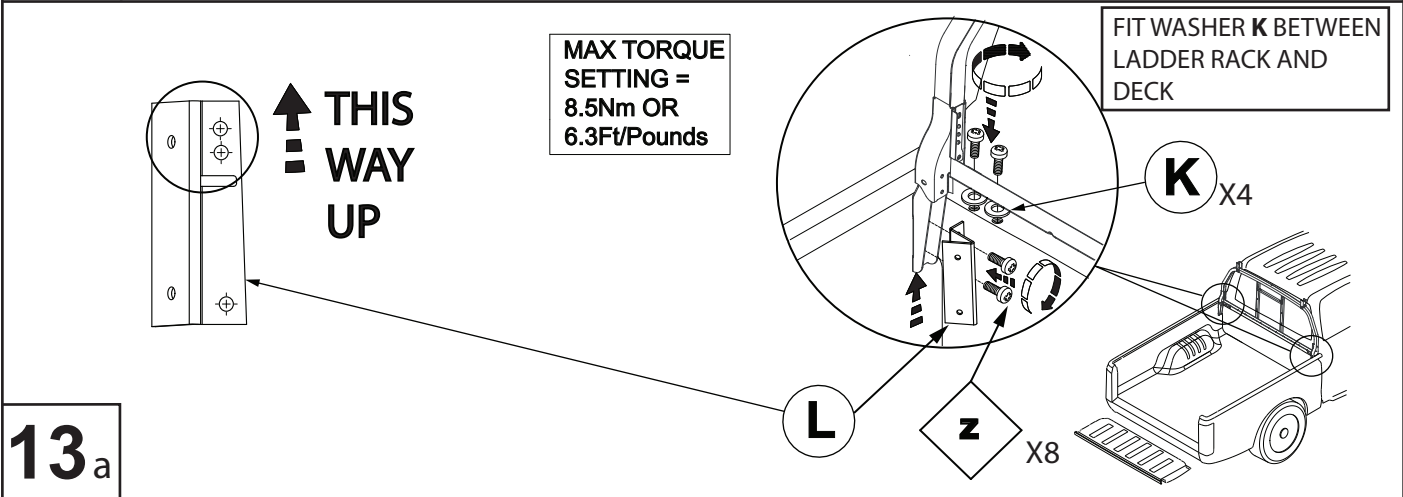

13_a

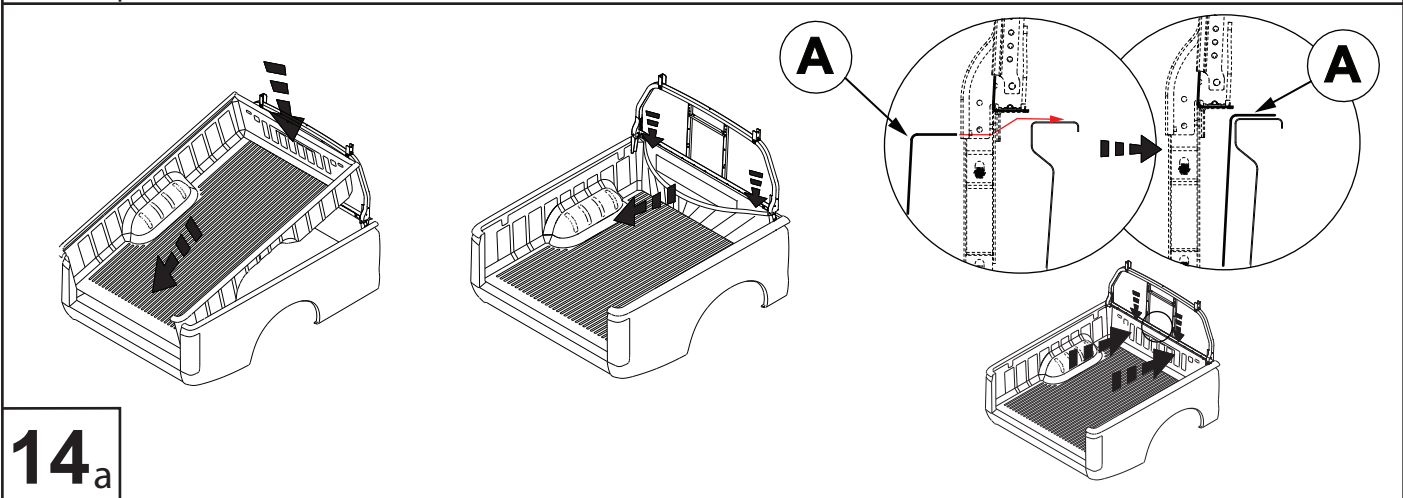

14_a

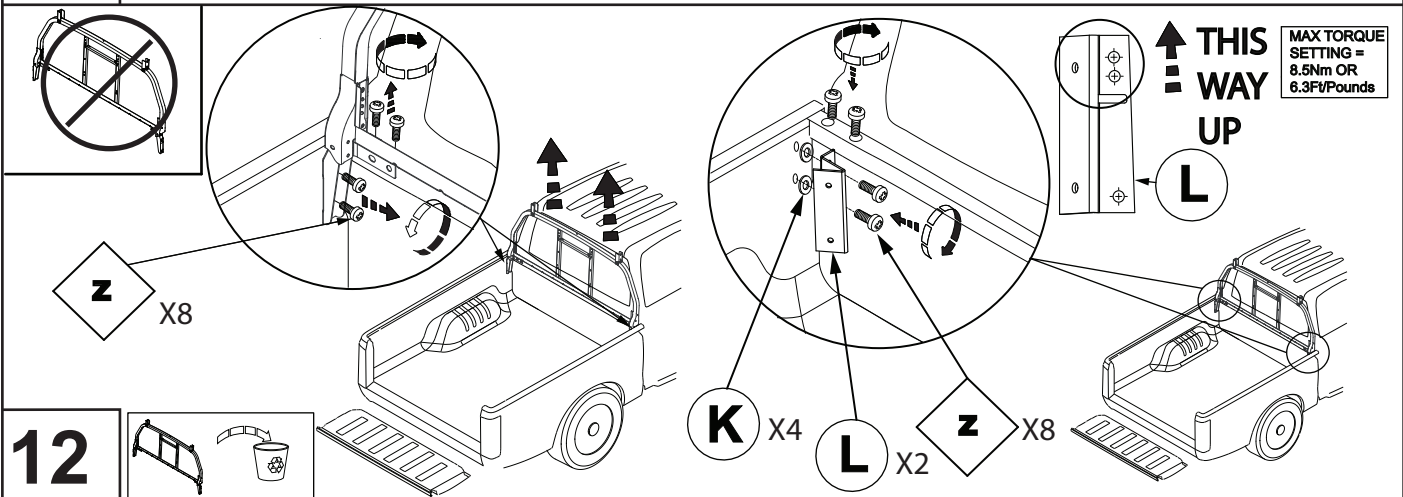

12

| Fitting Kit Number | Manufacturer | Model Type | Year | Stockist | Cab Size | Product | Revision | Date | Page |
|--------------------|--------------|------------|------|-------------|----------|----------|----------|----------|--------|
| K576 | Ford | Ranger | 2011 | General Use | SC | OR Liner | 1 | 24/01/14 | 3 of 4 |

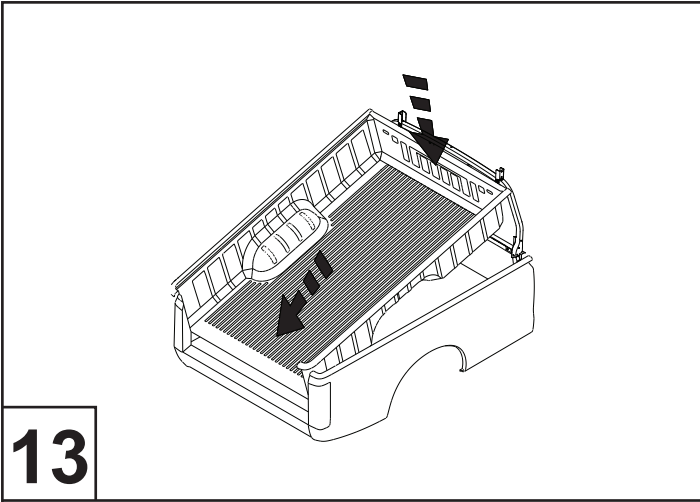

13

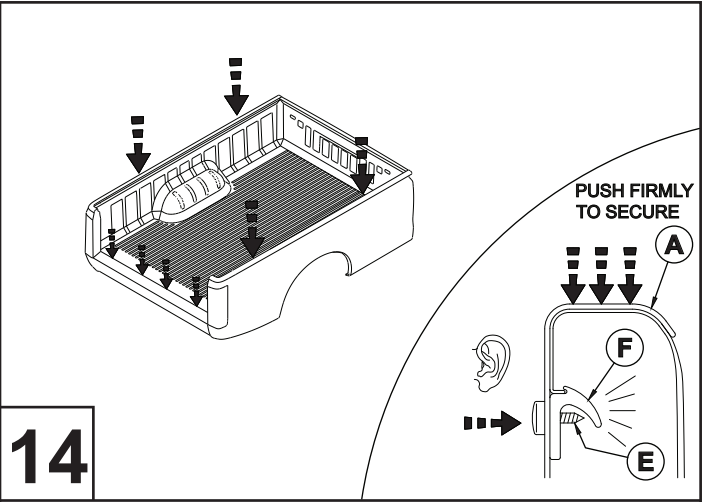

14

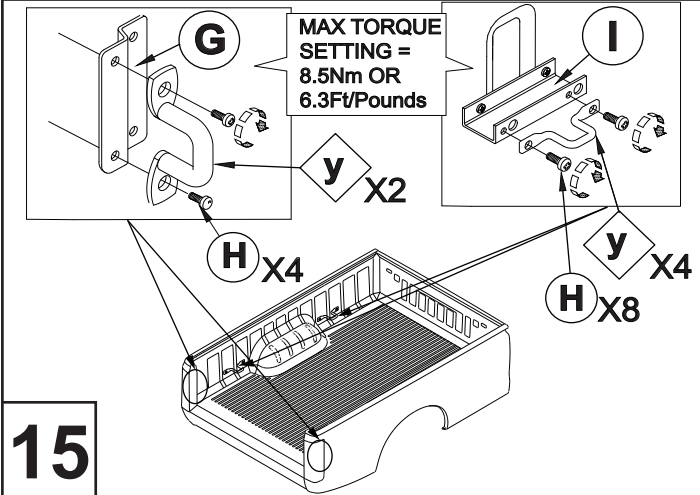

15

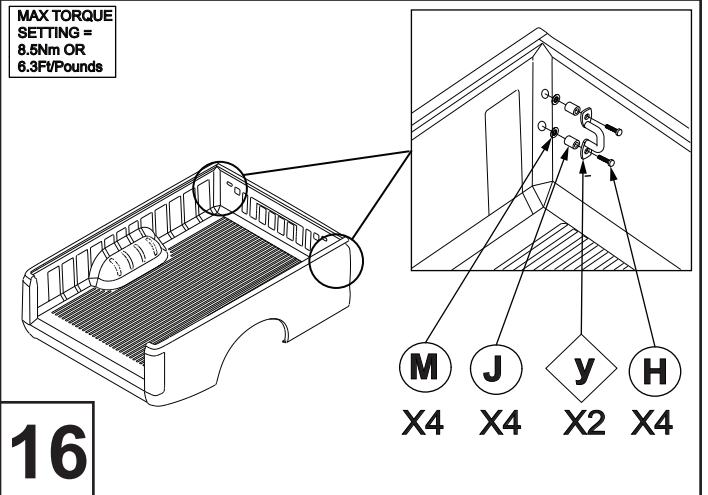

16

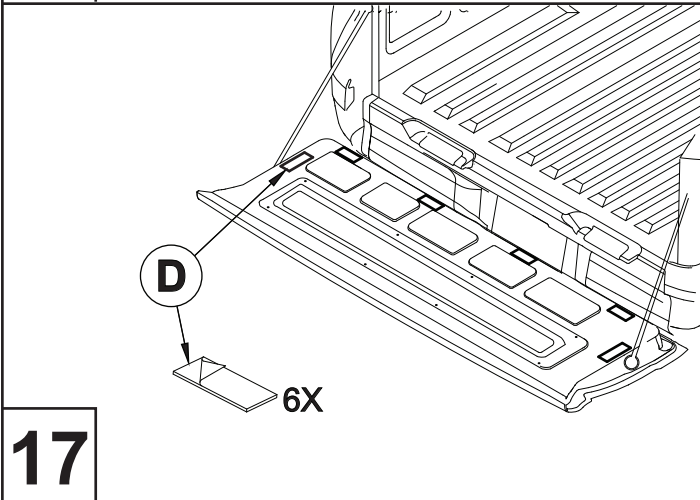

17

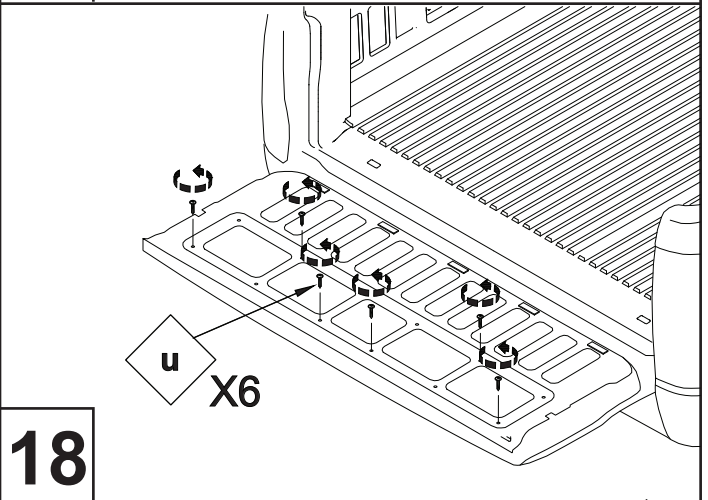

18

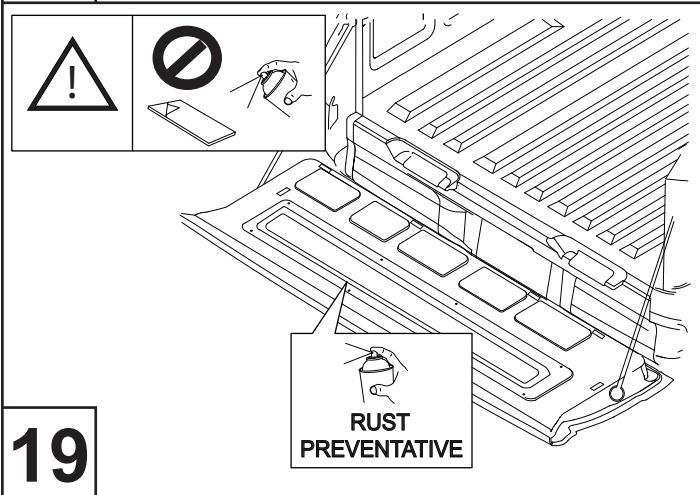

19

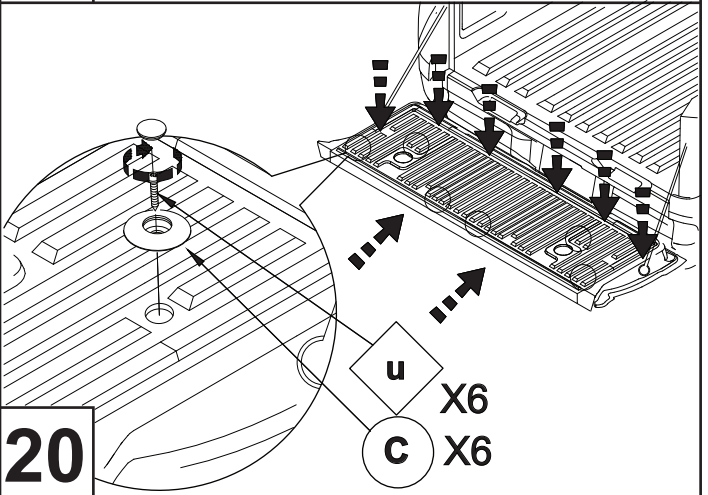

20

| Fitting Kit Number | Manufacturer | Model Type | Year | Stockist | Cab Size | Product | Revision | Date | Page |
|--------------------|--------------|------------|------|-------------|----------|----------|----------|----------|--------|
| K576 | Ford | Ranger | 2011 | General Use | SC | OR Liner | 1 | 20/01/14 | 4 of 4 |