



**OE STYLING BAR FITTING INSTRUCTIONS
FOR VOLKSWAGEN AMAROK 10+**

Part # 10055955

Instruction # 10055950

VOLKSWAGEN OE STYLING BAR FITTING INSTRUCTIONS

Part # 10055955

READ INSTRUCTIONS CAREFULLY BEFORE COMMENCING THIS ACTIVITY.

General Notes

- Read through the fitting instructions before installation of accessory.
- Always install the accessory following the fitting instructions. Failure to do so may cause damage to the vehicle or the accessory and void the warranty.
- Ensure all recyclable discarded vehicle/accessory components and packaging are disposed following local recycling regulations.
- It is always recommended that this accessory is fitted by a qualified Technician.
- Safely store and protect any removed vehicle components.
- Ensure all bare metal surfaces are protected using Automotive Bare Metal Primer and touch-up paint.
- Remove all metal swarf and dust from all vehicle surfaces if surface is used for accessory installation.
- Ensure all fasteners are torqued to the specifications as per instruction.
- Apply any adhesives to the vehicle only when the surface temperature is between 20°C to 40°C.
- Recommended all smooth lids are painted. Failure to paint lid will void the warranty.

General Vehicle and Accessory Warranty Notes and Cautions

- For correct installation and proper operation of the vehicle and accessory we recommend this accessory is fitted by a qualified Technician.
- During the accessory fitment ensure all automotive safety practices and regulations are followed.
- Do not modify the vehicle in any way other than specified in these Accessory Fitting Instructions as this may void the warranty.

Safety Notes

- Check that all work practises comply with safety standards.
- It is advisable to seek assistance from another person when lifting heavy components.
- While using power tools ensure safe procedures are followed.
- Appropriate clothing & PPE must be worn.



VOLKSWAGEN OE STYLING BAR FITTING INSTRUCTIONS













Part # 10055955

READ INSTRUCTIONS CAREFULLY BEFORE COMMENCING THIS ACTIVITY.

Fitment Time : 45 Minutes







Accessory fitting times are provided as a guide only. Accessory fitting times are for the installation of the product only and do not include administration or vehicle processing time.

Tools Required					
No.	Description	Image	No.	Description	Image
1	Drill		2	Loctite 243	
3	Ø11mm Drill Bit Ø12mm Drill Bit		4	Masking Tape	
5	Ø19mm Hole Saw Ø25mm Hole Saw		6	5mm Metric Hex Key	
7	Torque Wrench 5mm Metric Hex Bit		8	Vice Grips	
9	Tectyl 506-WD		10	Utility Knife	
11	13mm Spanner 17mm Spanner		12	25mm Grinding Disc	

VOLKSWAGEN OE STYLING BAR FITTING INSTRUCTIONS

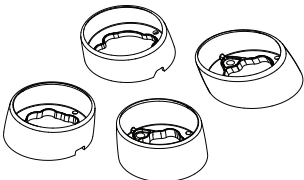
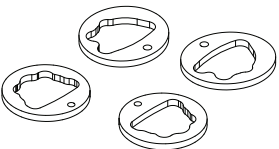
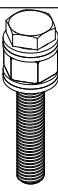
Part # 10055955

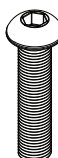

READ INSTRUCTIONS CAREFULLY BEFORE COMMENCING THIS ACTIVITY.

Kit Contents- Hardware				
No.	Item Description	Quantity	Image	Service Part Number
1	Boots	1		10054052
2	Foam Seals	1		
3	M8 Rivnut Installation Bolt	1		10056040
4	M8 Rivnut	6		10056041
5	19mm Plug	4		10055992
6	EPDM M6x22x3mm Washer	4		10056099
7	M8x50mm Bolt	4		10054543

VOLKSWAGEN OE STYLING BAR FITTING INSTRUCTIONS

Part # 10055955

READ INSTRUCTIONS CAREFULLY BEFORE COMMENCING THIS ACTIVITY.

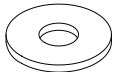
Kit Contents- Hardware				
No.	Item Description	Quantity	Image	Service Part Number
8	M8x10mm Spacer	4		10053165
9	M8x7.5mm Spacer	4		10056063
10	M8x19mm Washer	4		10003717
11	M8x24x2mm Washer	4		10055714

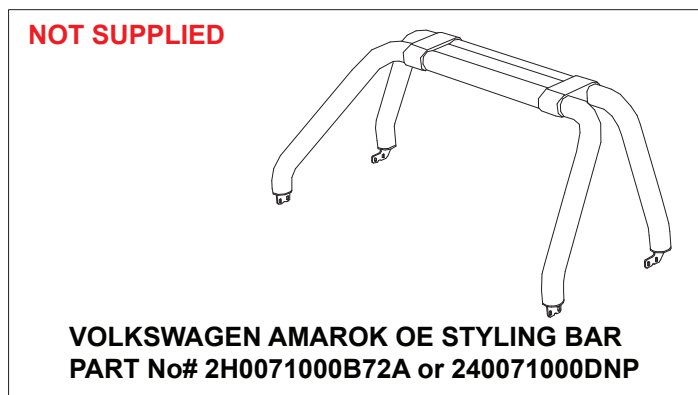

VOLKSWAGEN OE STYLING BAR FITTING INSTRUCTIONS

Part # 10055955

READ INSTRUCTIONS CAREFULLY BEFORE COMMENCING THIS ACTIVITY.

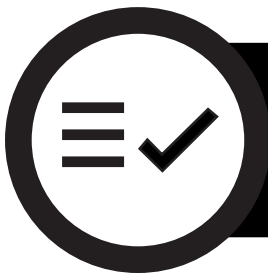

Check that the contents of the Fitting Kit are complete and undamaged.



If any contents of the Fitting Kit are found incomplete or damaged they must be replaced using the specified accessory components.

VOLKSWAGEN OE STYLING BAR FITTING INSTRUCTIONS

Part # 10055955

READ INSTRUCTIONS CAREFULLY BEFORE COMMENCING THIS ACTIVITY.

Step 1 **IMPORTANT!** Take care and drill correct holes

- Place masking tape around pilot holes in aluminium frame to prevent swarf from scratching the aluminium frame.
- Using pilot holes in the aluminium as a position guide, drill 19ϕ hole **through one layer of aluminium only!**
- Note : The pilot drill bit of the hole saw can pass through all layers if required - See next step

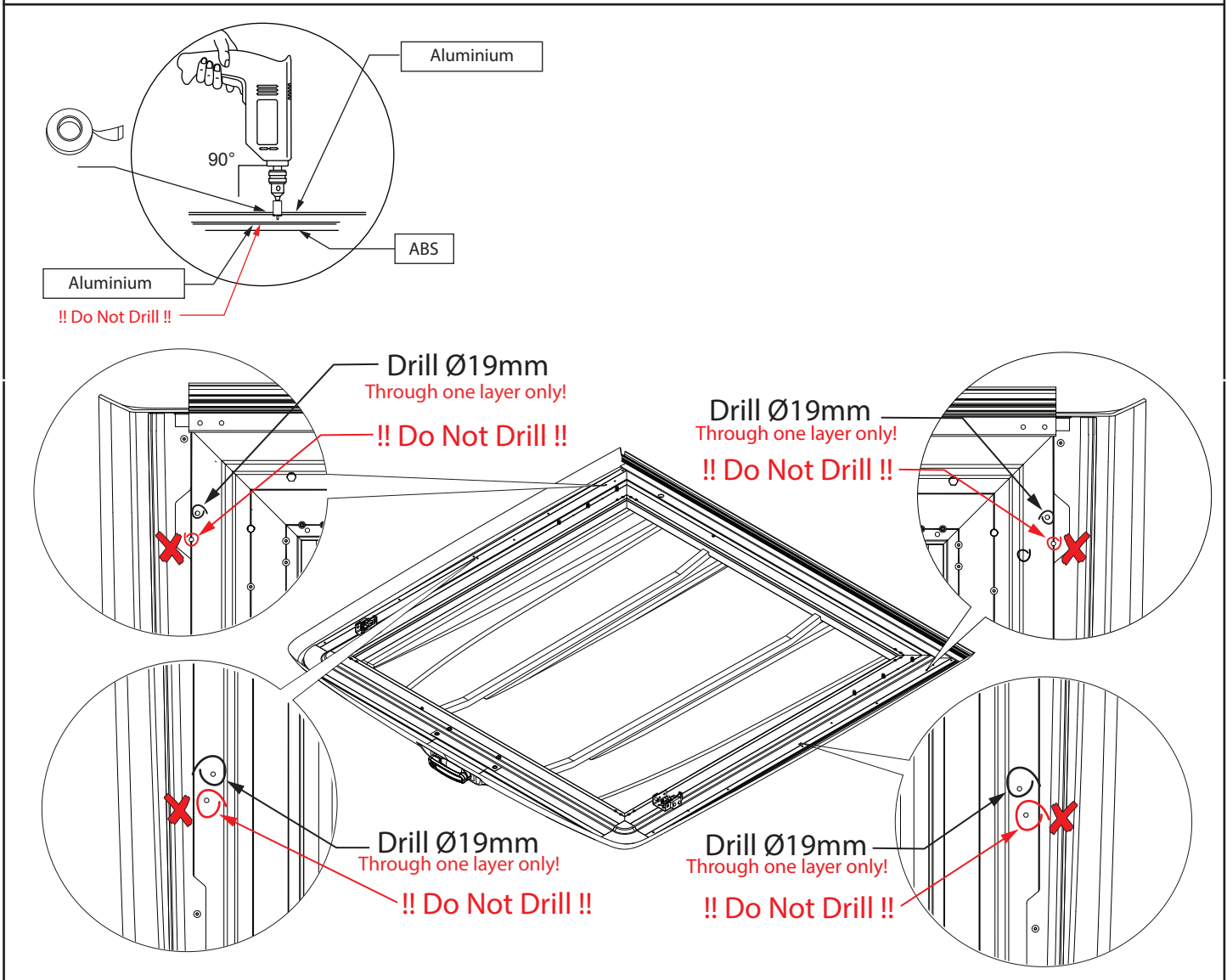

VOLKSWAGEN OE STYLING BAR FITTING INSTRUCTIONS

Part # 10055955

READ INSTRUCTIONS CAREFULLY BEFORE COMMENCING THIS ACTIVITY.

Step 2 **IMPORTANT!** Take care and drill correct holes

- Using pilot holes in the aluminium as a position guide, drill 12 ϕ hole through second layer of aluminium and ABS

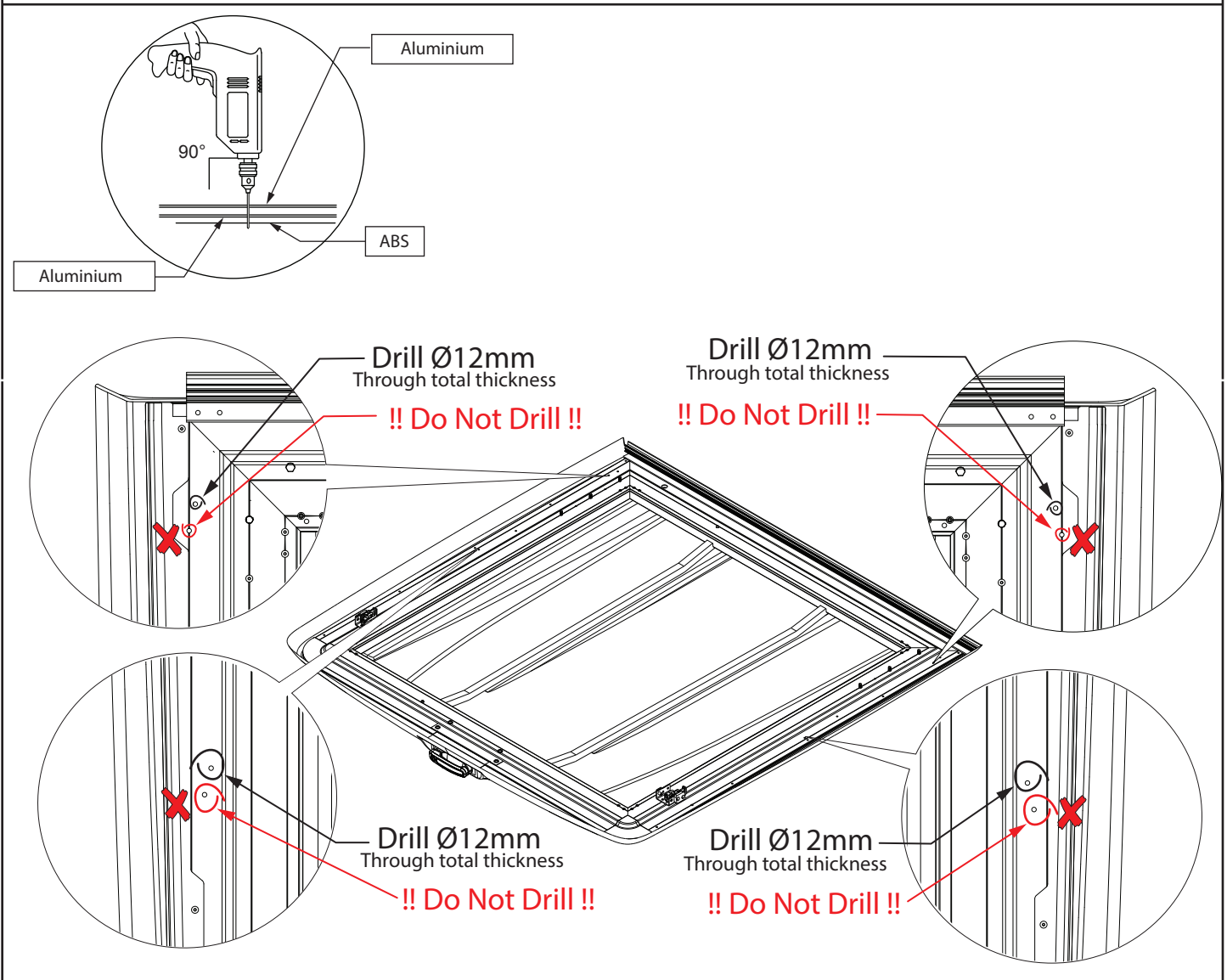

VOLKSWAGEN OE STYLING BAR FITTING INSTRUCTIONS

Part # 10055955

READ INSTRUCTIONS CAREFULLY BEFORE COMMENCING THIS ACTIVITY.

Step 3

- Remove rubber feet and brackets from bar.
- Recycle the fasteners and brackets.
- Keep the rubber feet for later steps.

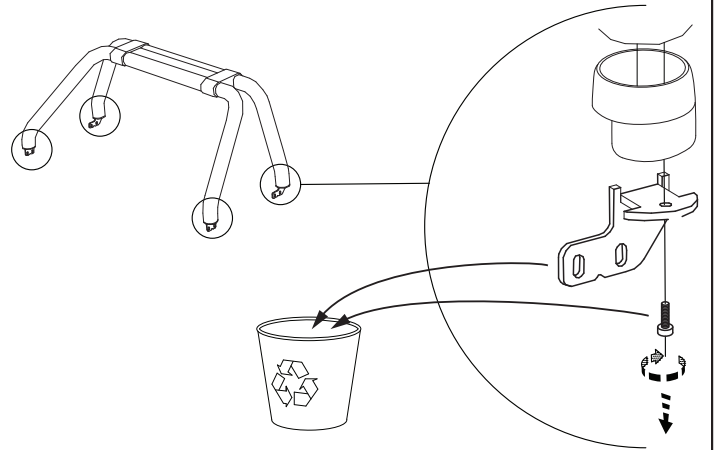

Step 4

- Using vice grips, break off the M6 threaded boss on the feet of the bar.
- Recycle the boss.

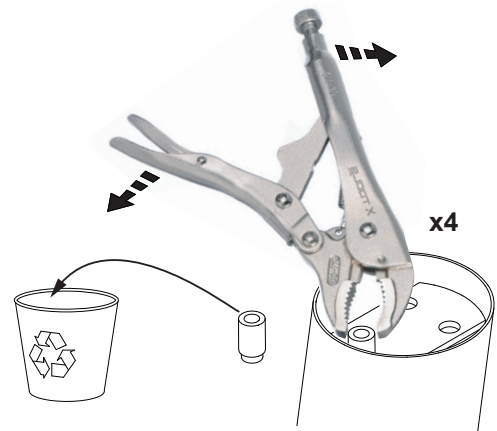

Step 5

- Drill out hole with Ø11mm drill bit

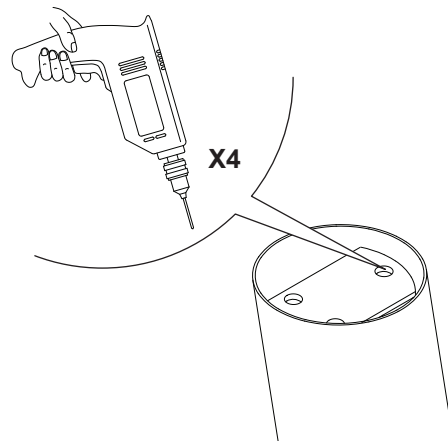

VOLKSWAGEN OE STYLING BAR FITTING INSTRUCTIONS

Part # 10055955

READ INSTRUCTIONS CAREFULLY BEFORE COMMENCING THIS ACTIVITY.

Step 6

- Using a grinding disc remove the the weld from the boss.
- Grind flat.

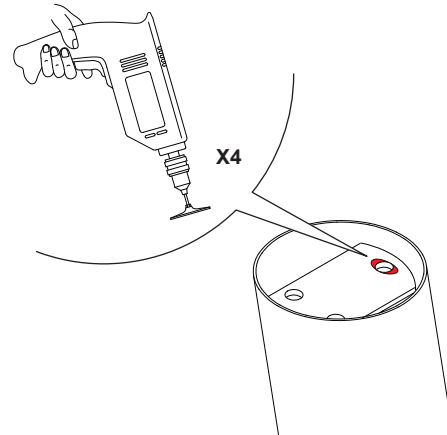

Step 7

- Peel off the backing paper on the boots foam seals (item 2)
- Adhere the foam seals to the bottom of the boots (item 1)
- Ensure the cut out profile lines up with the boot

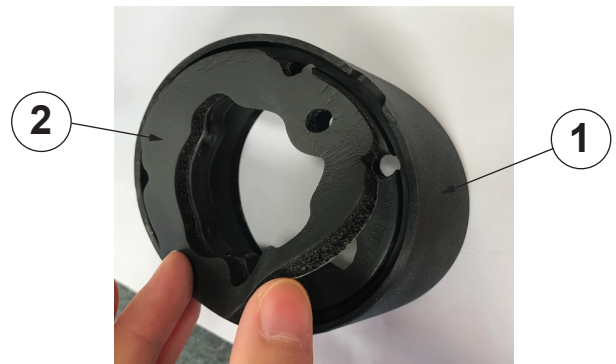

Step 8

- Drill out hole in boots (item 1) with Ø25mm hole saw

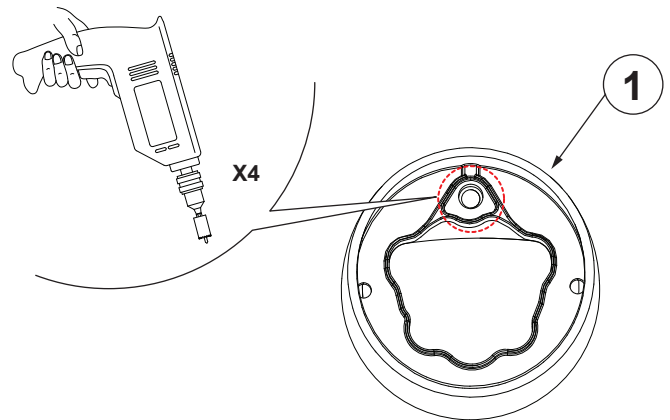

VOLKSWAGEN OE STYLING BAR FITTING INSTRUCTIONS

Part # 10055955

READ INSTRUCTIONS CAREFULLY BEFORE COMMENCING THIS ACTIVITY.

Step 9

- Assemble rivnut installation bolt.

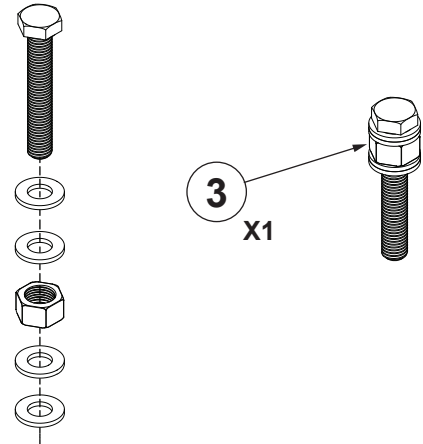

Step 10 - REQUIRED ON BLACK BAR ONLY!

IMPORTANT! CRITICAL STEP!

- Mask bar feet 10mm from edge
- Apply Rust Preventative TECTYL 506-WD on the inside and outside of the bar up to the masking tape.

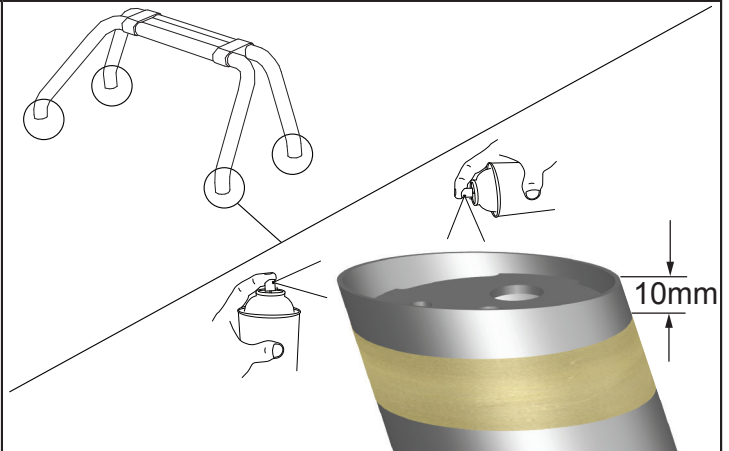

Step 11

- Screw rivnut (item 4) onto the rivnut installation bolt (item 3) all the way.

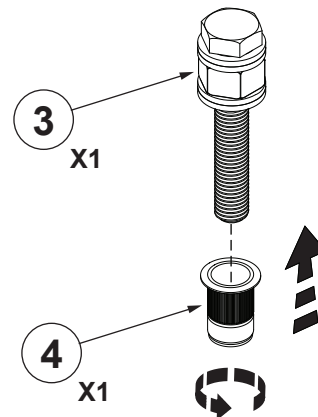

VOLKSWAGEN OE STYLING BAR FITTING INSTRUCTIONS

Part # 10055955

READ INSTRUCTIONS CAREFULLY BEFORE COMMENCING THIS ACTIVITY.

Step 12

- Place rivnut installation bolt into the $\text{\O}11\text{mm}$ hole drilled in the bar.

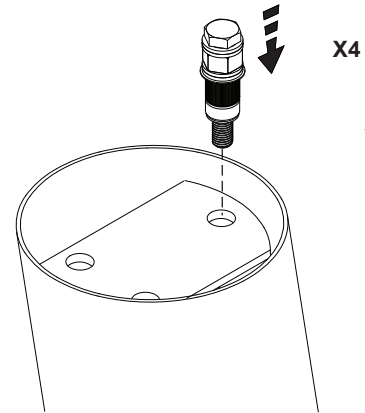

Step 13

- Use a 17mm spanner to hold the M10 nut

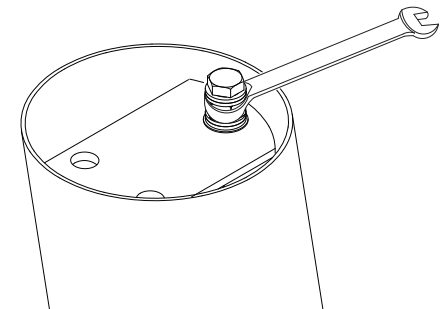

Step 14

- Ensure installation bolt is held firmly into hole.
- Hold the 17mm spanner.
- Use a 13mm spanner to tighten the M8

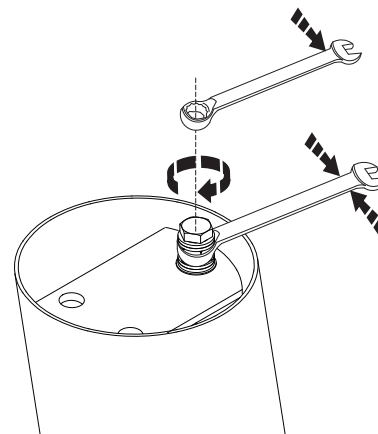

VOLKSWAGEN OE STYLING BAR FITTING INSTRUCTIONS

Part # 10055955

READ INSTRUCTIONS CAREFULLY BEFORE COMMENCING THIS ACTIVITY.

Step 15

- **Unscrew** the hex head bolt and remove the rivnut installation bolt (item 3)

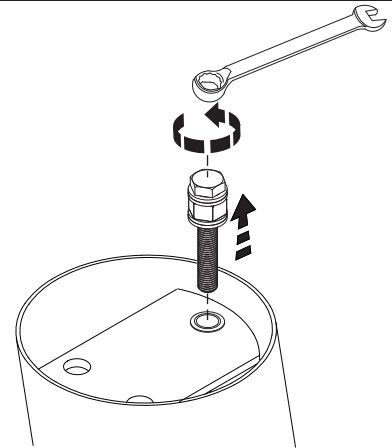

Step 16

IMPORTANT! CRITICAL STEP!

- Inspect rivnut to ensure it is installed correctly.
- If necessary reinsert rivnut installation bolt (item 3) and tighten further
- Repeat steps 9 to 16 for other feet.

Step 17

IMPORTANT! CRITICAL STEP!

- **Apply LOCTITIE 243 (not supplied) to the thread of the rivnut.**
- **DO NOT** allow LOCTITE to touch painted or unpainted lid

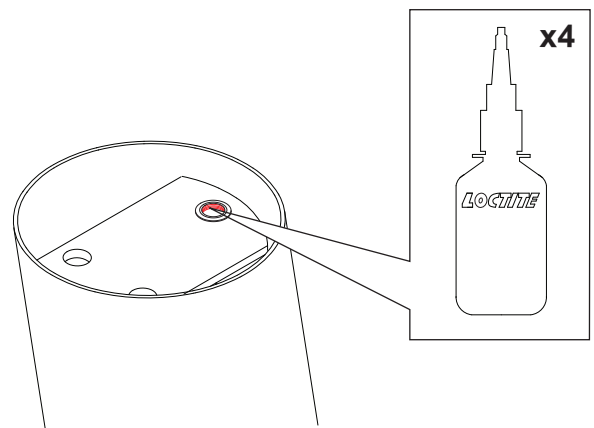

VOLKSWAGEN OE STYLING BAR FITTING INSTRUCTIONS

Part # 10055955

READ INSTRUCTIONS CAREFULLY BEFORE COMMENCING THIS ACTIVITY.

Step 18

- Place boots (item1) onto bar

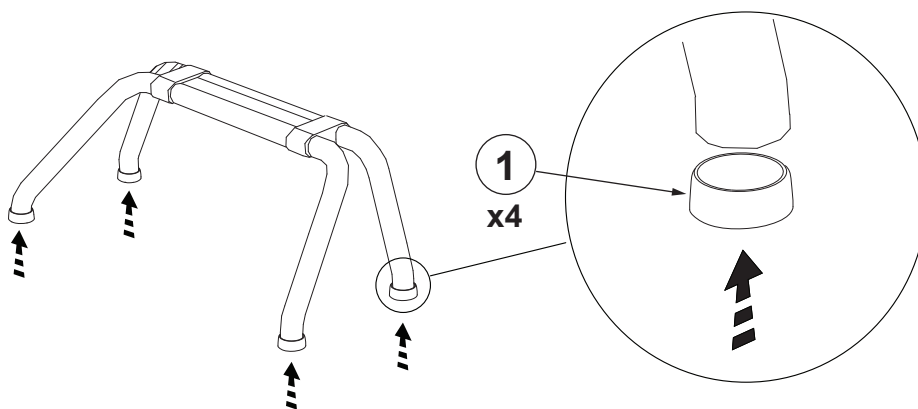

Step 19

- Install fasteners in the order shown

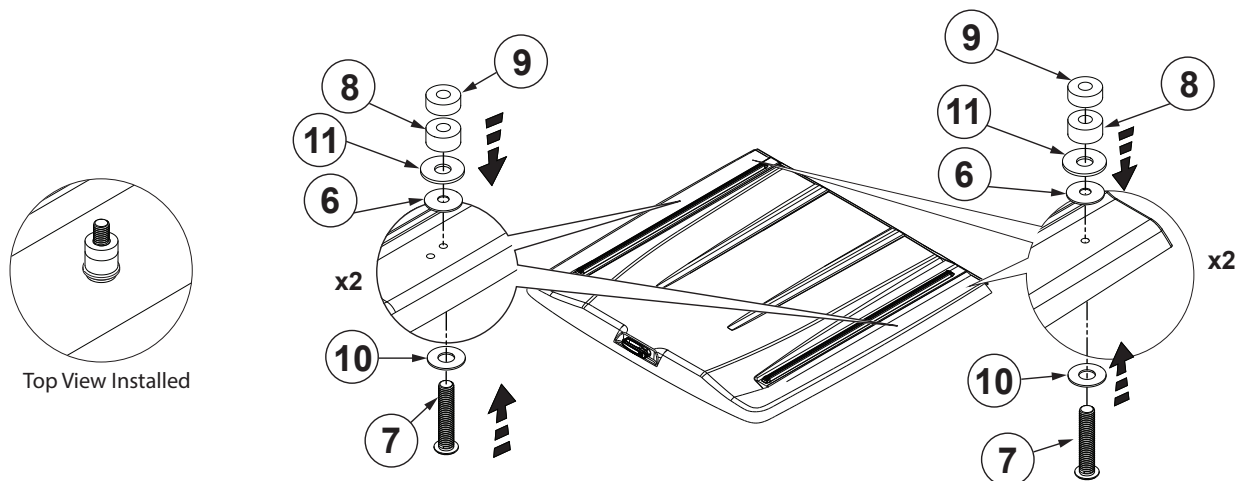

VOLKSWAGEN OE STYLING BAR FITTING INSTRUCTIONS

Part # 10055955

READ INSTRUCTIONS CAREFULLY BEFORE COMMENCING THIS ACTIVITY.

Step 20

- Place bar onto lid

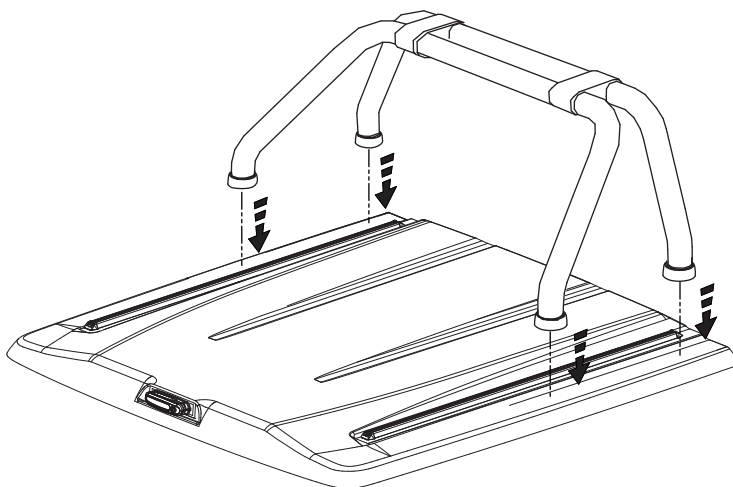

Step 21

- Tighten M8 bolts (item7) using 5mm hex key and torque wrench

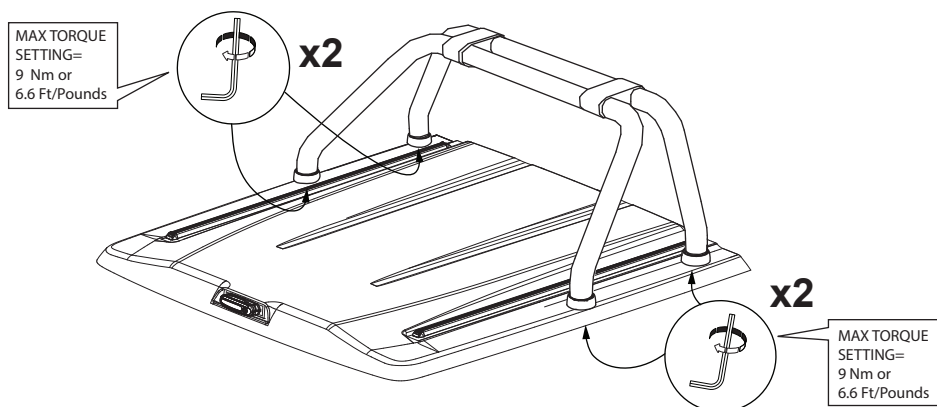

VOLKSWAGEN OE STYLING BAR FITTING INSTRUCTIONS

Part # 10055955

READ INSTRUCTIONS CAREFULLY BEFORE COMMENCING THIS ACTIVITY.

Step 22

- Fix plugs (item 5) to holes

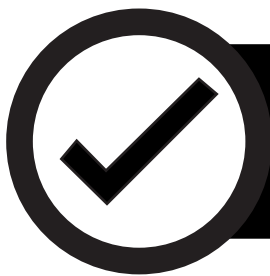
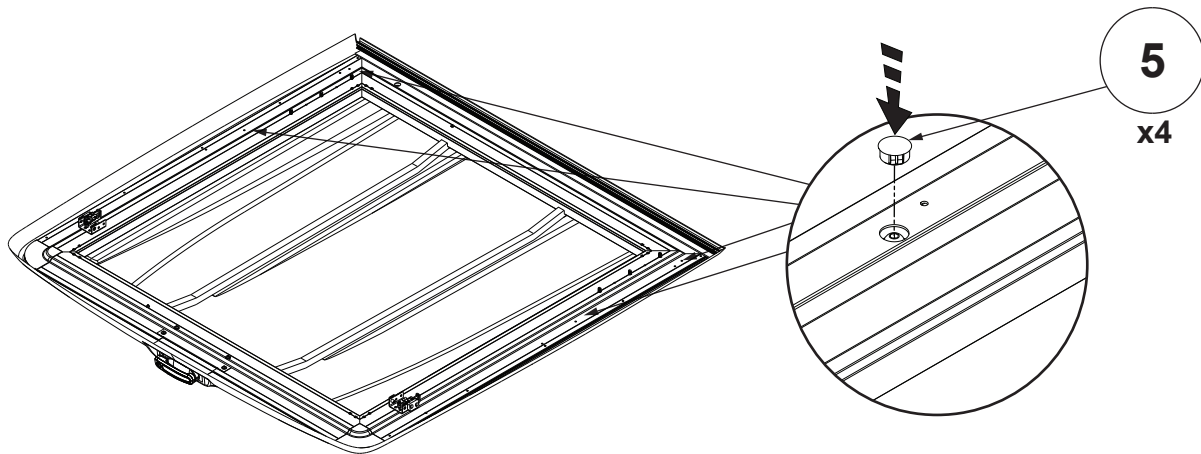

Installation complete. Please place these fitting instructions inside the owners manual wallet.