



INSTALLATION INSTRUCTIONS (K432)  
**SPORTLID FOR TANGO**  
SMOOTH STANDARD  
Ford Ranger D/C, 2011+

### IMPORTANT

- Vehicle bodies and vehicle specific installation can vary, so please read the following instructions as they refer to important information which could affect the quality of the final installation.
- It is strongly advisable that the **SPORTLID** installation is performed by an authorised dealer.
- Screw torques must be adhered to, otherwise the warranty may become void.
- If a **Bedliner** or a **SPORTGUARD** are fitted there may be some additional trimming required.
- Recommended installation by 2 people.

**Use appropriate safety equipment when fitting the *SPORTLID*.**

*Protective eyewear*



*Hearing protection*



### Warranty







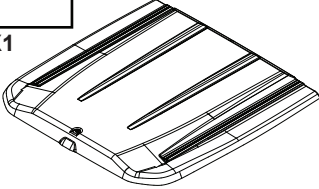

- For warranty information please see your authorised dealer.

### TOOLS REQUIRED

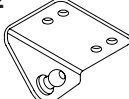
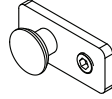

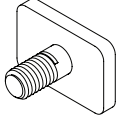
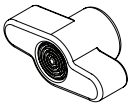

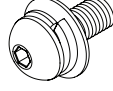
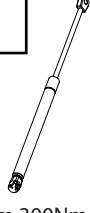
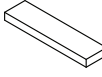

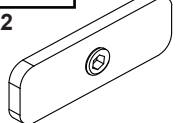

- Hex keys 3, 4, 5, 6mm
- 8,10mm spanners
- Drill and drill bits 14mm
- 150mm ruler
- 1/4 inch Torque wrench 0-10Nm
- 1/4 inch Hex key sockets 3, 4, 5, 6mm
- Silicone caulking gun
- Neutral cure non-acetic silicone
- Side cutters
- Cleaning cloths/rags
- Phillips head screw driver

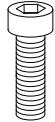
Fitting Kit Number	Manufacturer	Model Type	Year	Stockist	Cab Size	Product	Revision	Date	Page
K432	Ford	Ranger	2011	General Use	DC	SLT	3	06/07/17	1 of 9

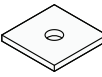
**SPORTLID FOR TANGO PARTS**

<b>A</b> X1 	<b>B</b> X1  L & R Hinges	<b>C</b> X2  Top strut Mount	<b>D</b> X2  Locator	<b>JJ</b> X2  M8 Washer	<b>KK</b> X2  M8 Spring Washer		
<b>E</b> X2  M8 Slide Bolt	<b>F</b> X4  M8 Wing Nut	<b>G</b> X1  Latch Pin	<b>H</b> X12  M6 Button Hex with Washers	<b>I</b> X2  415mm 300Nm	<b>J</b> X2  60x15mm Foam Blocks	<b>K</b> X1  Sportlid Badge	<b>LL</b> X2  Safety Stop

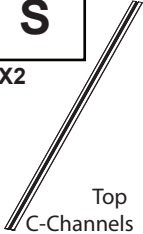
**C CHANNEL PARTS**

<b>L</b> X4  M5x30mm Socket Hex	<b>M</b> X6  M5x22mm Socket Hex	<b>N</b> X10  M5x1.6mm Nylon Washer	<b>O</b> X10  30x30mm Channel Seal	<b>P</b> X6  8mm Spacer	<b>Q</b> X4  M5 Dome Nut	<b>R</b> X4  M5 Spring Washer	<b>S</b> X2  Top C-Channels	<b>CC</b> X4  9mm Spacer ID Ring	<b>DD</b> X4  M10x1.6mm SS Washer
---	---	---	--	---	--	---	--	---	---

**SPORTLID FOR TANGO**  
Can be fitted with the Ford OEM Sportbar.

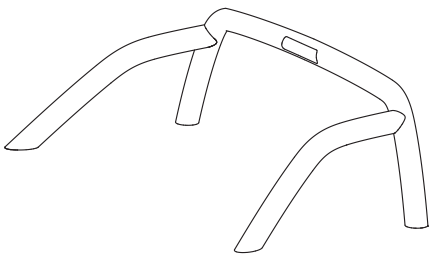

After step 7 see fitting instructions K314.  
Once Sportbar is fitted proceed with step 20.

**SPORTLID FOR TANGO**  
Can be fitted with the Proform **SPORTBAR**.

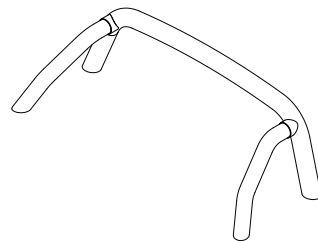

See steps 11 to 19 for fitting instructions.

**1**

Fit Ford Ranger **TANGO**.

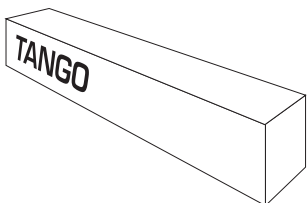

- See fitting kit K439 to fit, supplied in **TANGO** box.
- If a **BEDLINER** or **SPORTGUARD** is pre-fitted please remove before fitment begins.
- When refitting **BEDLINER** or **SPORTGUARD** refer to **TANGO** fitting kit K439 before refitment, additional trimming may be needed.

Fitting Kit Number	Manufacturer	Model Type	Year	Stockist	Cab Size	Product	Revision	Date	Page
K432	Ford	Ranger	2011	General Use	DC	SLT	3	06/07/17	2 of 9

# After paint process is complete continue with Step 2

**2**

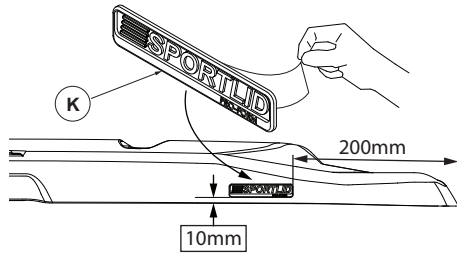

**Step 1**

Apply Non-Acetic Silicone to pre-drilled holes to prevent water penetration.

Fill up the empty space with silicone.

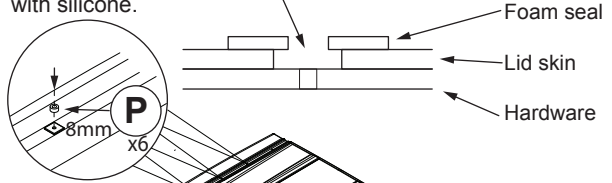

**3**

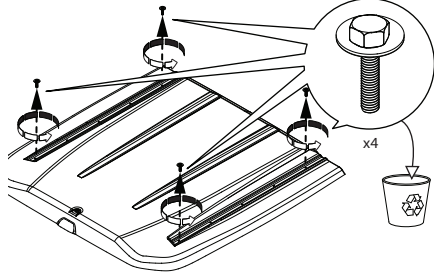

**Step 2**

Use 9mm spacer on each end of the channel, use 8mm spacer in the middle. Repeat on the otherside

**Step 3**

Place 2 x M10 SS washers over the 9mm spacer on each side, in the circled area only.

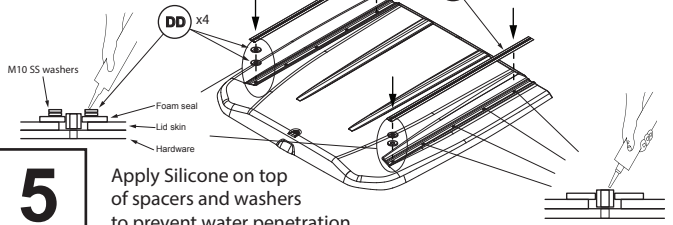

**4**

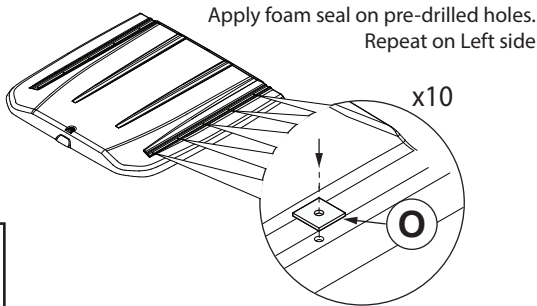

**5**

Apply Silicone on top of spacers and washers to prevent water penetration.

**6**

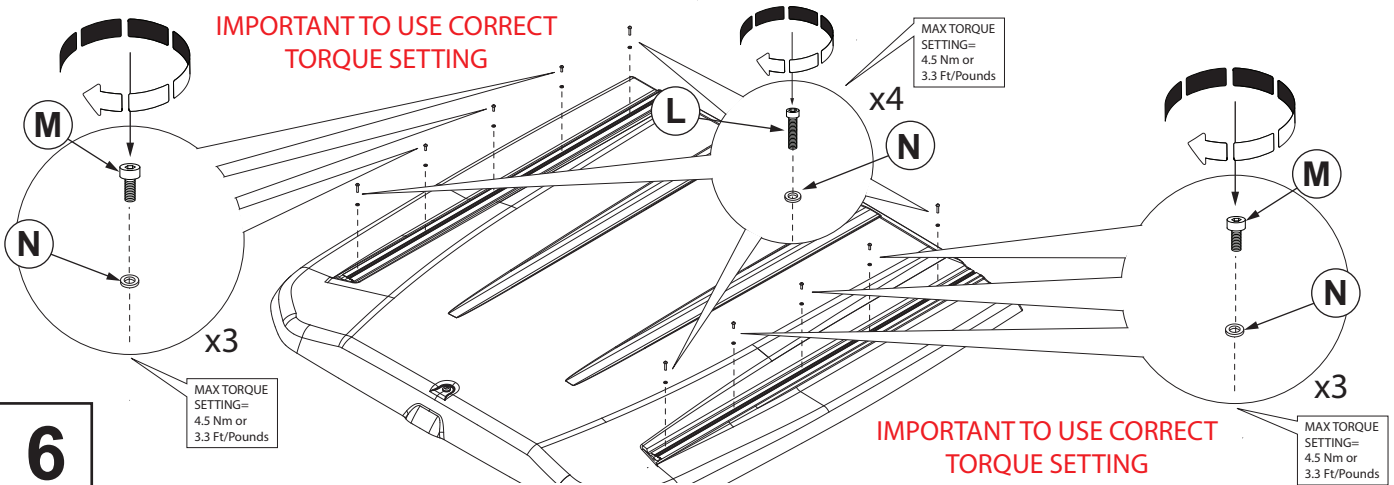

**7**

Note: Using a 8mm spanner, lightly hand tight. Tighten until spring washer is compressed. DO NOT OVER TIGHTEN AS THIS WILL CAUSE DEFORMATION IN THE FRAME.

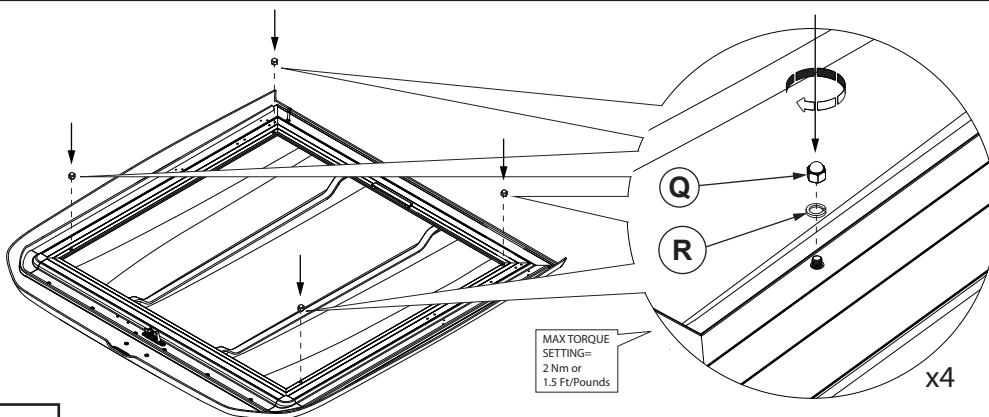

Fitting Kit Number	Manufacturer	Model Type	Year	Stockist	Cab Size	Product	Revision	Date	Page
K432	Ford	Ranger	2011	General Use	DC	SLT	3	06/07/17	3 of 11

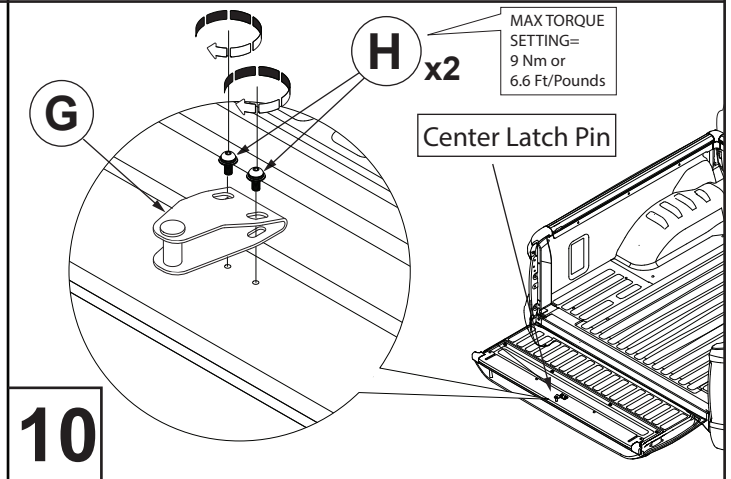
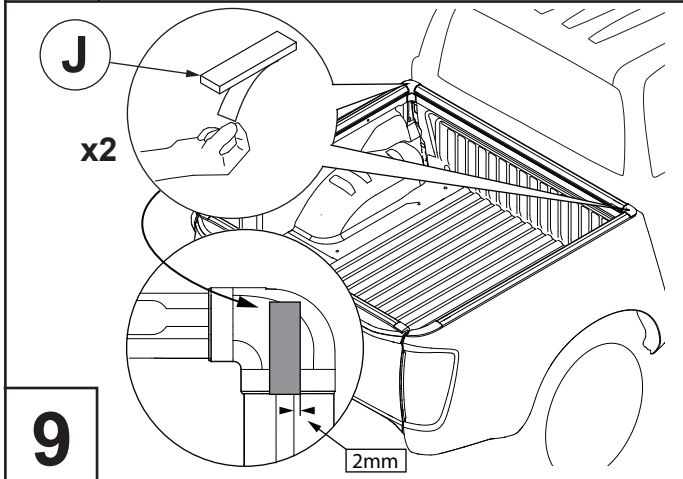
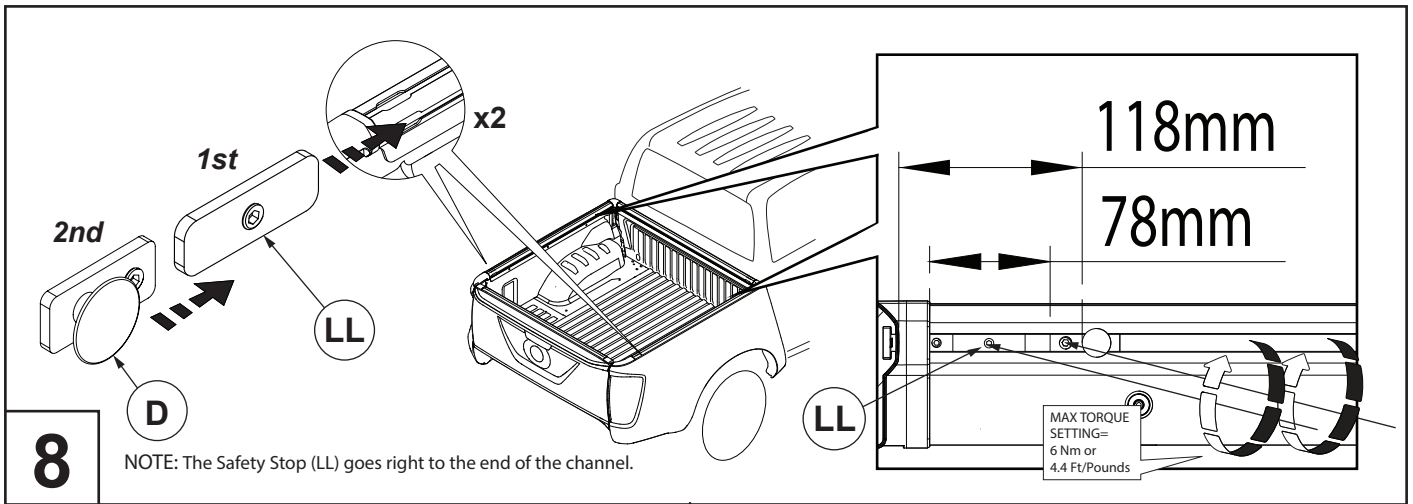

See fitting kit K314 when OE Sportbar is being fitted.

## FITTING PROFORM SPORTBAR

SEE STEPS 11 TO 19

### IMPORTANT to take care and drill correct holes

- Skip to STEP 20 when no **SPORTBAR** is being fitted.
- See fitting kit K310 to assemble **PROFORM SPORTBAR**, follow assembly instructions till step 3 then refer to below steps 12 to 19.

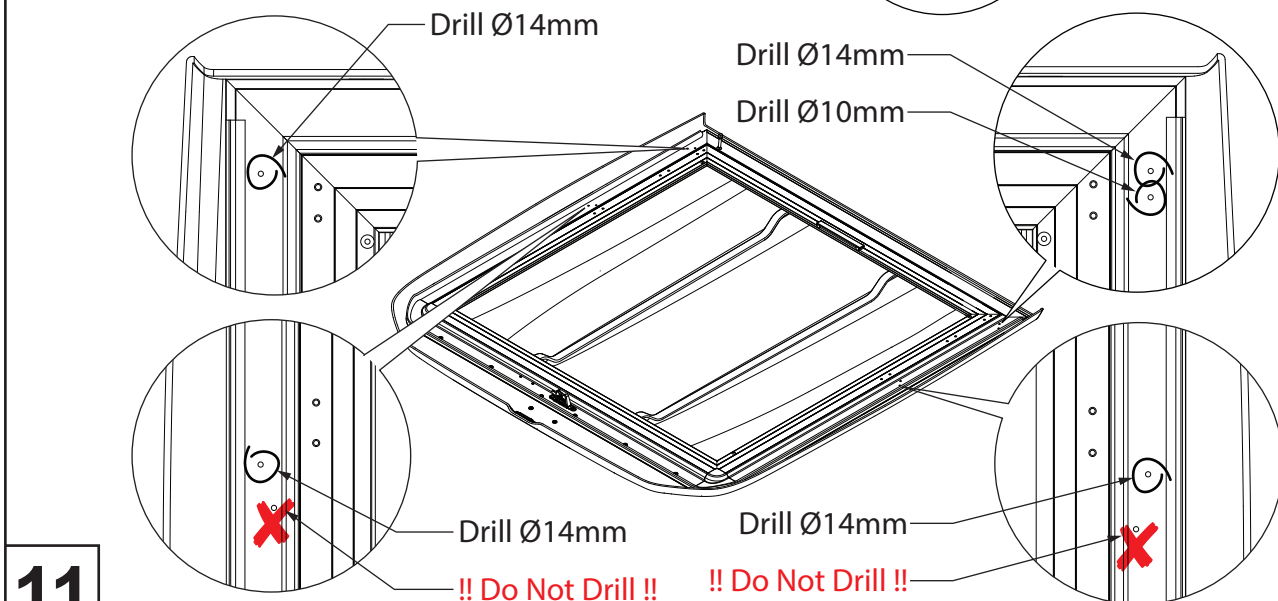
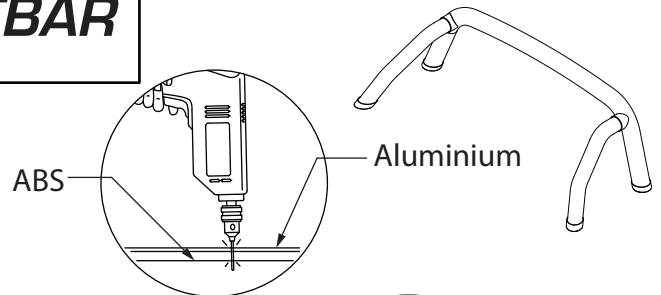

Fitting Kit Number	Manufacturer	Model Type	Year	Stockist	Cab Size	Product	Revision	Date	Page
K432	Ford	Ranger	2011	General Use	DC	SLT	3	06/07/17	4 of 9

Refer to fitting kit K310 for parts.

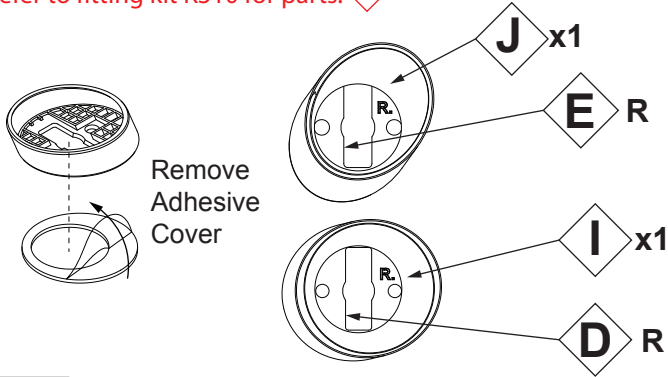

Remove Adhesive Cover

Position seals central with holes and slots exposed.  
**REPEAT FOR LEFT SIDE.**

**12**

Refer to fitting kit K310 for parts.

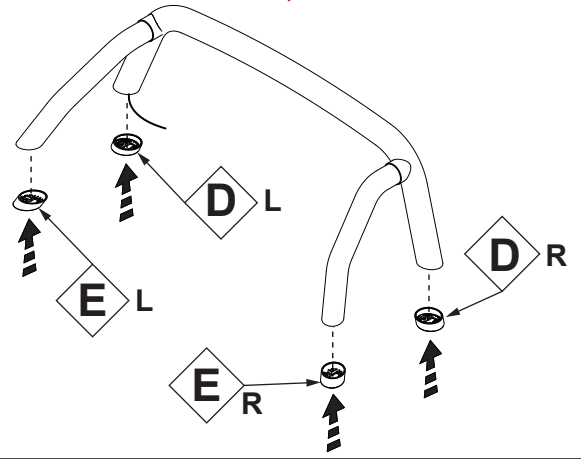

**13**

**IMPORTANT!!!**  
APPLY NON-ACETIC SILICONE TO BOLT HOLE BEFORE AND AFTER FIT WITH SPACERS TO PREVENT WATER PENETRATION.



ENSURE GOOD COVERAGE SO THAT THE SILICONE WILL SEAL THE THREAD.

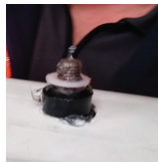

Top View Installed

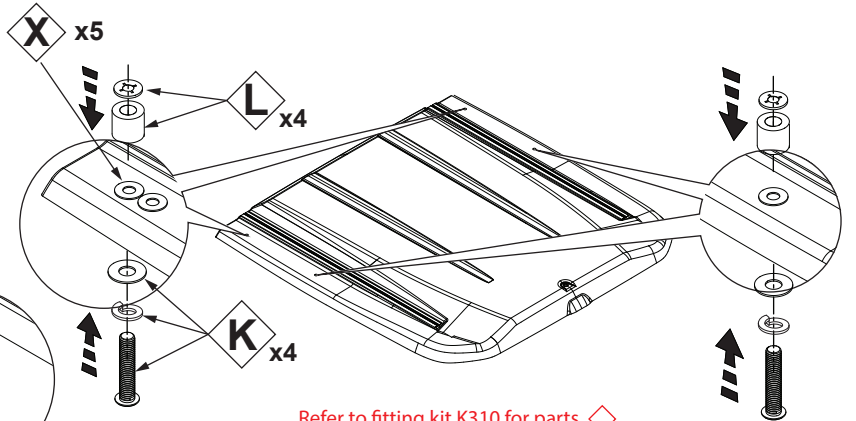

Refer to fitting kit K310 for parts.

**14**

Loosely bolt **SPORTBAR** to the **SPORTLID**.

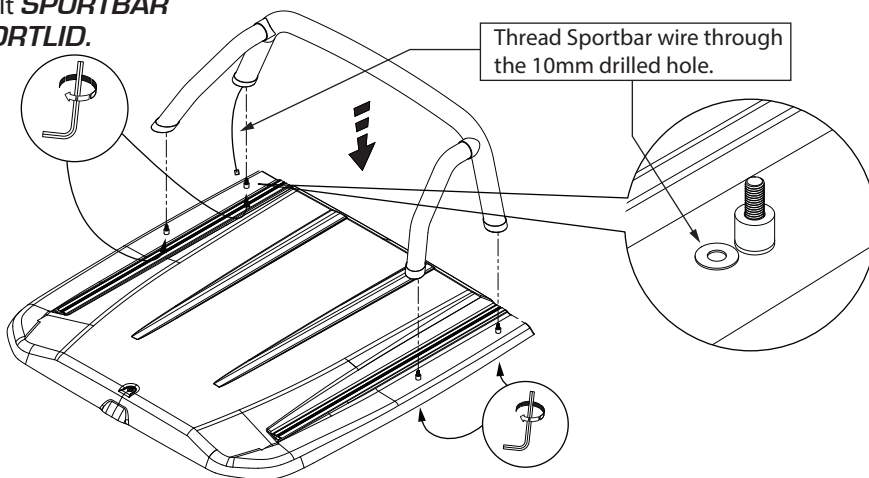

Thread Sportbar wire through the 10mm drilled hole.

Applying silicone after wire is in place.

**15**

Follow fitting instruction steps 18 to 21 of K310 to install Proform **SPORTBAR** wiring harness.

**16**

Follow fitting instruction steps 7-12 of K310 to install High stop cover.

**17**

Clip small connector that comes with the **SPORTBAR** onto the terminals after the **SPORTBAR** is installed.

**MAKE SURE TO MATCH WIRE COLOURS TO THE CONNECTION ON THE PROFORM **SPORTBAR** WIRING HARNESS.**

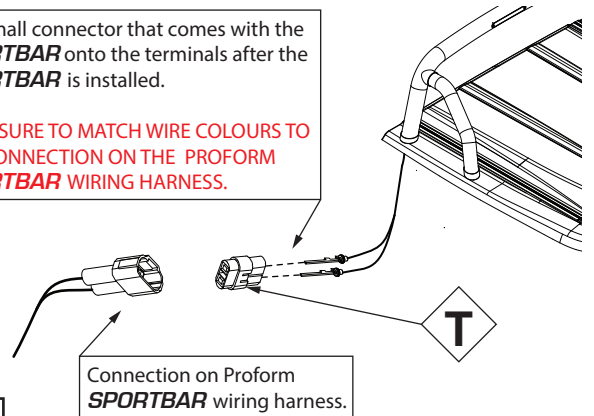

Connection on Proform **SPORTBAR** wiring harness.

**18**

Refer to fitting kit K310 for parts.

Fitting Kit Number	Manufacturer	Model Type	Year	Stockist	Cab Size	Product	Revision	Date	Page
K432	Ford	Ranger	2011	General Use	DC	SLT	3	06/07/17	5 of 9

Feed excess **SPORTBAR** wire back up into the **SPORTBAR** then tighten 4 x bolts.

MAX TORQUE SETTING= 9 Nm or 6.6 Ft/Pounds

MAX TORQUE SETTING= 9 Nm or 6.6 Ft/Pounds

19

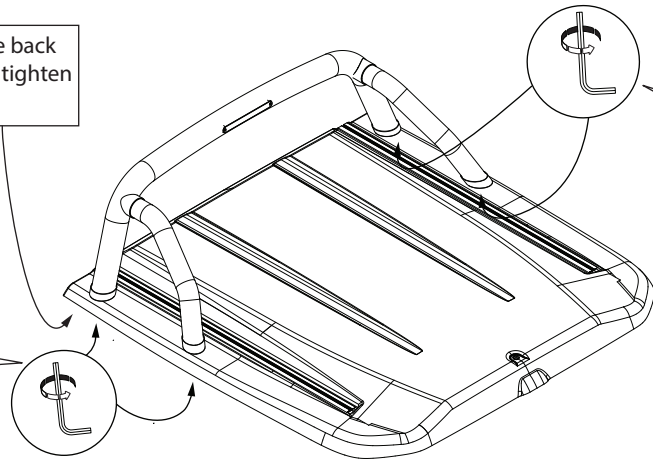

20

MAX TORQUE SETTING= 6 Nm or 4.4 Ft/Pounds

Use these holes

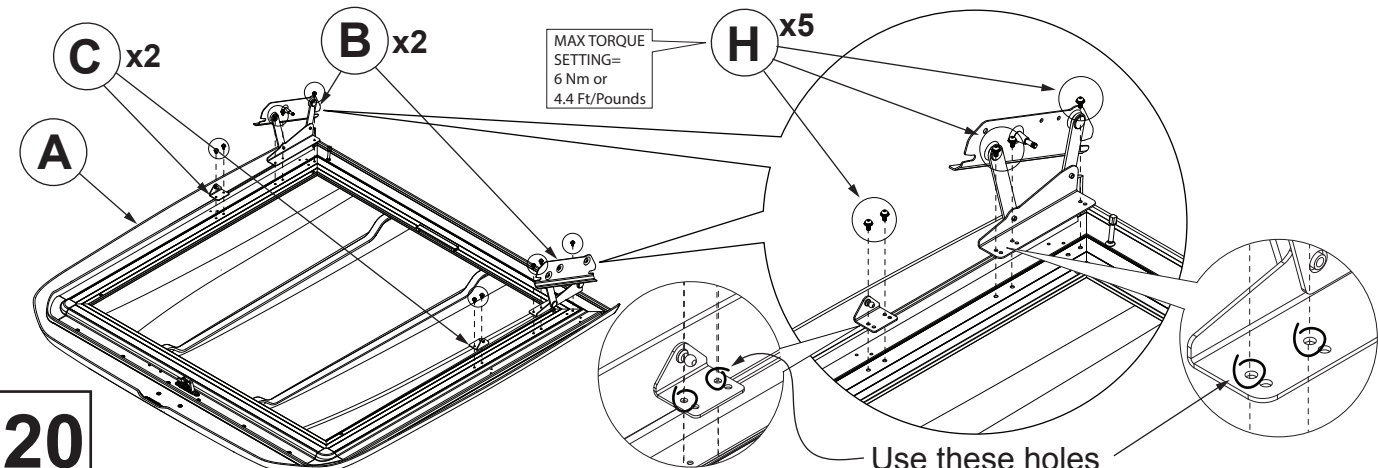

21

x2

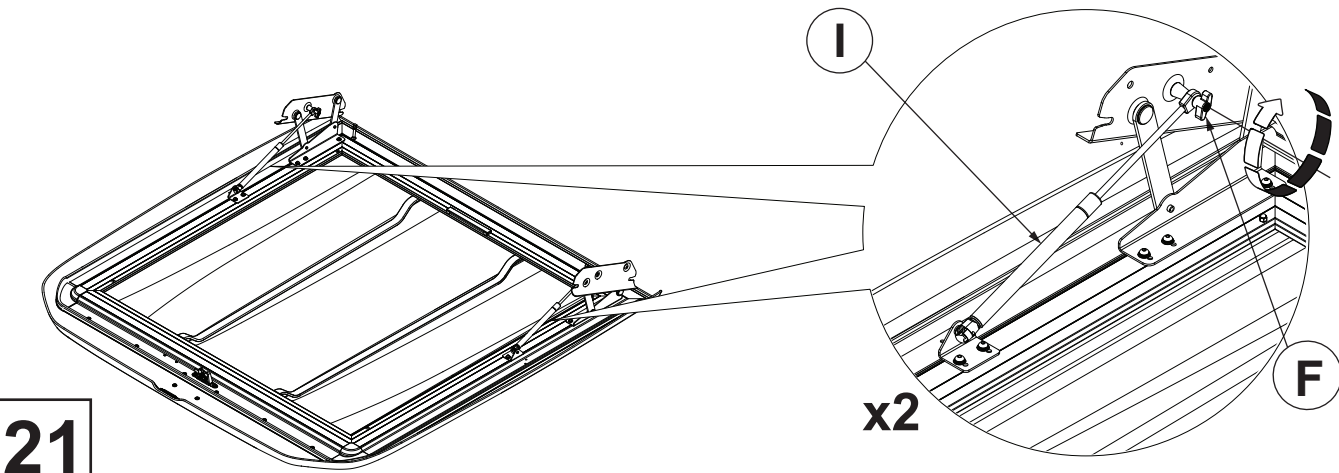

22

Ensure the **SPORTLID** is pushed hard forward against the location lug.

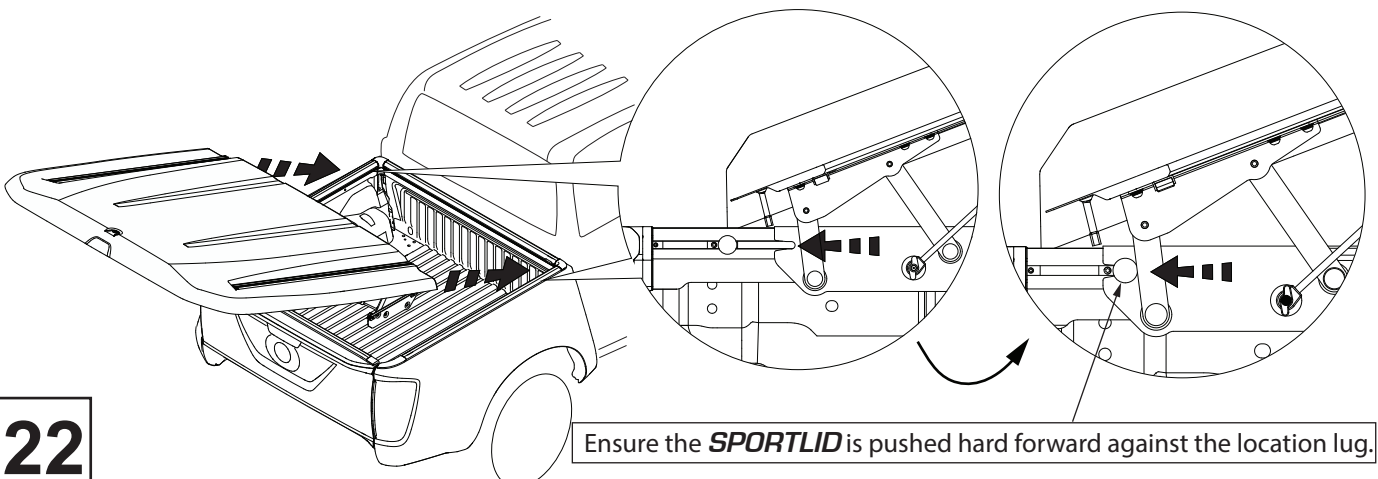

Fitting Kit Number	Manufacturer	Model Type	Year	Stockist	Cab Size	Product	Revision	Date	Page
K432	Ford	Ranger	2011	General Use	DC	SLT	3	06/07/17	6 of 9

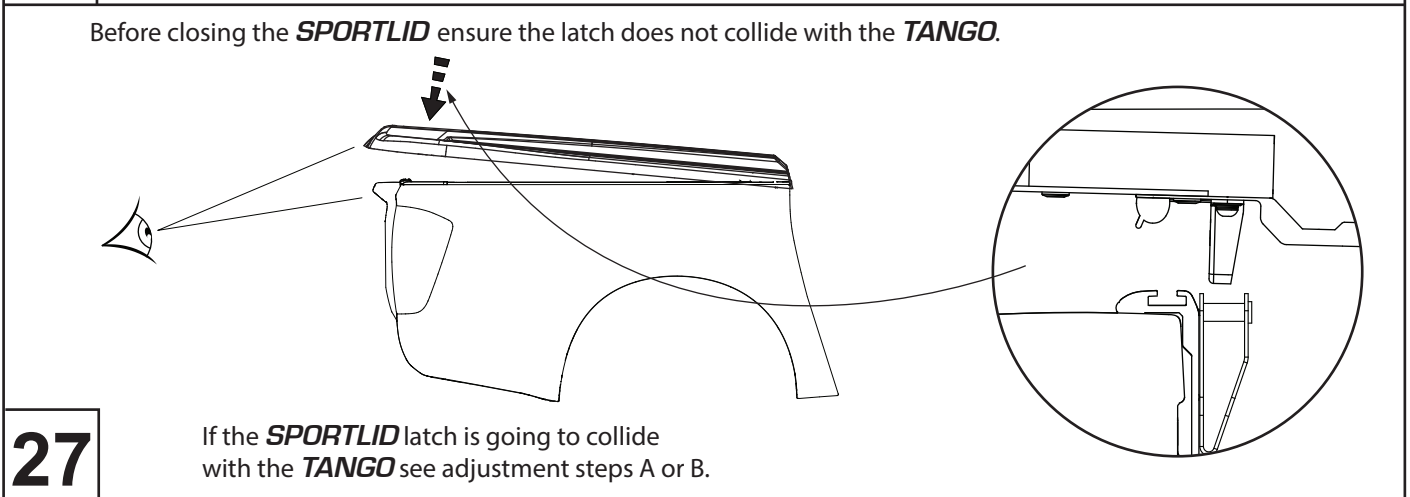
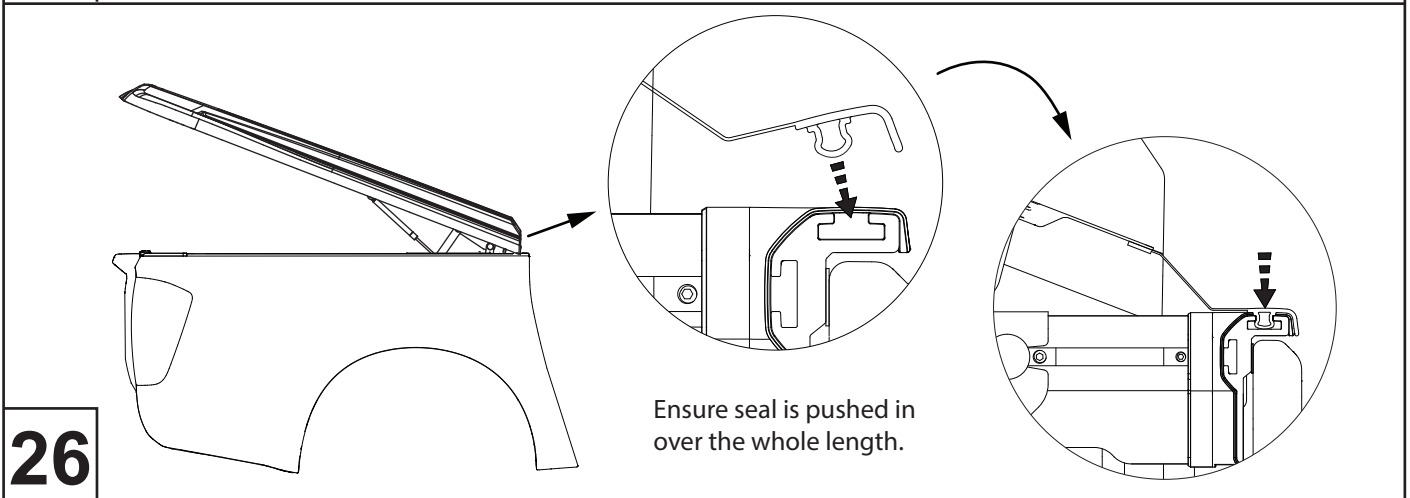
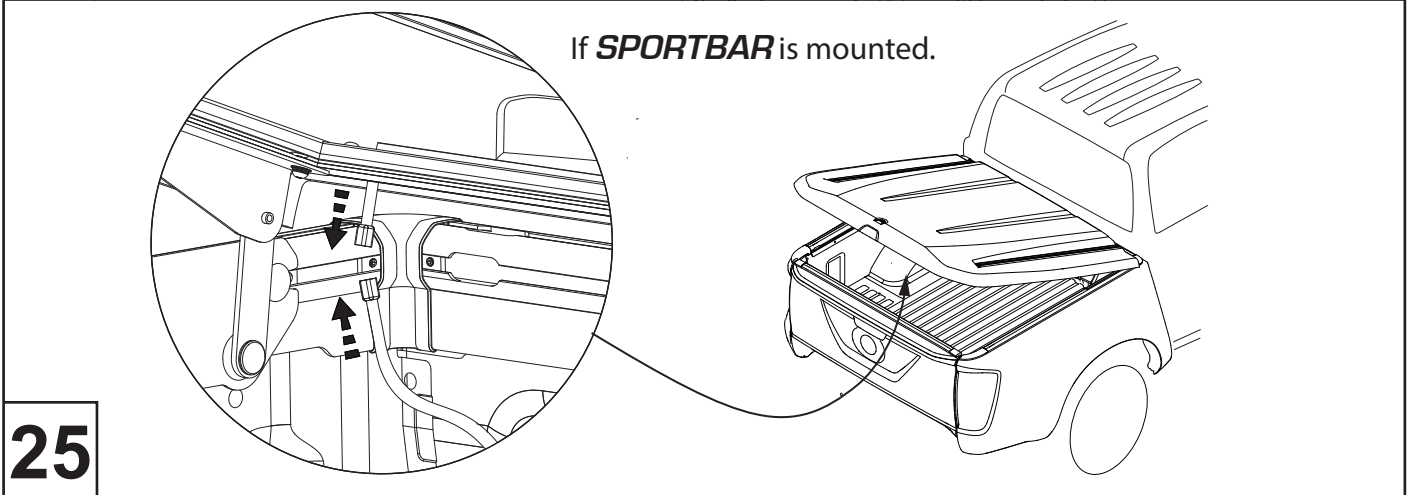
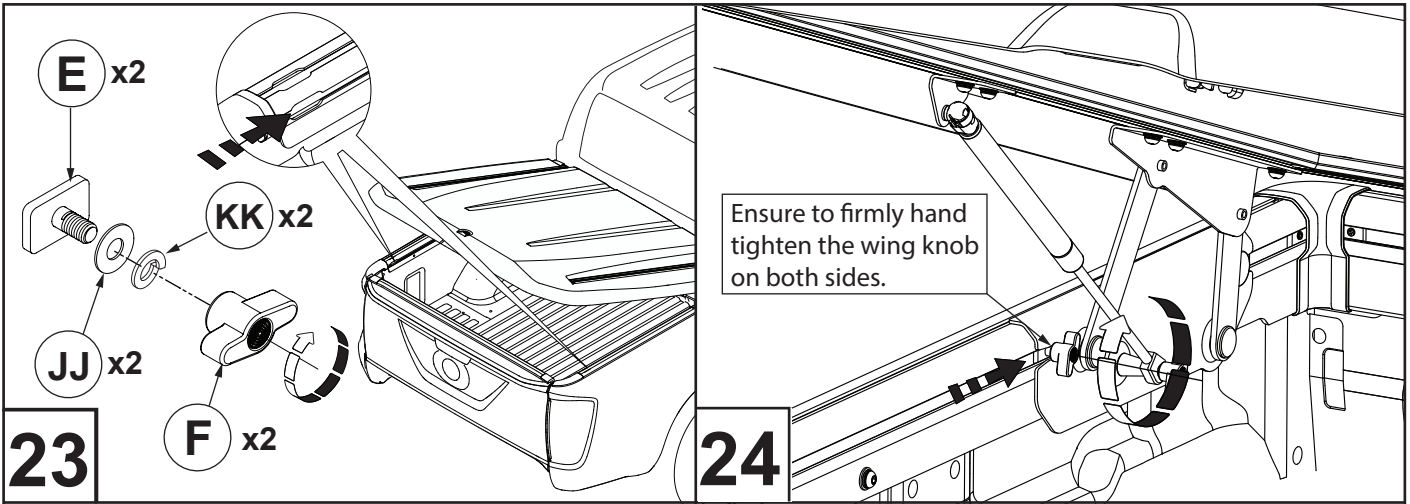

Fitting Kit Number	Manufacturer	Model Type	Year	Stockist	Cab Size	Product	Revision	Date	Page
K432	Ford	Ranger	2011	General Use	DC	SLT	3	06/07/17	7 of 9

## SPORTLID ADJUSTMENT SECTION

### ADJUST BACKWARD AND FORWARD

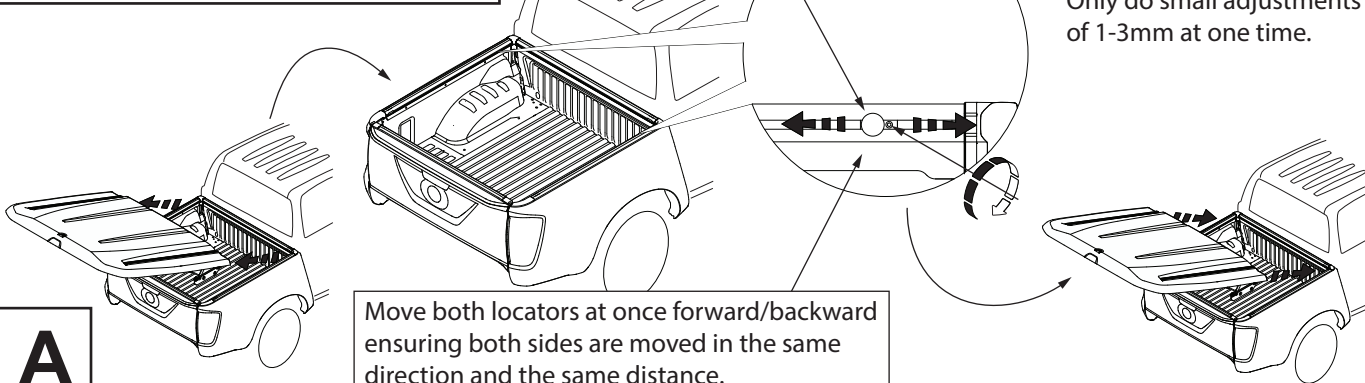

Tip:  
Only do small adjustments  
of 1-3mm at one time.

**A**

Move both locators at once forward/backward ensuring both sides are moved in the same direction and the same distance.

### LATCH ADJUSTMENT

Only use this adjustment if step A did not solve the problem.

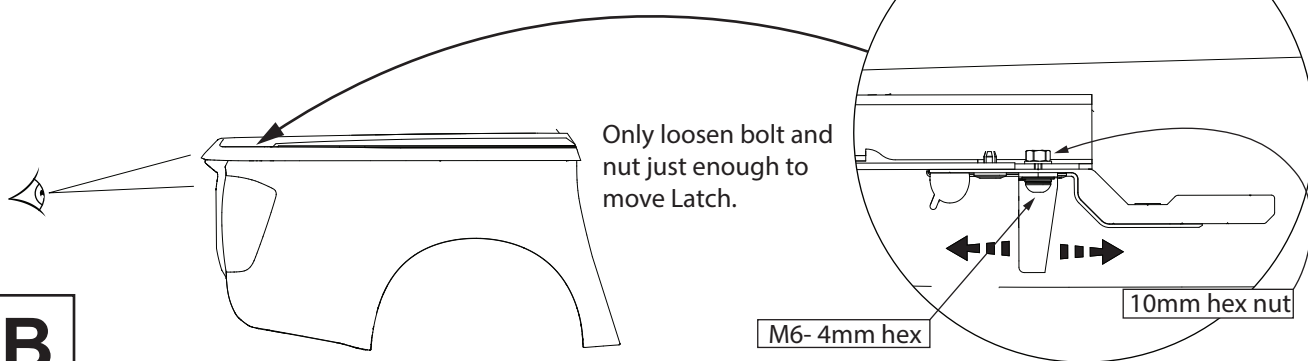

Only loosen bolt and  
nut just enough to  
move Latch.

M6- 4mm hex

10mm hex nut

**B**

### LATCHING/CLOSING ADJUSTMENT

To adjust **SPORTLID** latching,  
move latch pin up or down.

Note:  
The pin may need  
to be adjusted later after  
the seal compression  
has changed.

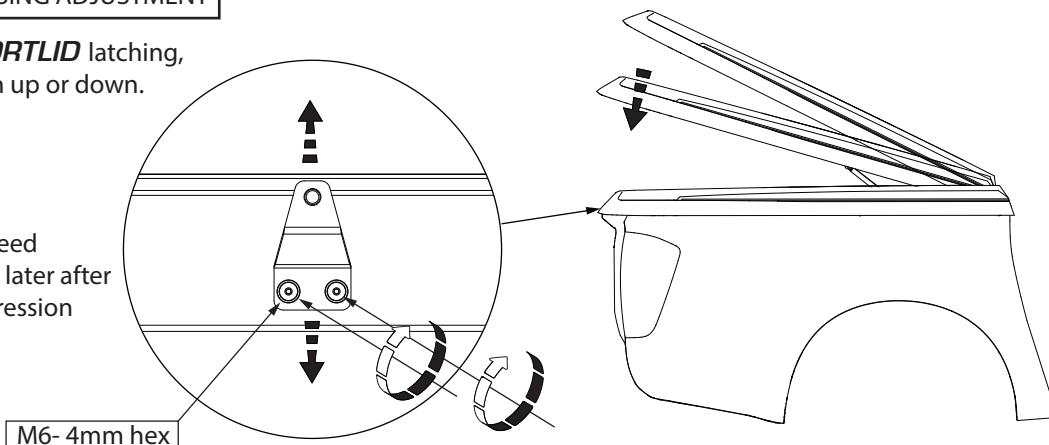

M6- 4mm hex

**C**

### GAP ADJUSTMENT

Move **SPORTLID** locators  
individually back and forward  
1-3mm to adjust the size of  
the gaps around the rear corner.

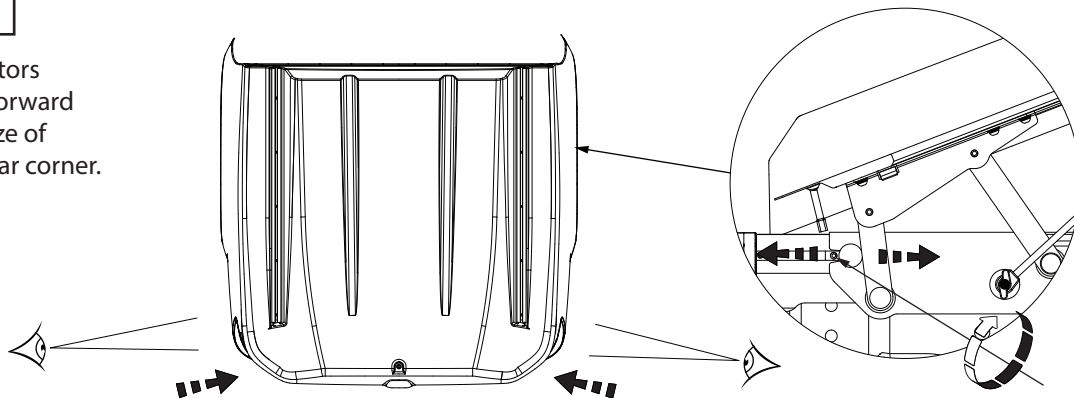

**D**

Fitting Kit Number	Manufacturer	Model Type	Year	Stockist	Cab Size	Product	Revision	Date	Page
K432	Ford	Ranger	2011	General Use	DC	SLT	3	06/07/17	8 of 9



# **SPORTLID GUIDELINES**

**PLEASE PASS THIS INFORMATION ON TO THE END USER**

1. It is important to follow fitting instructions when fitting the **SPORTLID**. As well as when refitting the **SPORTLID** after it has been removed.
2. Recommended maintenance period is after the first 1000kms, then at least every 3 months (more frequently in harsh driving conditions).
3. Check all **SPORTLID** fixing periodically to ensure they are tight and to specified settings.
4. All devices (roof bars etc.) fixed to the **SPORTLID** should be tightened correctly and checked regularly during the journey as per manufacturers' requirements.
5. It is important to ensure all loads are secured correctly and safely.
6. It is important not to exceed the load specification of the **SPORTLID**.  
MAX OPEN LOAD 20KG; MAX CLOSED LOAD 75KG.
7. The load carried has to be within the limitations of the chosen carrier system.
8. All equipment must be maintained in good working order.
9. The load shall be as evenly distributed as possible over the area of the carrier system, and the centre of gravity of the load kept as low as possible. Narrow and heavy loads (for example, metal tube) are to be carried near the feet of the carrier system. Loads which overhang the ends of the carrier system shall conform to any relevant laws or by-laws in force, and shall be adequately secured.
10. Loads shall be adequately secured using suitable straps or similar tightening devices. After loading, recheck the security of the load and roof bars regularly throughout the journey. Elastic straps with securing hooks shall not be used.
11. Where surfboards are carried (or similar items which may produce lifting forces), they shall not be carried side by side, but stacked one upon the other. All surfboards and similar items shall be secured independently to the front and rear of the carrier system using straps or other methods which are capable of withstanding the lifting forces.
12. Where specialized accessories are available to carry or secure loads, for example cycle carriers, it is recommended that they are used.
13. The handling characteristics of a vehicle will change when the carrier system is fitted and especially when it is loaded (in particular, crosswind sensitivity, handling on bends, and braking). Driving techniques should be altered to allow for these changes, reducing speed, especially on bends, and allowing for longer braking distances.

Fitting Kit Number	Manufacturer	Model Type	Year	Stockist	Cab Size	Product	Revision	Date	Page
K432	Ford	Ranger	2011	General Use	DC	SLT	3	06/07/17	9 of 9