



INSTALLATION INSTRUCTIONS (K1027) SLT TOP RAIL REPLACEMENT KIT

IMPORTANT

- Vehicle bodies and vehicle specific installation can vary, so please read the following instructions as they refer to important information which could affect the quality of the final installation.
- It is strongly advisable that the **SPORTLID** installation is performed by an authorised dealer.
- Screw torques must be adhered to, otherwise the warranty may become void.
- If a **Bedliner** or a **SPORTGUARD** are fitted there maybe some additional trimming required.
- Recommended installation by 2 people.

Use appropriate safety equipment when fitting the *SPORTLID*.

Protective eyewear



Hearing protection



Warranty

- For warranty information please see your authorised dealer.







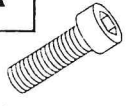

TOOLS REQUIRED

- Hex keys 3, 4, 5, 6mm
- 8,10mm spanners
- 1/4 Inch Torque wrench 0-10Nm
- 1/4 Inch Hex key sockets 3, 4, 5, 6m
- Cleaning cloths/Rags
- Phillips head screw driver

Fitting Kit Number	Manufacturer	Model Type	Year	Stockist	Cab Size	Product	Revision	Date	Page
K1027	ALL	NA		General Use		SLT	2	9/04/2018	1 of 5

SPORTLID FOR TANGO PARTS

C-CHANNEL PARTS

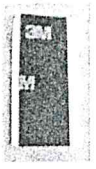
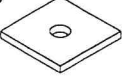
<p>A</p> <p>X4</p>  <p>M5x30mm Socket Hex</p>	<p>B</p> <p>X6</p>  <p>M5x22mm Socket Hex</p>	<p>C</p> <p>X10</p>  <p>M5x1.6mm Nylon washer</p>	<p>D</p> <p>X10</p>  <p>8mm Spacer</p>	<p>E</p> <p>X4</p>  <p>M5 Dome Nut</p>	<p>F</p> <p>X4</p>  <p>M5 Spring Washer</p>	<p>G</p> <p>X4</p>  <p>9mm Spacer</p>	<p>H</p>  <p>1.5mm Gauge</p>
<p>I</p> <p>X2</p>  <p>M10 Retainer Washer</p>	<p>J</p> <p>X2</p>  <p>3M Tab</p>	<p>K</p> <p>X10</p>  <p>Rubber Seal</p>					

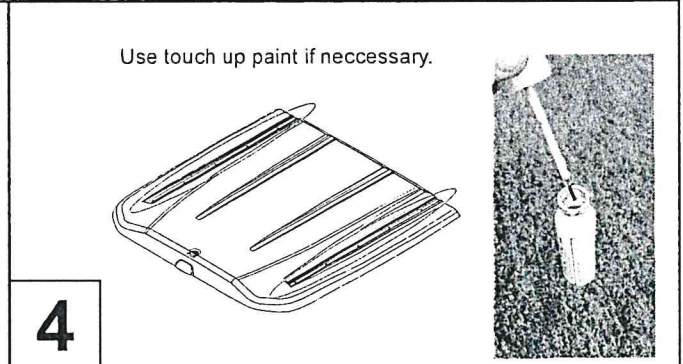
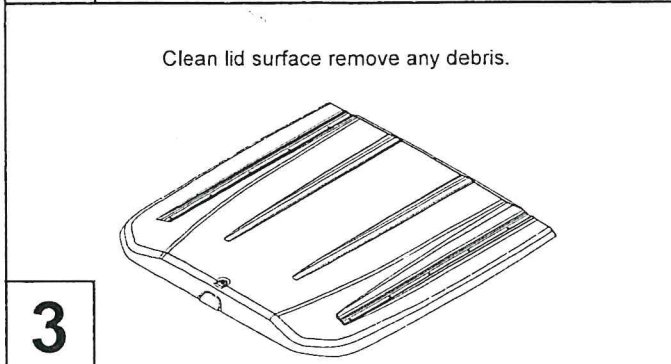
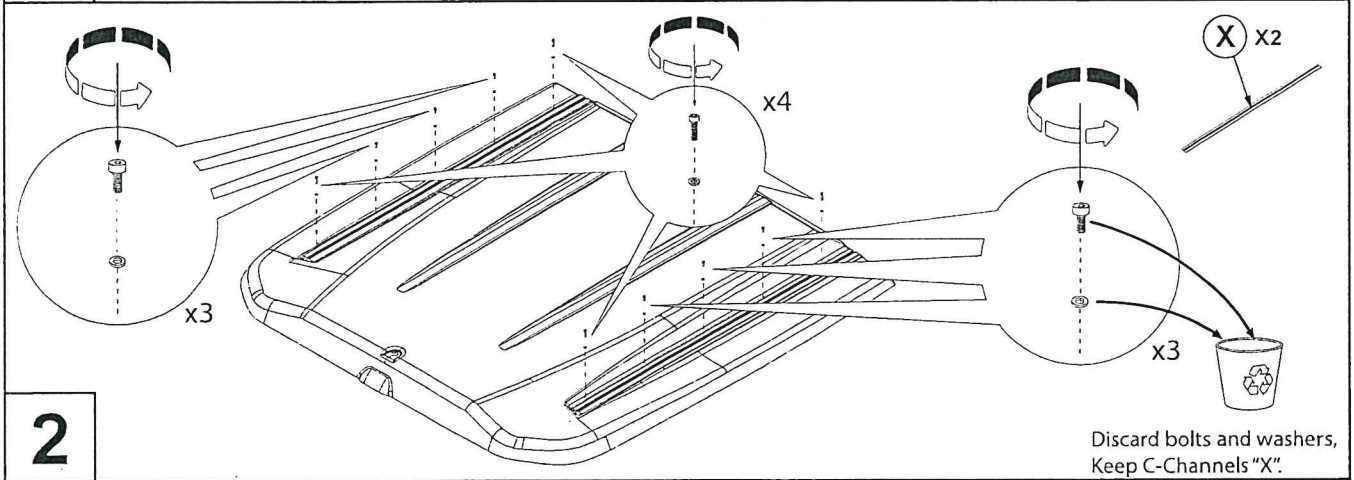
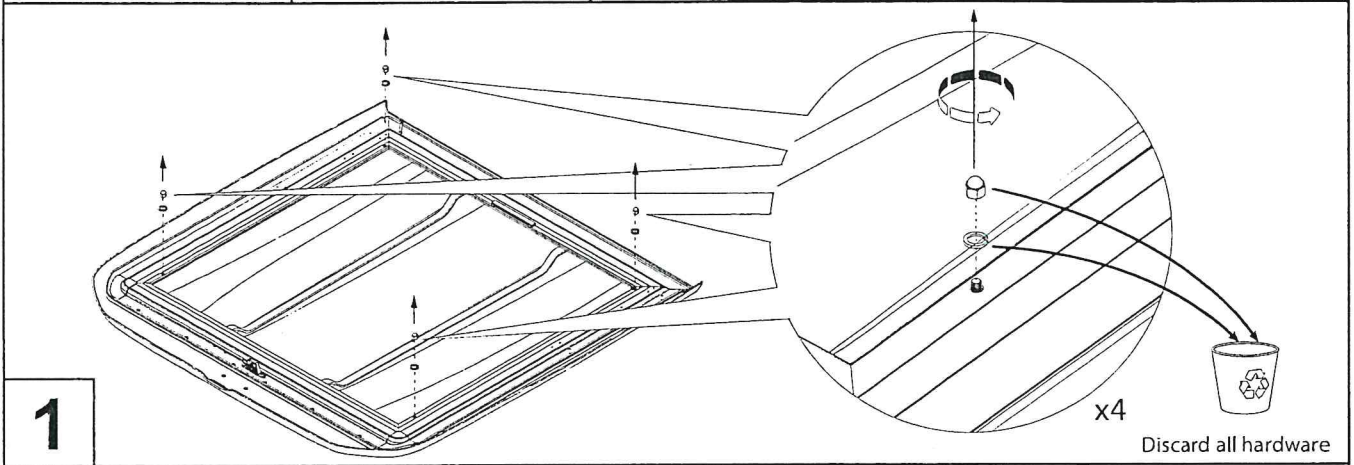

Fitting Kit Number	Manufacturer	Model Type	Year	Stockist	Cab Size	Product	Revision	Date	Page
K1027	ALL	NA		General Use		SLT	2	9/04/2018	2 of 5

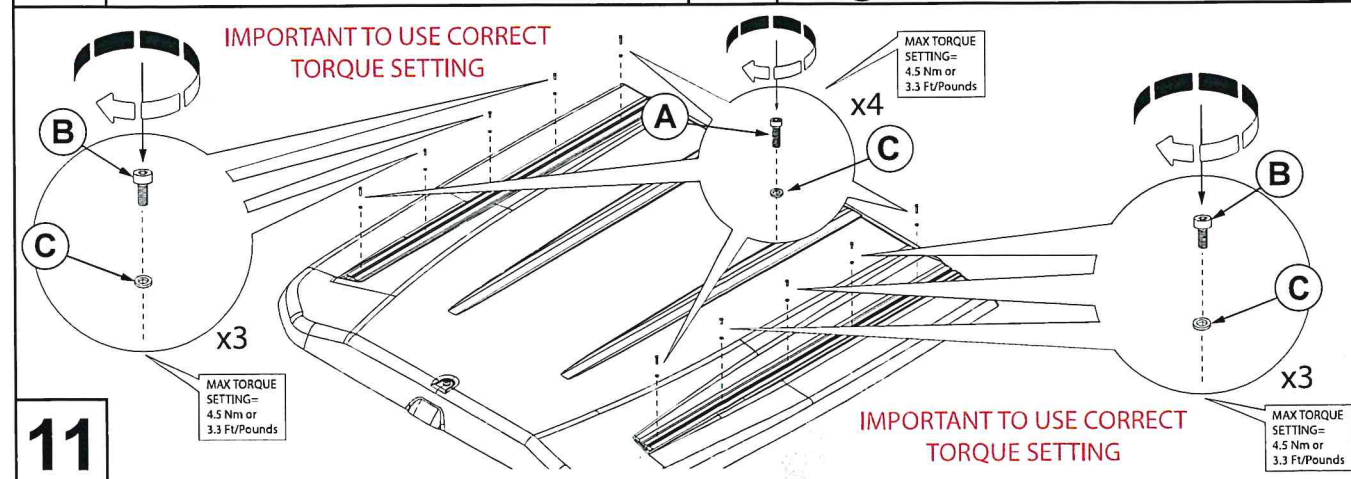
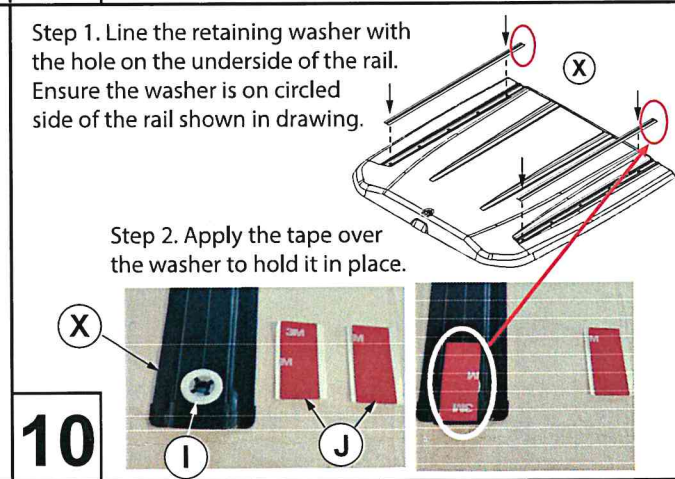
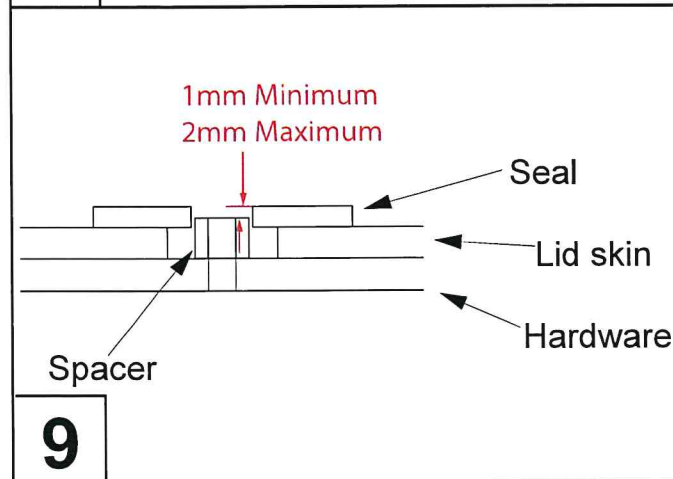
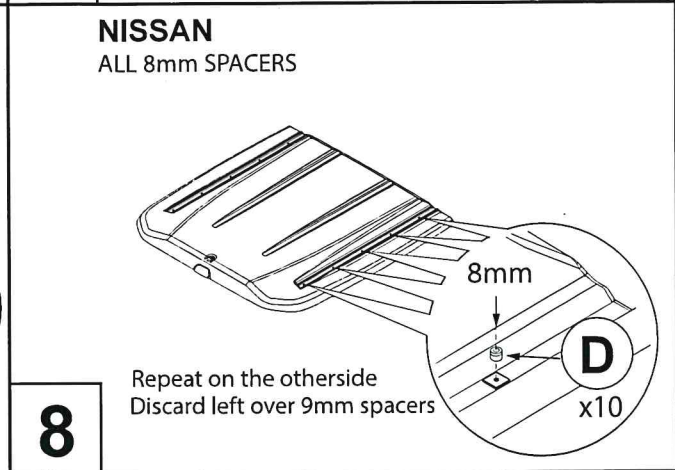
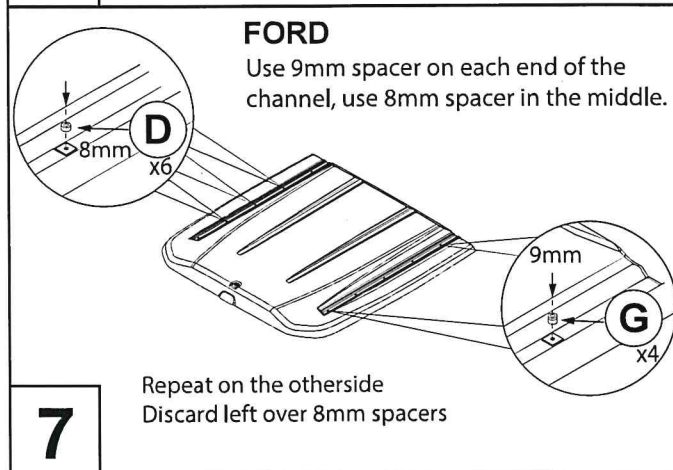
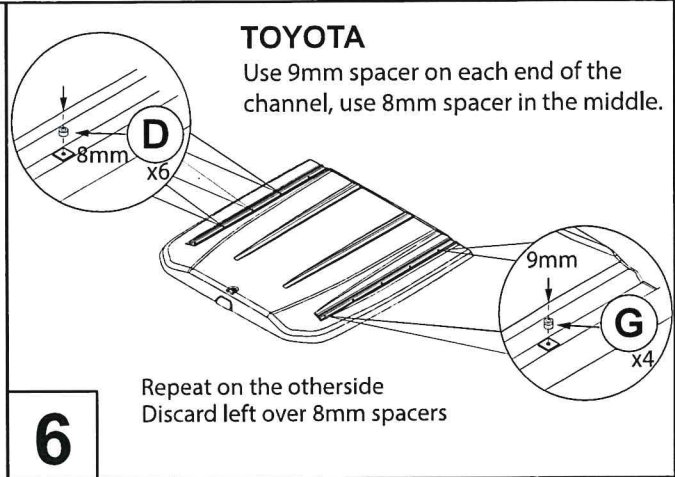
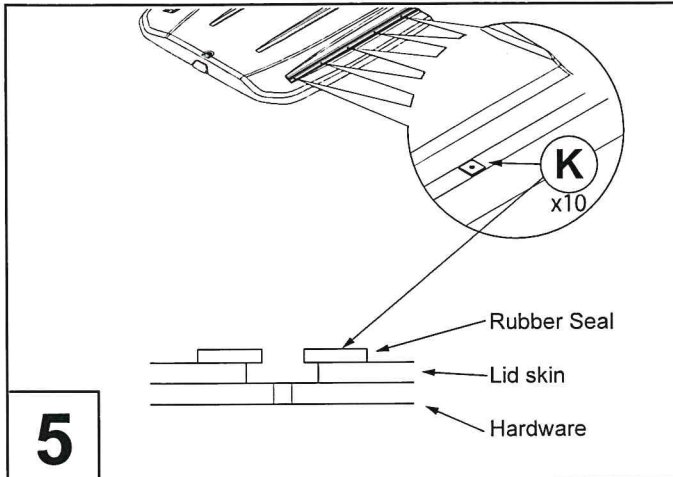

Fitting Kit Number	Manufacturer	Model Type	Year	Stockist	Cab Size	Product	Revision	Date	Page
K1027	ALL	NA		General Use		SLT	2	9/04/2018	3 of 5

12

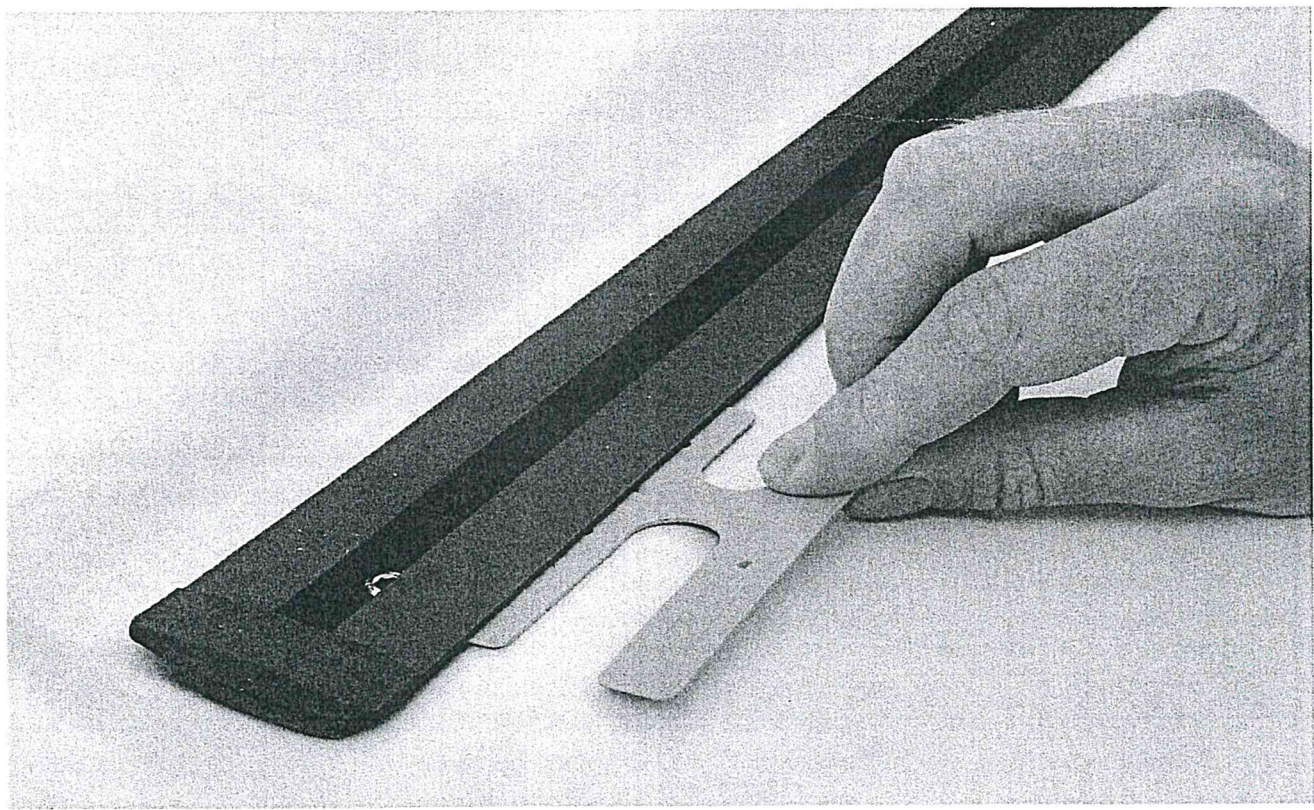
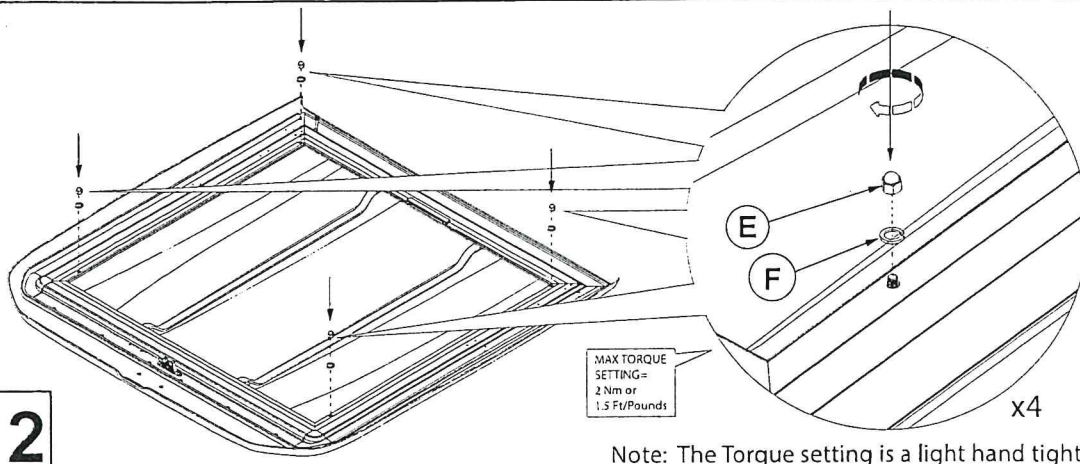

13

Use gauge supplied to check clearance from channel to lid. Gauge should fit easily.

Fitting Kit Number	Manufacturer	Model Type	Year	Stockist	Cab Size	Product	Revision	Date	Page
K1027	ALL	NA		General Use		SLT	2	9/04/2018	4 of 5

SPORTLID GUIDELINES

PLEASE PASS THIS INFORMATION ON TO THE END USER

1. It is important to follow fitting instructions when fitting the **SPORTLID**. As well as when refitting the **SPORTLID** after it has been removed.
2. Recommended maintenance period is after the first 1000kms, then at least every 3 months (more frequently in harsh driving conditions).
3. Check all **SPORTLID** fixing periodically to ensure they are tight and to specified settings.
4. All devices (roof bars etc.) fixed to the **SPORTLID** should be tightened correctly and checked regularly during the journey as per manufacturers' requirements.
5. It is important to ensure all loads are secured correctly and safely.
6. It is important not to exceed the load specification of the **SPORTLID**.
MAX OPEN LOAD 20KG; MAX CLOSED LOAD 75KG.
7. The load carried has to be within the limitations of the chosen carrier system.
8. All equipment must be maintained in good working order.
9. The load shall be as evenly distributed as possible over the area of the carrier system, and the centre of gravity of the load kept as low as possible. Narrow and heavy loads (for example, metal tube) are to be carried near the feet of the carrier system. Loads which overhang the ends of the carrier system shall conform to any relevant laws or by-laws in force, and shall be adequately secured.
10. Loads shall be adequately secured using suitable straps or similar tightening devices. After loading, recheck the security of the load and roof bars regularly throughout the journey. Elastic straps with securing hooks shall not be used.
11. Where surfboards are carried (or similar items which may produce lifting forces), they shall not be carried side by side, but stacked one upon the other. All surfboards and similar items shall be secured independently to the front and rear of the carrier system using straps or other methods which are capable of withstanding the lifting forces.
12. Where specialized accessories are available to carry or secure loads, for example cycle carriers, it is recommended that they are used.
13. The handling characteristics of a vehicle will change when the carrier system is fitted and especially when it is loaded (in particular, crosswind sensitivity, handling on bends, and braking). Driving techniques should be altered to allow for these changes, reducing speed, especially on bends, and allowing for longer braking distances.

Fitting Kit Number	Manufacturer	Model Type	Year	Stockist	Cab Size	Product	Revision	Date	Page
K1027	ALL	NA		General Use		SLT	2	9/04/2018	5 of 5