

INSTALLATION INSTRUCTIONS

EGR *ROLLTRAC*

ELECTRIC

Vehicle Model: FORD RANGER
Year of manufacture: MY22 onwards



IMPORTANT:

IF THE EGR ROLLTRAC IS FITTED TO THE VEHICLE WITH **ANY ACCESSORY LOADED WITH MORE THAN 45KG**, A TUB REINFORCEMENT KIT **MUST** BE FITTED. THE TUB REINFORCEMENT KIT CAN BE PURCHASED FROM YOUR LOCAL FORD DEALER OR DIRECTLY FROM EGR (PART No. KIT040256).

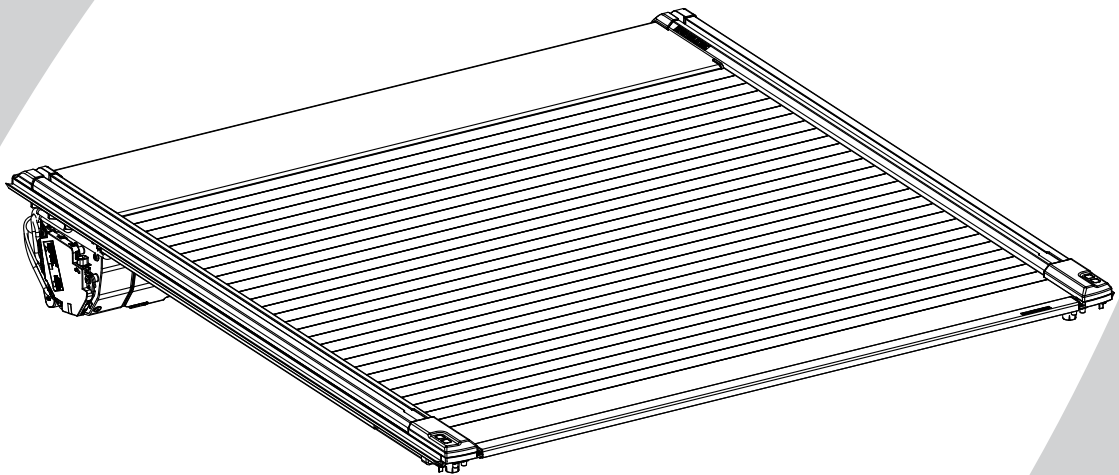

Installation time: 180 minutes (without tubliner)

Caution

- Do not attach EGR RollTrac in a location or by a method not specified.
- Do not use this product for any vehicle make or model, other than those specified in this document.
- Do not remove the plaque or label from this product.
- Do not modify the structure of the EGR RollTrac in any way.

General Notes

- Read through the fitting instructions before installation of EGR RollTrac.
- Always install the accessory following the fitting instructions. Failure to do so may cause damage to the vehicle or the accessory.
- Ensure all recyclable discarded vehicle accessory components and packaging are recycled following local recycling regulations.
- It is always recommended that this accessory is fitted by a qualified Technician.
- Safely store and protect any removed vehicle components.
- Ensure all bare metal surfaces are protected using Automotive Bare Metal Primer and touch-up paint.
- Remove all metal swarf and dust from all vehicle surfaces if surface is used for accessory installation.

Safety Notes

- Check that all work practices comply with safety standards.
- Please wear appropriate clothing and use safety equipment.



INSTALLATION PROCESS

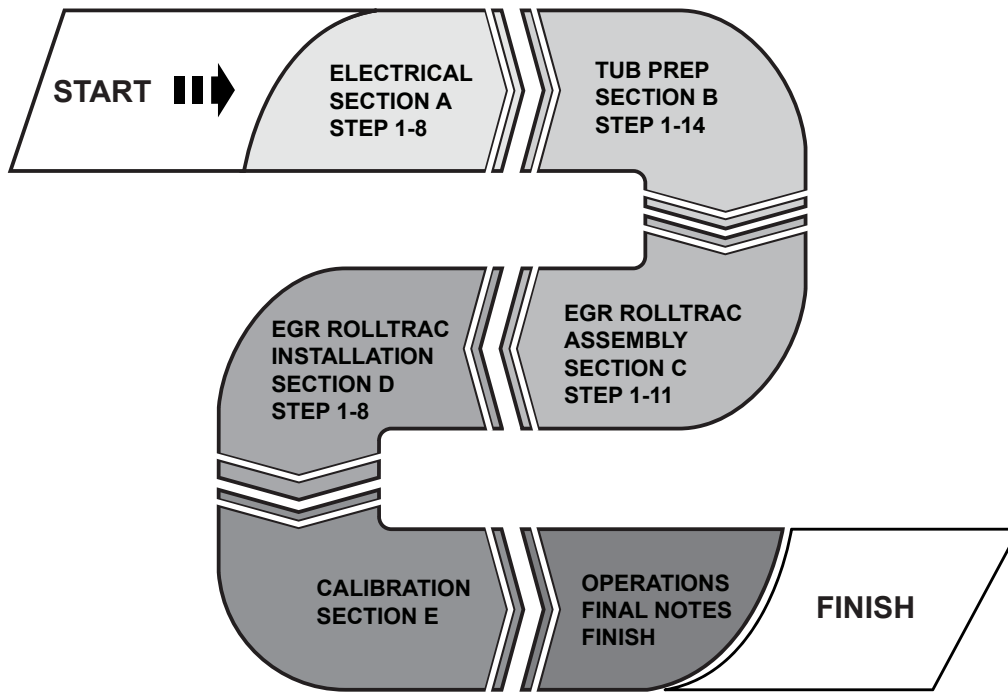

UNPACKING

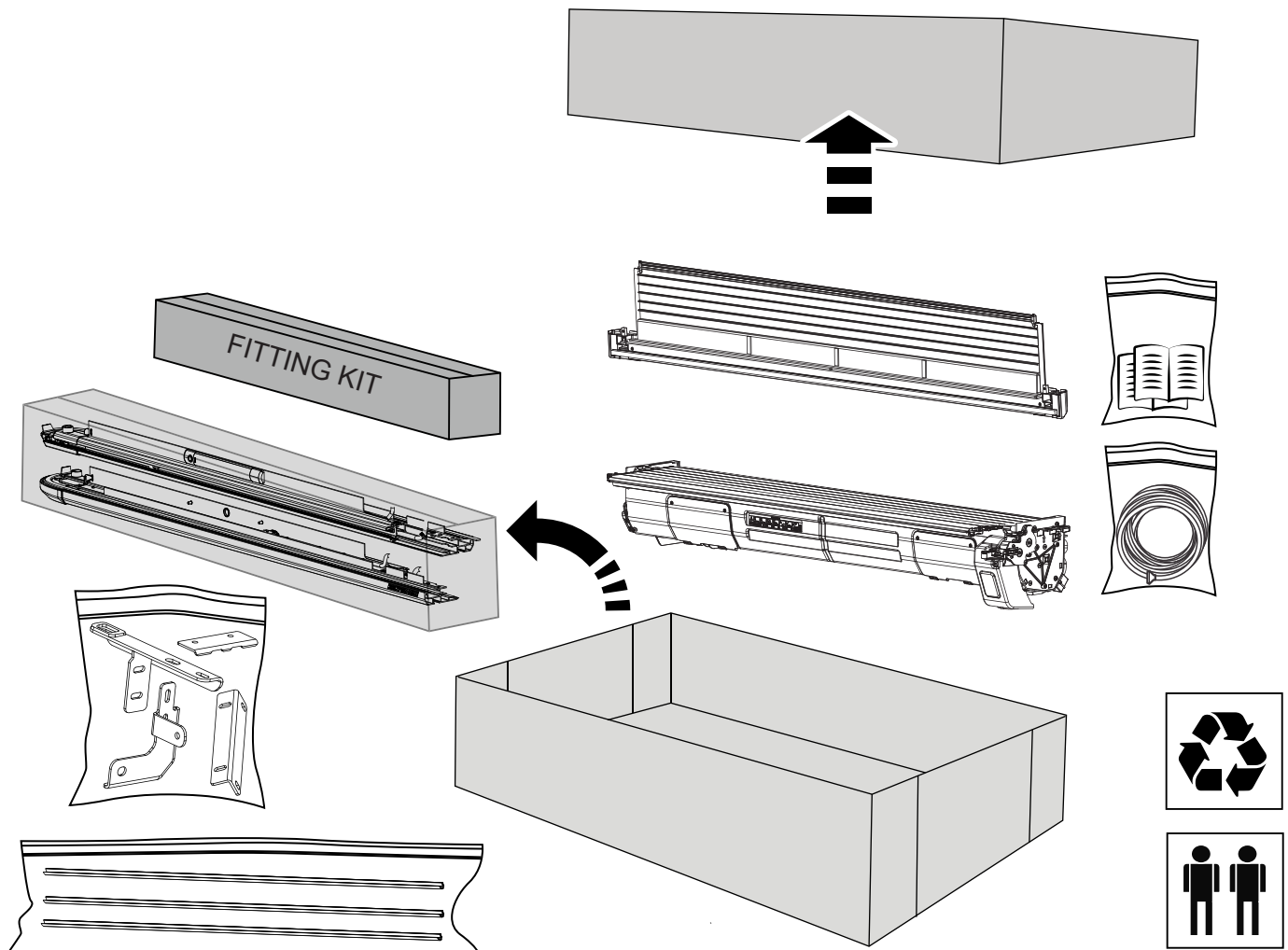

KIT CONTENTS - COMPONENT NUMBER AND QUANTITY

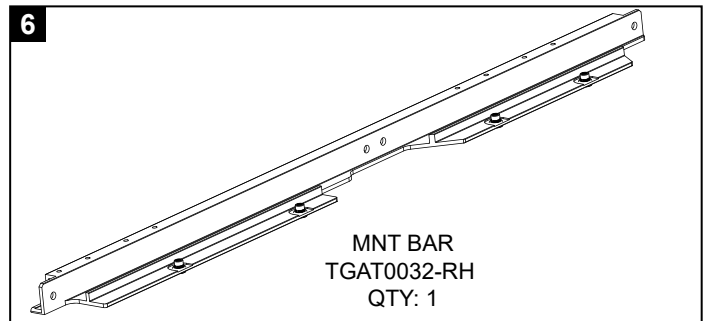
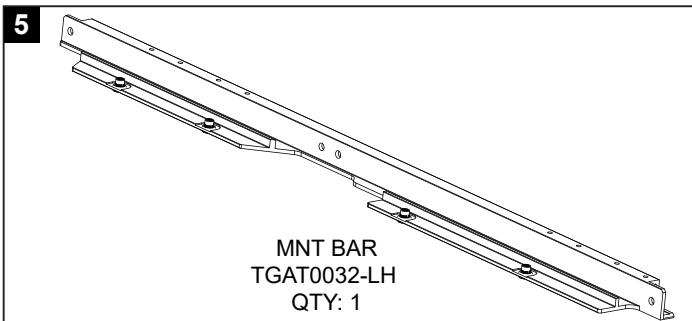
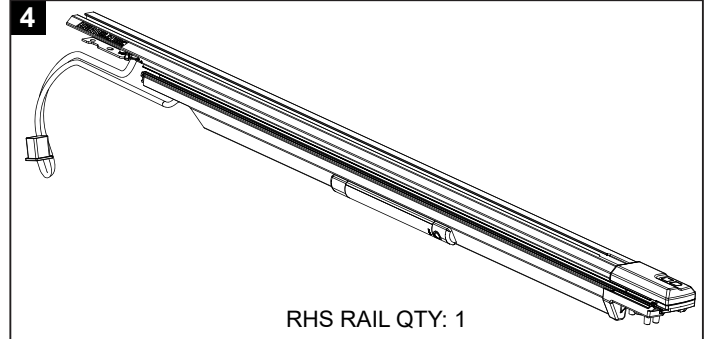
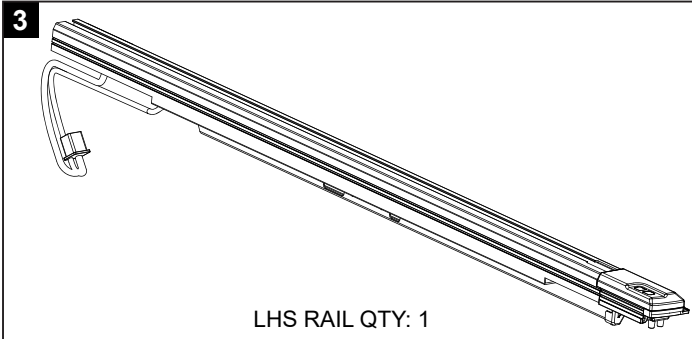
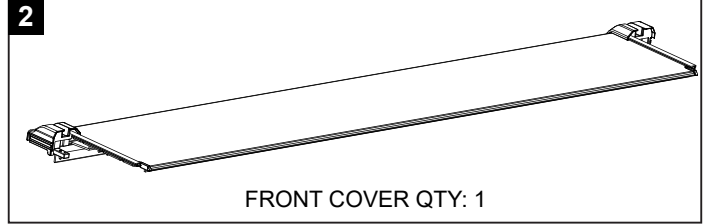
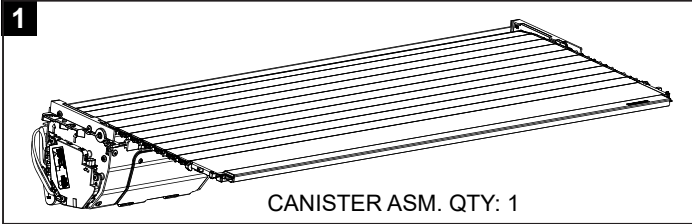

EGR EGR ROLLTRAC CLAMP KIT IN BAG

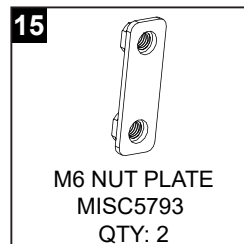
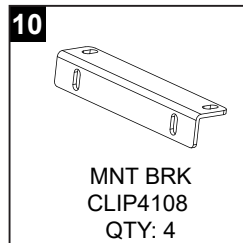
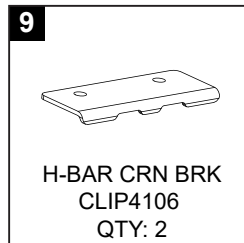
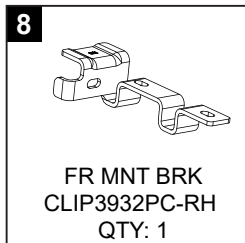
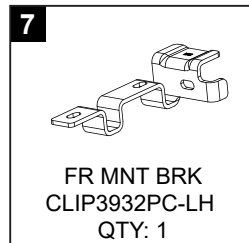

EGR EGR ROLLTRAC BULB KIT IN BAG

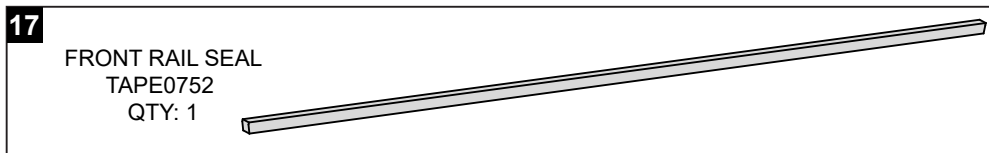
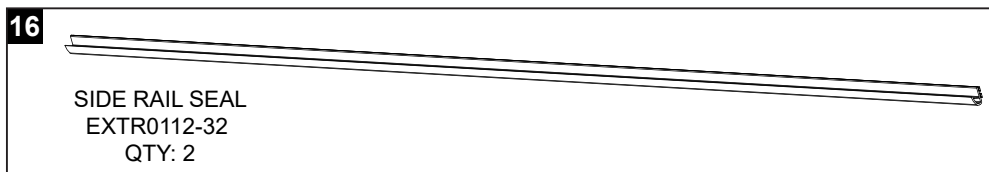

EGR EGR ROLLTRAC MBAR HARDWARE KIT IN BAG

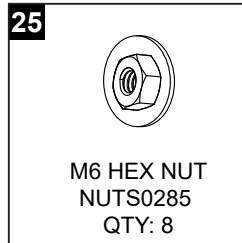
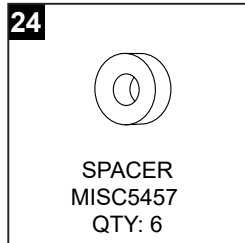
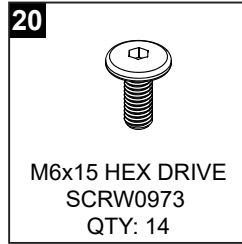
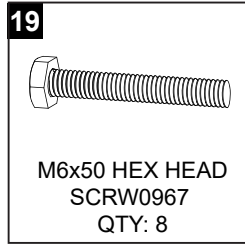

EGR EGR ROLLTRAC FITTING KIT IN BOX

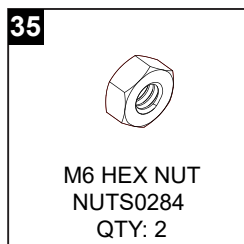
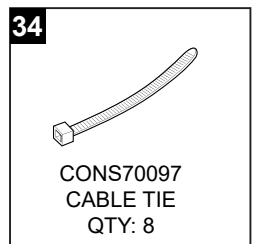
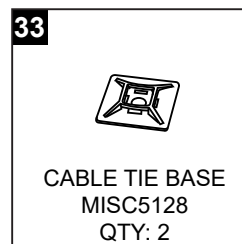
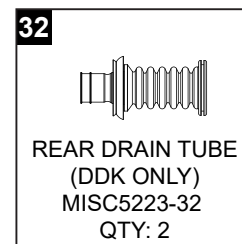
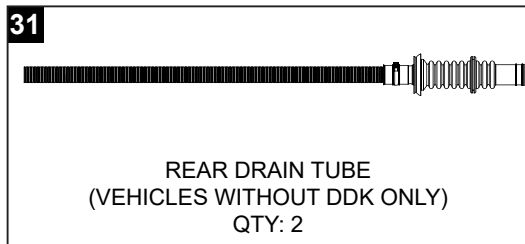
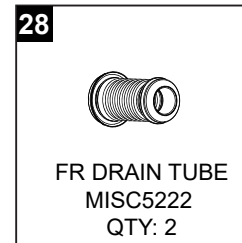
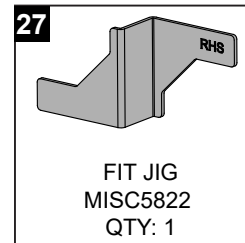
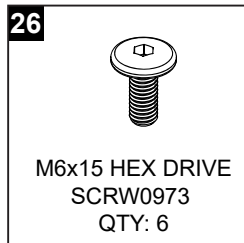

PARTS IN VEHICLE HARNESS

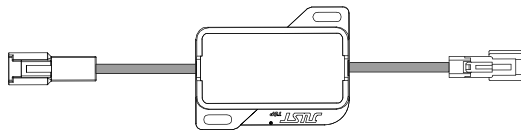

SPP UNIT

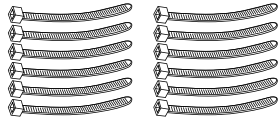

CABLE TIE
QTY: 12



25A FUSE



MINI FUSE

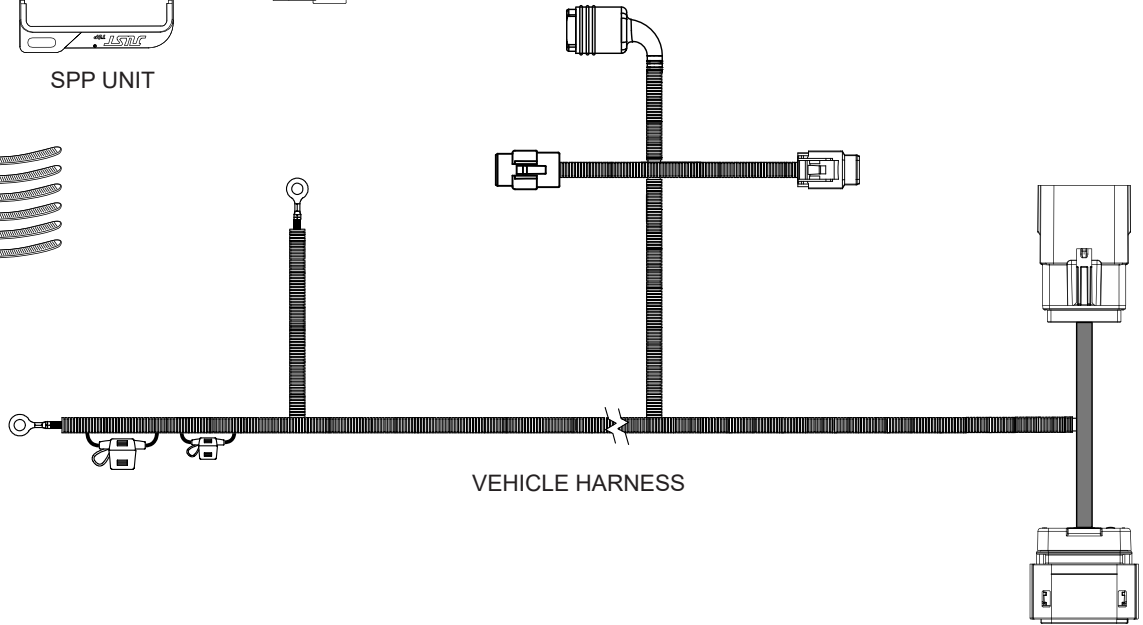

VEHICLE HARNESS



TOOLS REQUIRED - NOT SUPPLIED IN KIT

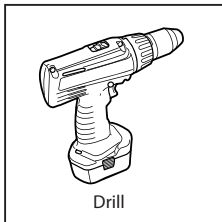

Drill

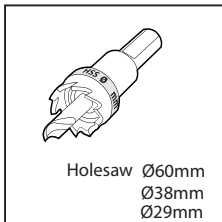

Holesaw Ø60mm
Ø38mm
Ø29mm

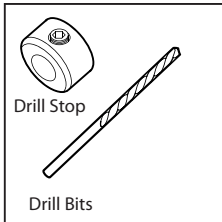

Drill Stop
Drill Bits

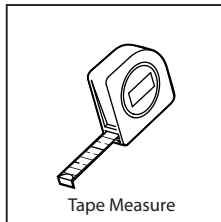

Tape Measure

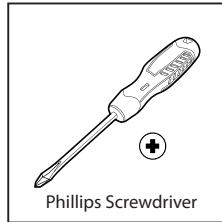

Phillips Screwdriver

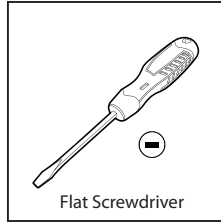

Flat Screwdriver

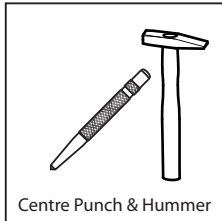

Centre Punch & Hammer

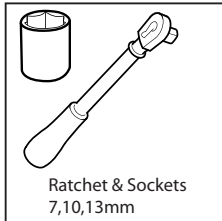

Ratchet & Sockets
7,10,13mm

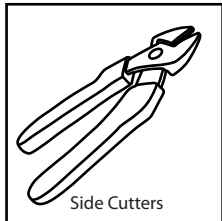

Side Cutters

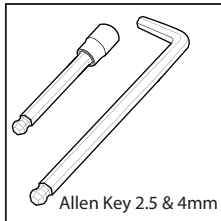

Allen Key 2.5 & 4mm

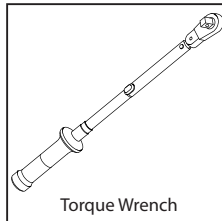

Torque Wrench

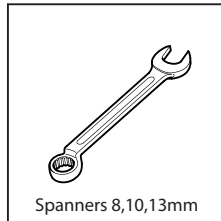

Spanners 8,10,13mm



Anti-abrasion tape to seal
holes & slots

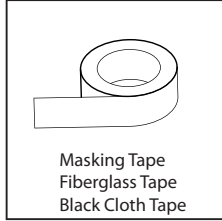

Masking Tape
Fiberglass Tape
Black Cloth Tape

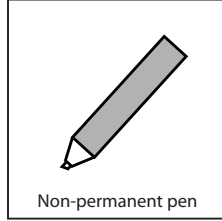

Non-permanent pen

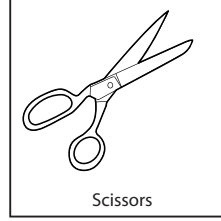

Scissors

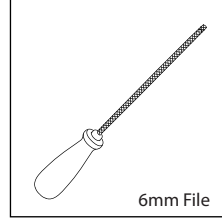

6mm File

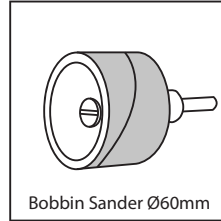

Bobbin Sander Ø60mm

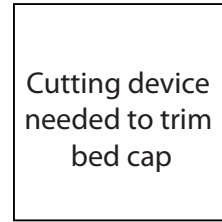

Cutting device
needed to trim
bed cap

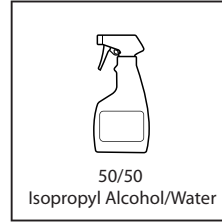

50/50
Isopropyl Alcohol/Water

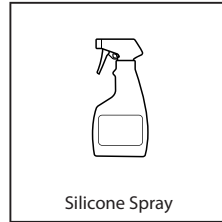

Silicone Spray

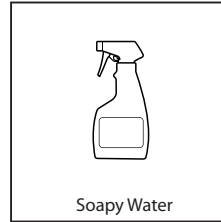

Soapy Water



ANTI RUST
Rust Inhibitor

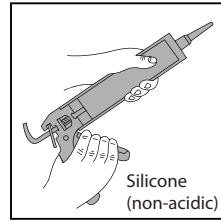

Silicone
(non-acidic)

GLOSSARY:

- 1** Number inside a square indicate part number
- 1** Number inside circle indicate the sequence within a step
- 1** Number inside the hexagon indicate torque instruction

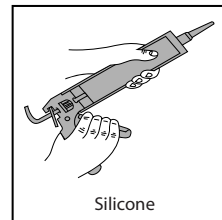

Silicone

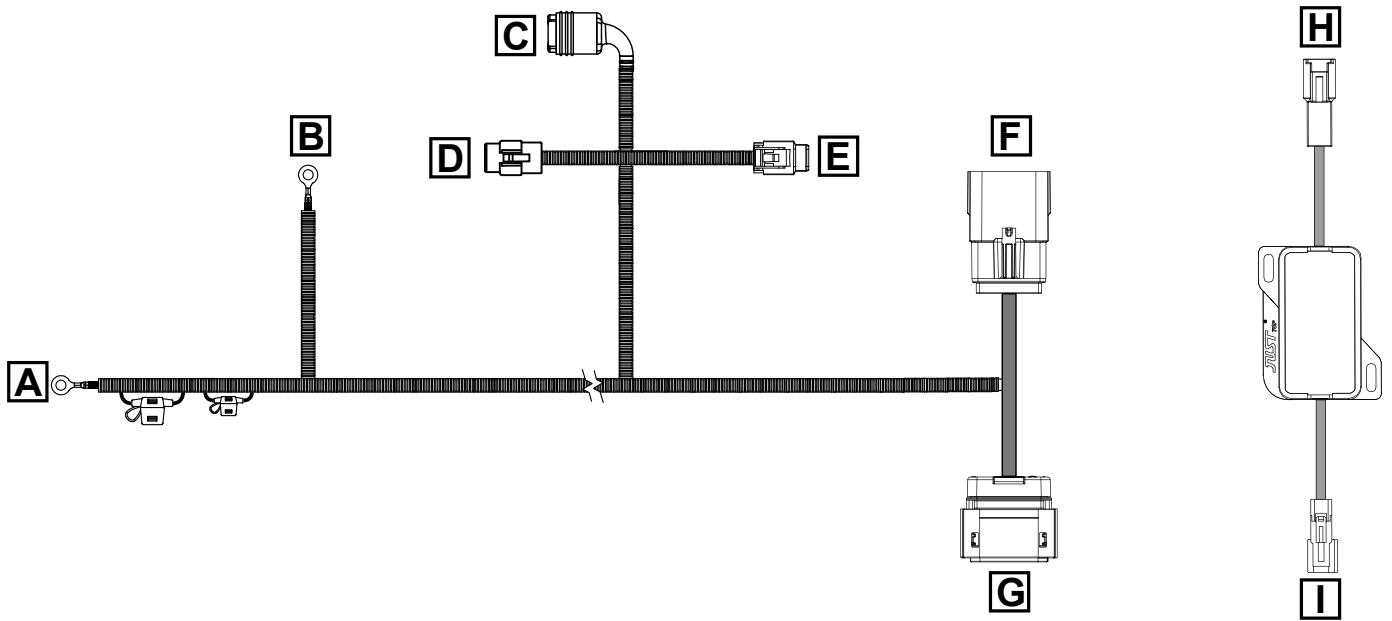

**IMPORTANT: DISCONNECT CAR BATTERY NEGATIVE TERMINAL.
FIT THE SUPPLIED FUSES AT THE END OF INSTALLATION.**

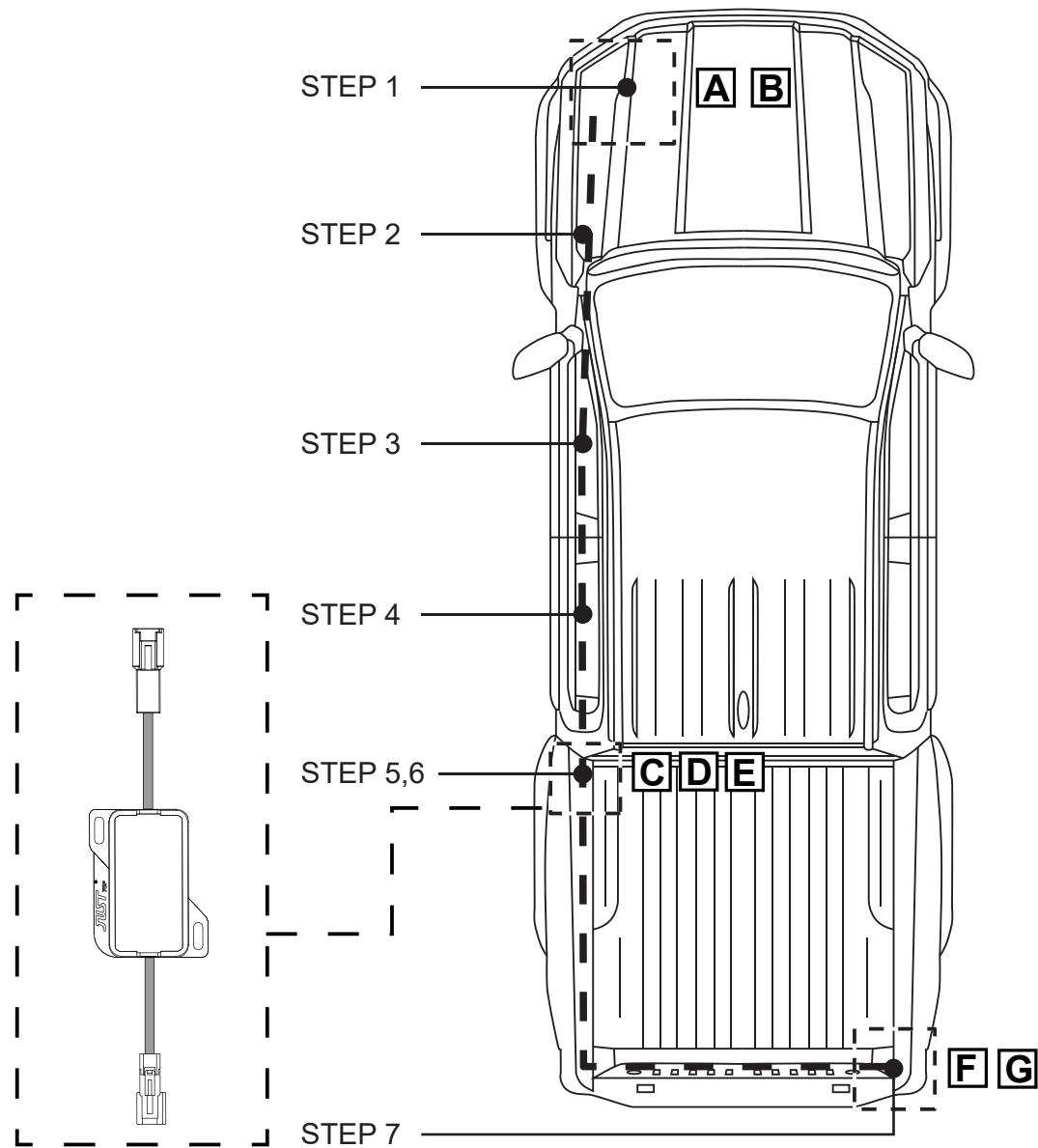

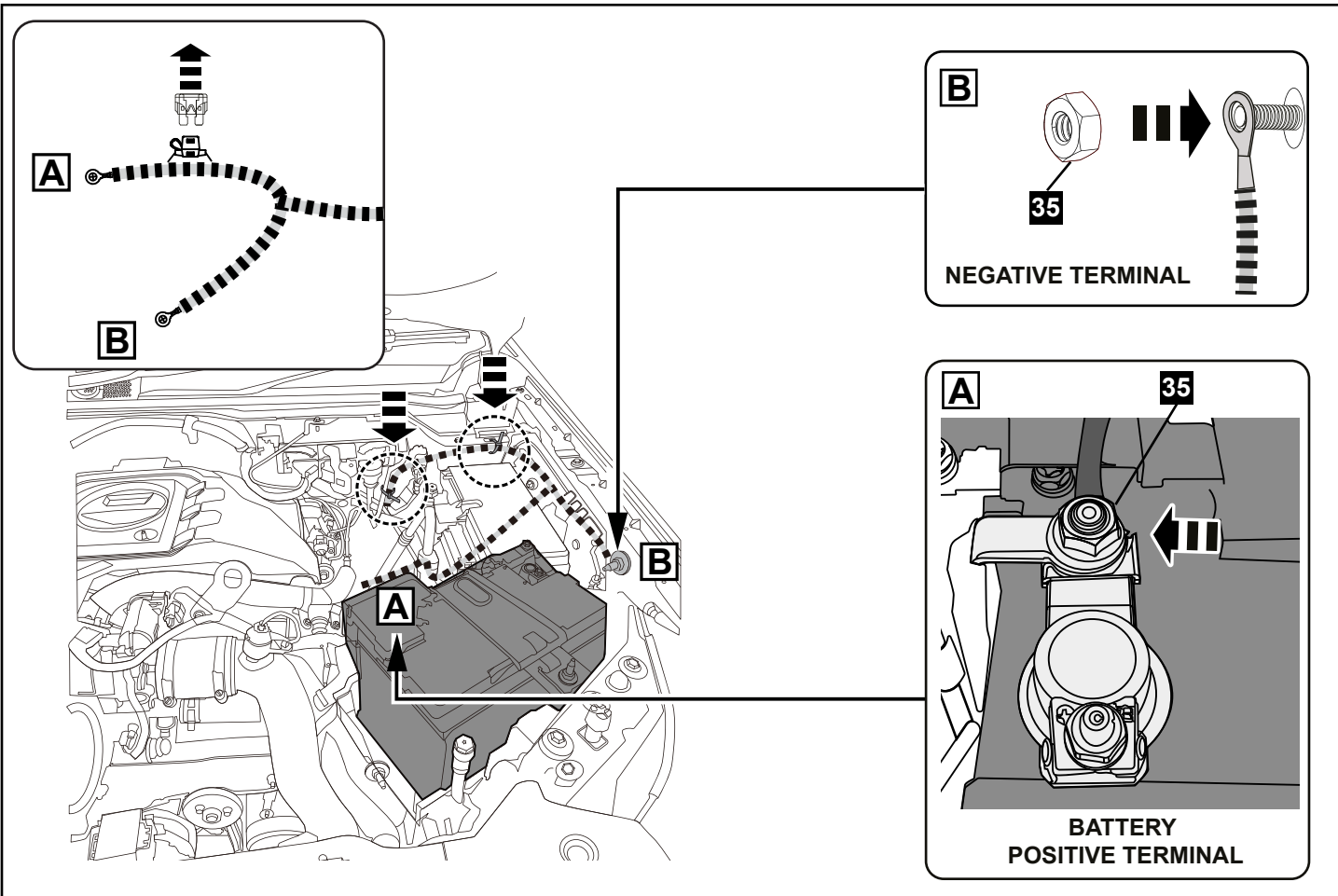

- 1 IMPORTANT:** Make sure the fuses are not fitted before making connection.
 Connect the vehicle harness branch (B) to vehicle body negative ground as shown and secure with M6 hex nut (35).
 Connect the vehicle harness branch (A) to the positive terminal of the battery and secure with M6 hex nut (35).
 Once it is positioned, secure in place using two cable ties as shown.

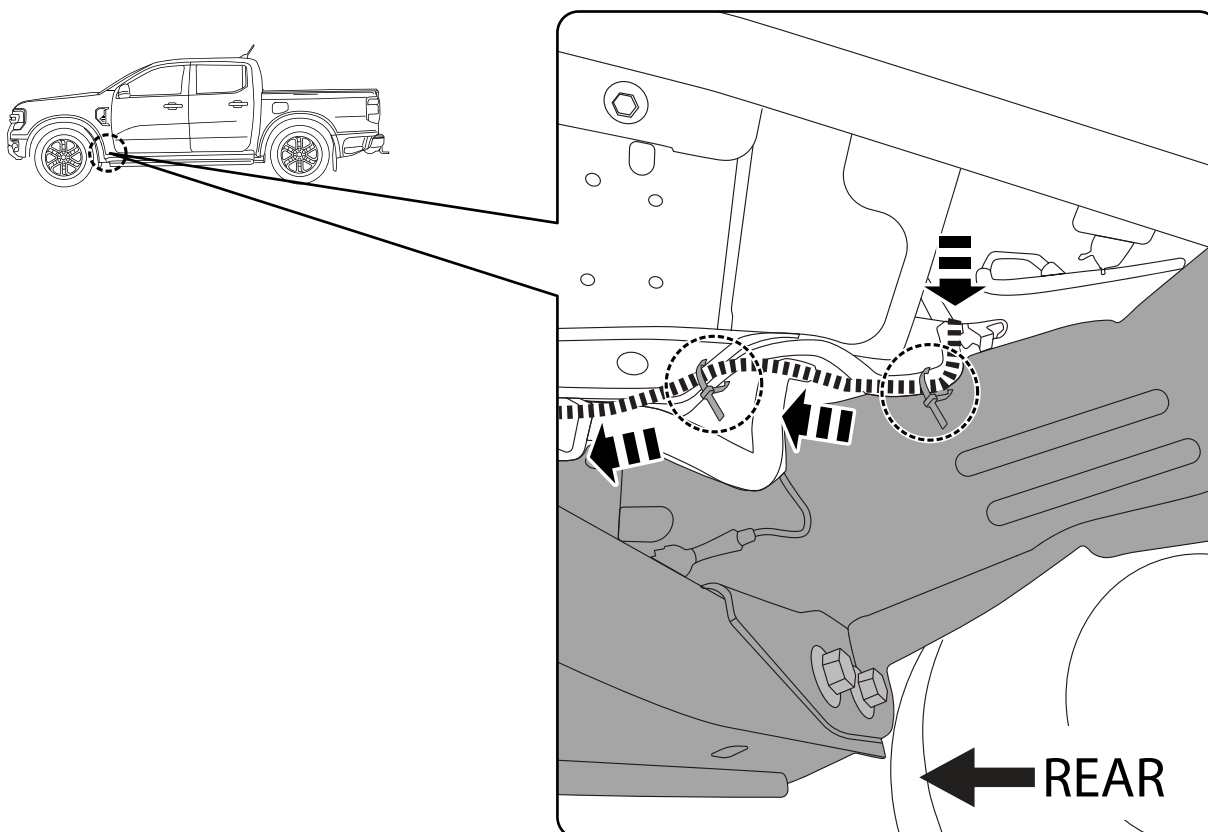

- 2** Pull the vehicle harness from engine bay down to the floor behind the front left wheel. Direct it towards the rear of the vehicle. Secure the vehicle harness to the vehicle loom in the two areas shown using cable ties.

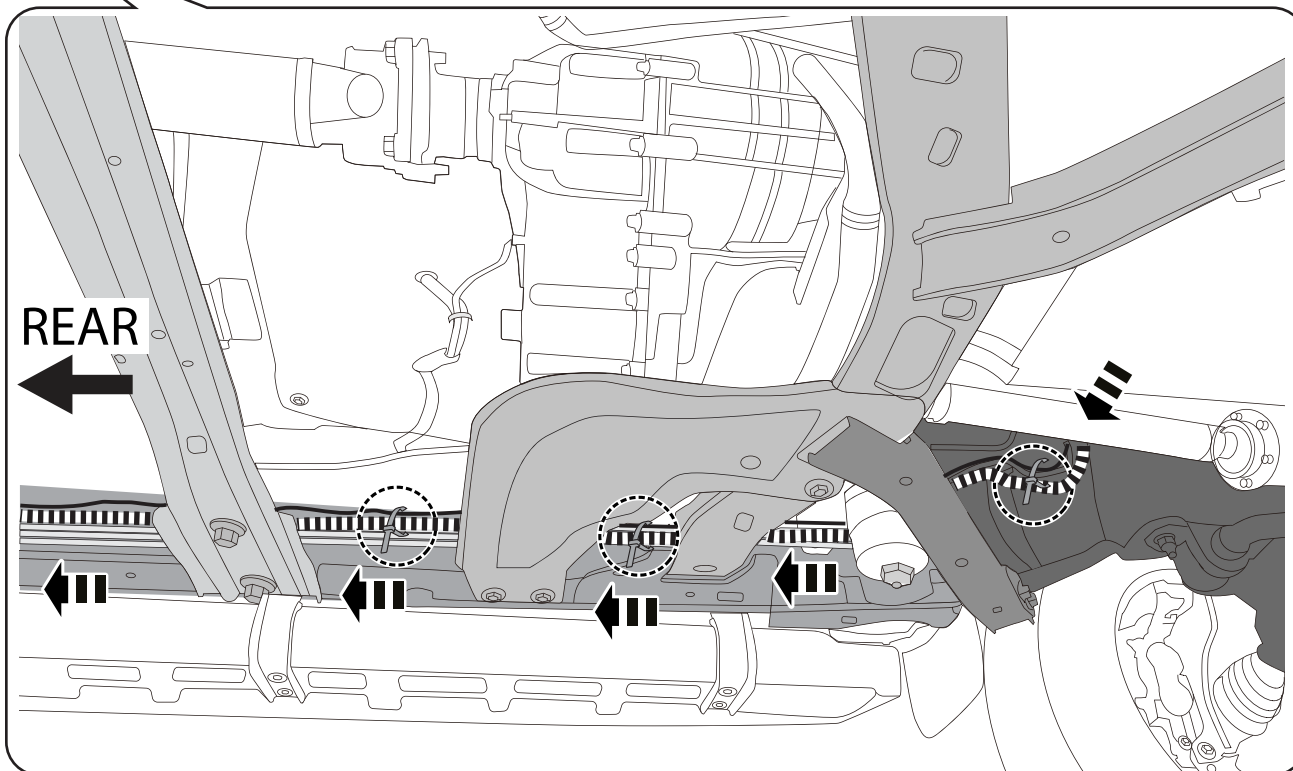
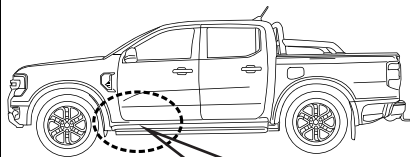

3 Continue to the rear along the **chassis rail inner side (above the crossmembers)**. Secure the vehicle harness to the existing vehicle harness as shown using cable ties.

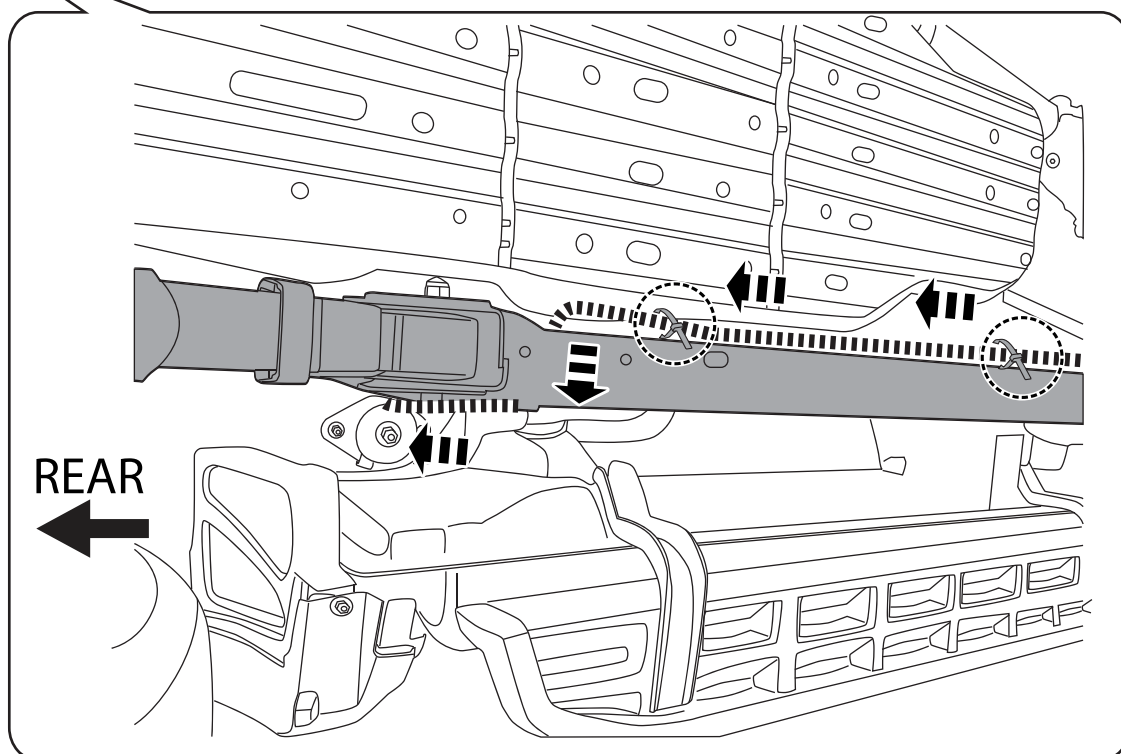
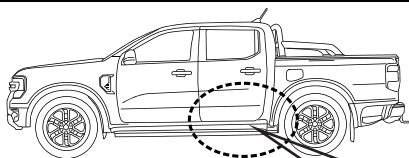

4 Continue running the vehicle harness along the **chassis rail inner side**. Feed the harness to the **outside of the chassis rail (over the top of the rail)** at the rear wheel arch as shown. Secure with two cable ties as shown.

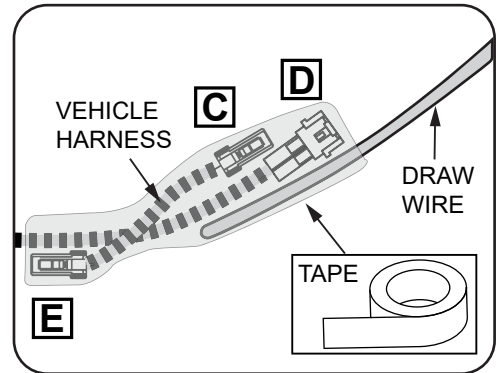
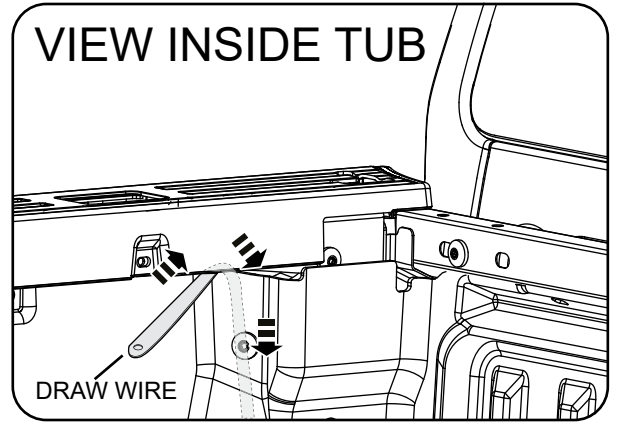
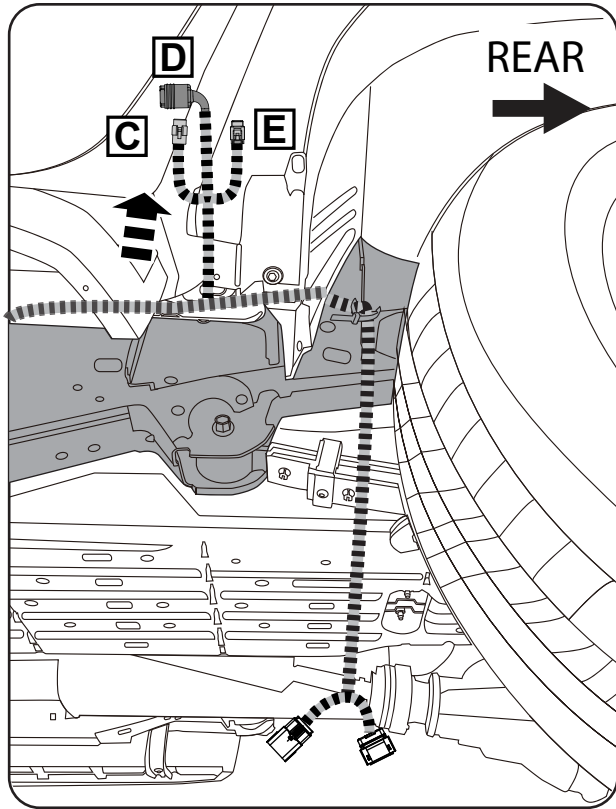

- 5** Push a draw wire down through the opening in the front LHS of the tub. Under the tub, wrap the vehicle harness connectors: **C, D & E** to the draw wire as shown. Pull them up into the tub until approximately 300mm protrudes. Remove tape and draw wire from the harness.

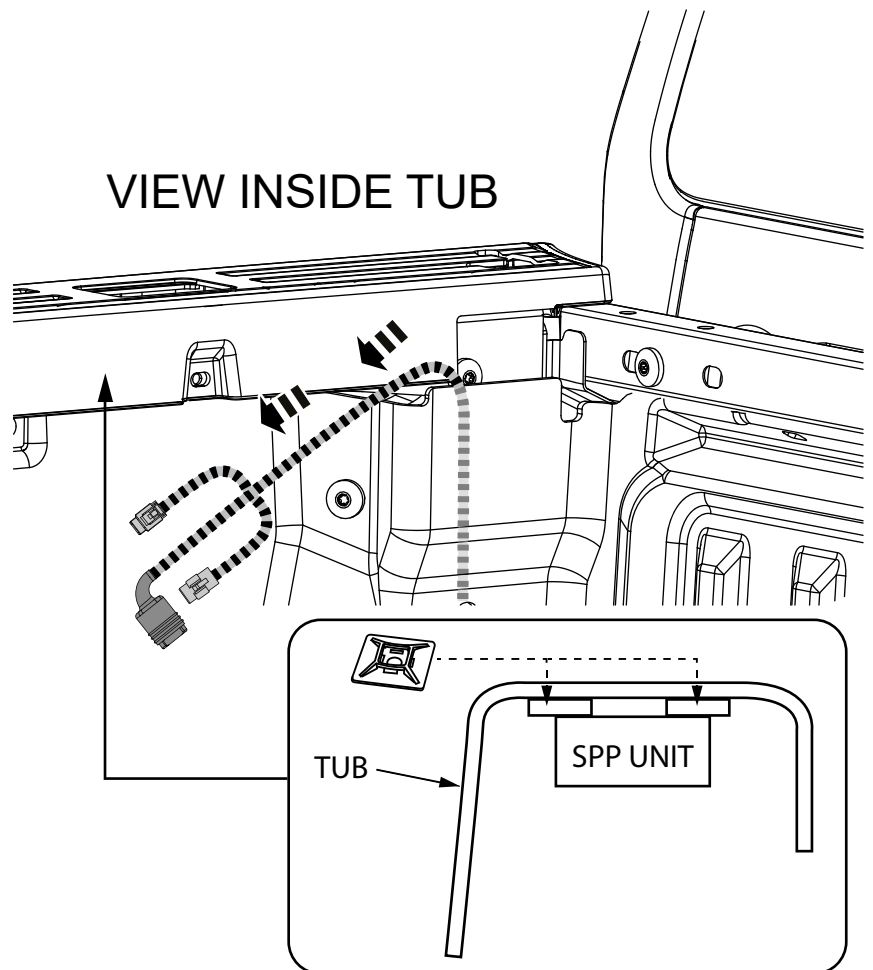
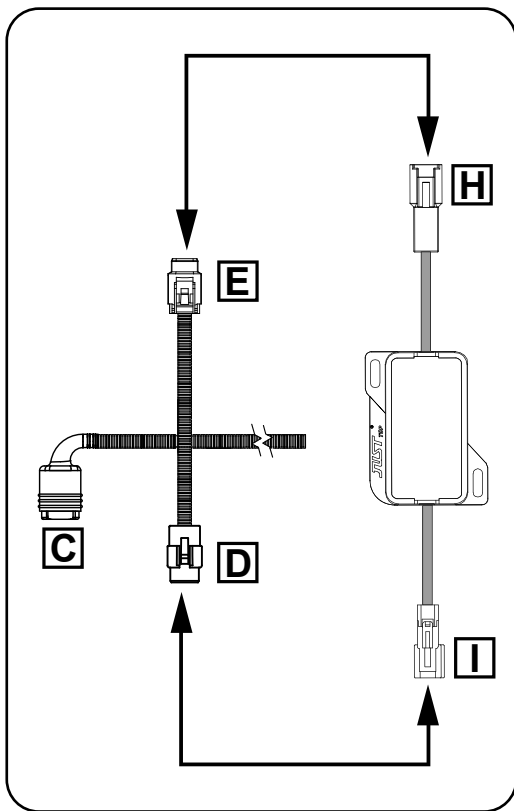

- 6** Connect the SPP unit to the vehicle harness as shown. Secure SPP unit and connectors to underside of tub flange using cable ties and cable tie base x2.

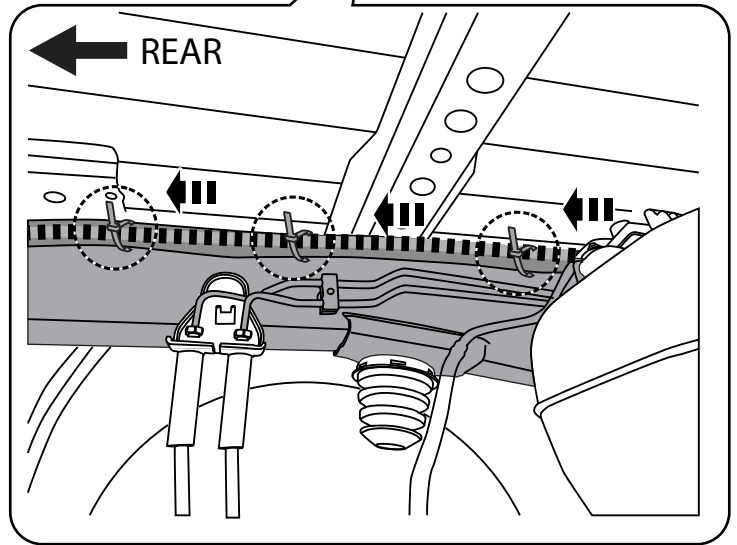
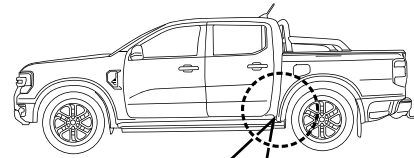
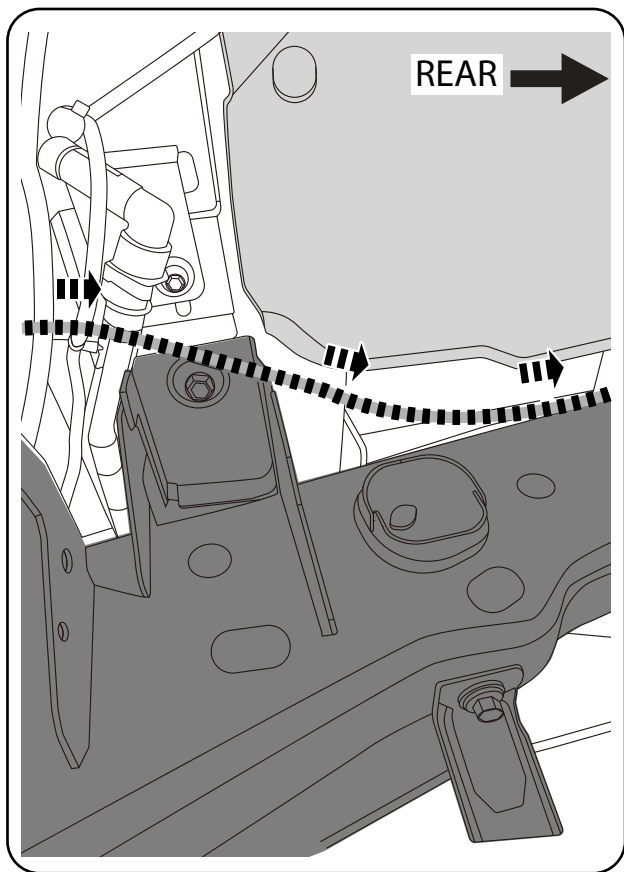

7 Push the remaining harness over to the **chassis rail inner** and continue running it towards the rear of the vehicle. Secure with 3 Cable Ties as shown.

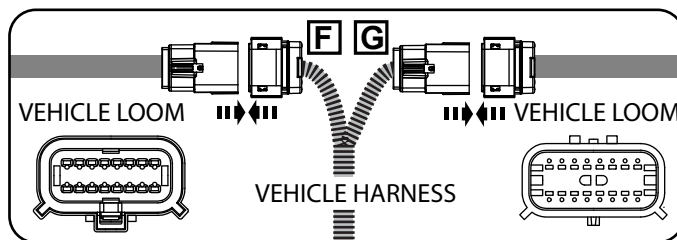
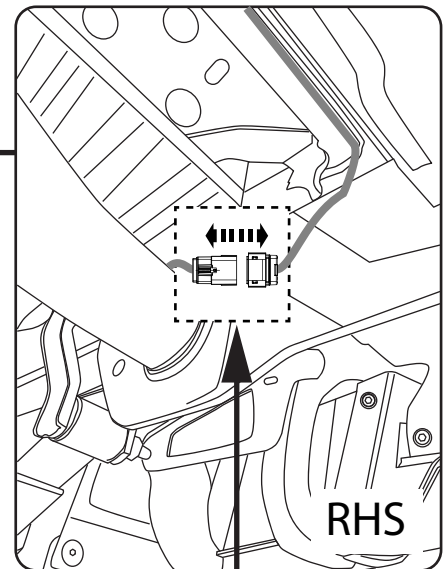
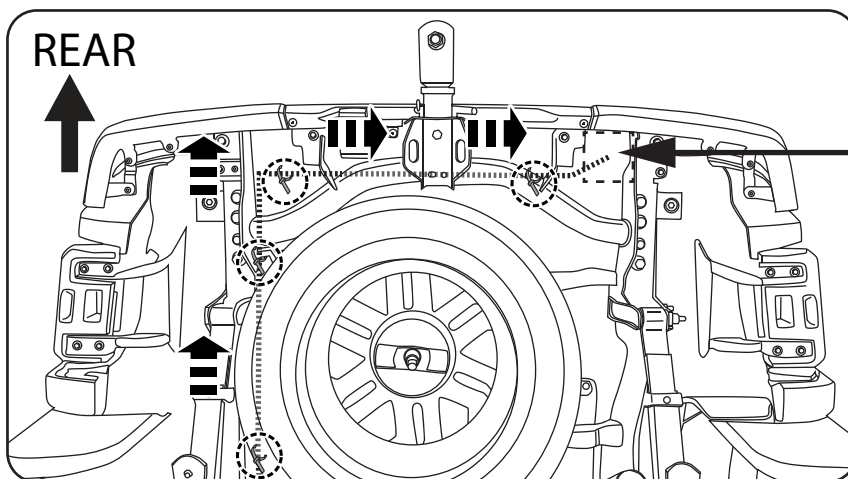

8 Run the vehicle harness along the **inner chassis rail** aide and along the tail end of the vehicle till reaching the loom connectors on as shown. Using cable ties, secure the vehicle harness to the vehicle tub in 4 locations as shown . Disconnect the 16 pin vehicle loom connectors and patch it using the vehicle harness connectors **F & G**.

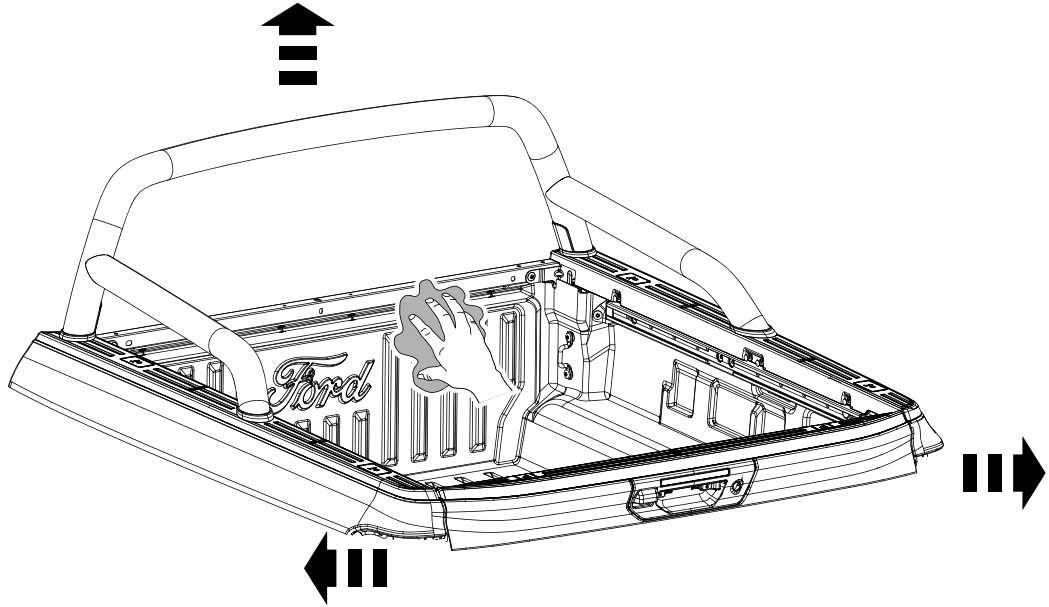
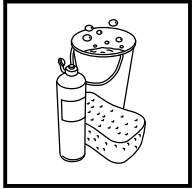

1 If Sportsbar is present, remove it and store in safe place. Keep brackets attached to the tub. Clean the top and inside of the tub. Remove the tail lights.



PERFORM THIS STEP ONLY IF CMS IS FITTED

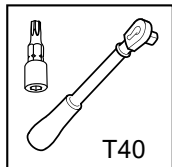

T40

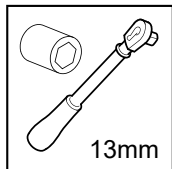

13mm

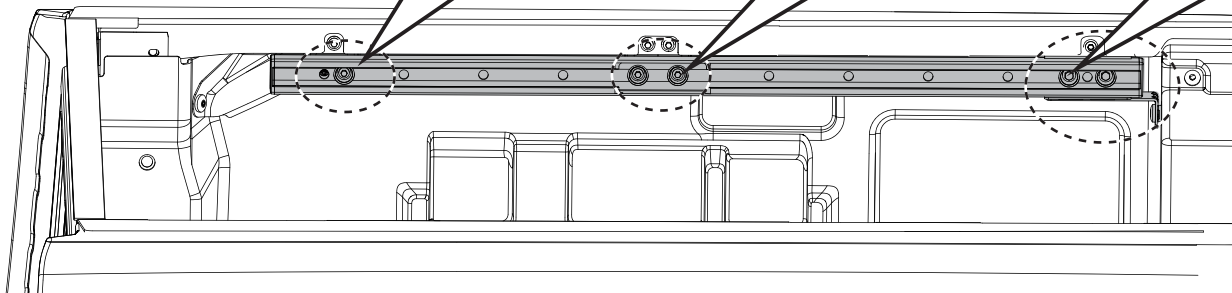
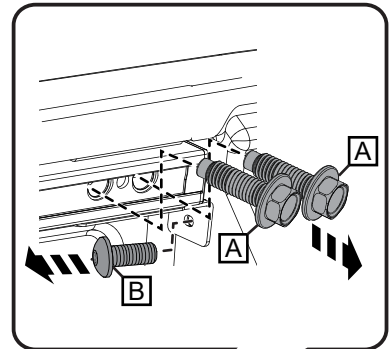
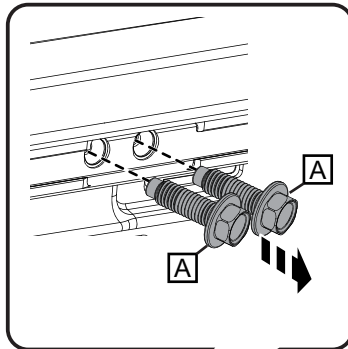
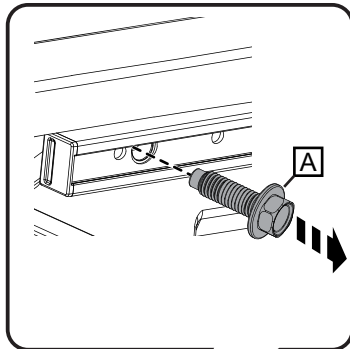

RHS SHOWN

2 If CMS rail is present, remove and retain CMS rail, hex head screws (A) and torx screw (B). If CMS rail is not present, remove torx screw (B) located at the rear of the tub. Retain the CMS bar and hardware for refit.



FRONT DRAIN TUBES - TUB DRILLING WITH TUBLINER

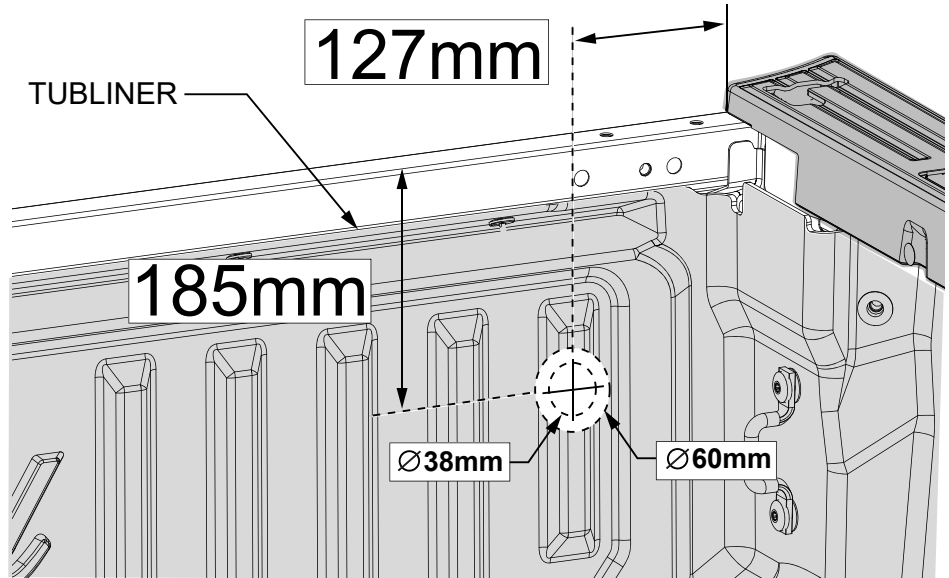
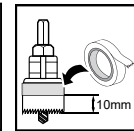
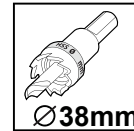
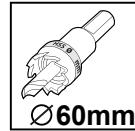
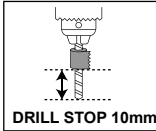
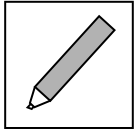
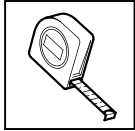

FRONT OF TUB - RHS

- 3** On the tub front panel, measure and mark up the positions for the front drain tubes. Centre punch the locations and drill 5.5mm pilot hole through the **tub and tubliner**. Using hole saw drill **60mm hole in the tubliner only**, use 10mm stop. With a **38mm hole saw**, drill hole in the **tub** following the pilot hole. Deburr both holes and apply rust inhibitor to the metal. Repeat for LHS.



FRONT DRAIN TUBES - TUB DRILLING (NO TUBLINER)

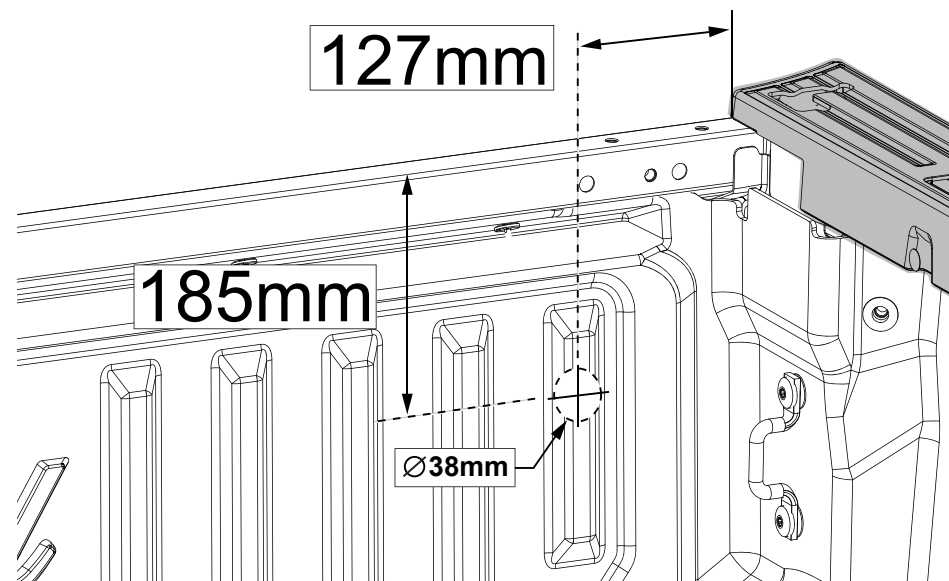
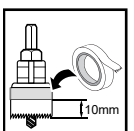
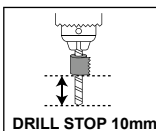
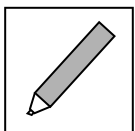
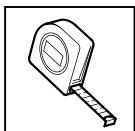

FRONT OF TUB - RHS

- 4** On the tub front panel, measure and mark up the positions for the front drain tubes. Centre punch the locations and drill 5.5mm pilot hole through the **tub**. Using hole saw drill **60mm hole in the tubliner only**, With a **38mm hole saw**, drill hole in the **tub** following the pilot hole use 10mm stop. Deburr both holes and apply rust inhibitor to the metal. Repeat for LHS.



EGR ROLLTRAC SPECIFIC DDK'S ARE AVAILABLE FROM YOUR DEALER.
 IF A DDK IS TO BE INSTALLED, IT SHOULD BE FITTED AFTER INSTALLING EGR ROLLTRAC.
 NOTE THAT IF DDK IS TO BE INSTALLED, DRILLING AT REAR OF TUB IS NOT REQUIRED.



REAR DRAIN TUBES - TUBLINER FITTED (NO DDK)
STEP 5 & 6

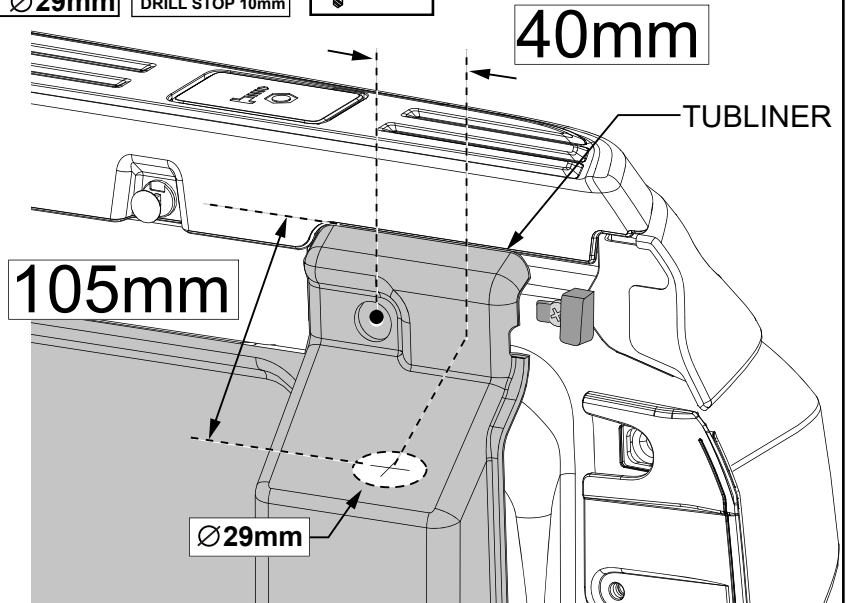
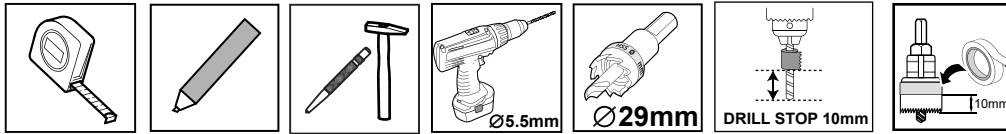

REAR OF TUB - RHS

- 5** On the tub rear panel, measure and mark up the positions for the rear drain tubes. Centre punch the locations and drill 5.5mm pilot hole through the **tubliner ONLY!** Using hole saw drill 29mm hole in the **tubliner**. Use 10mm stop. Repeat for LHS.

SECTION VIEW

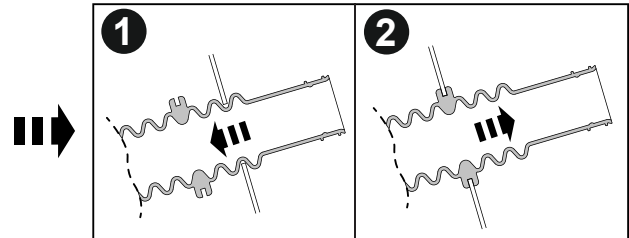
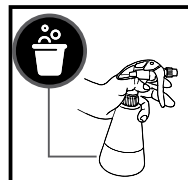
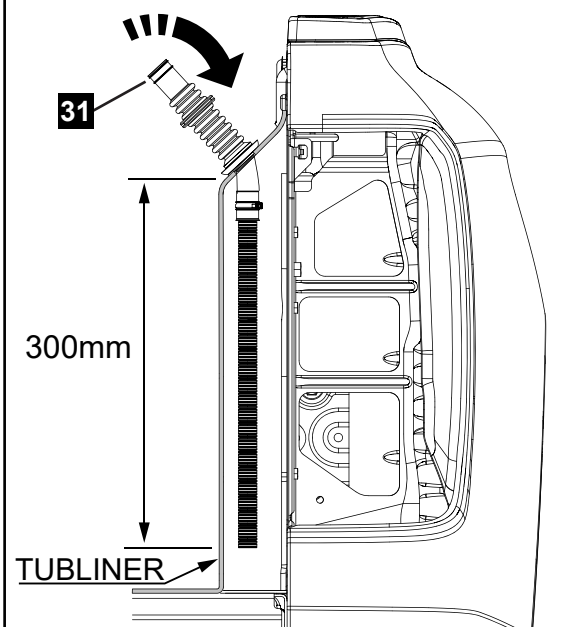

RHS & LHS

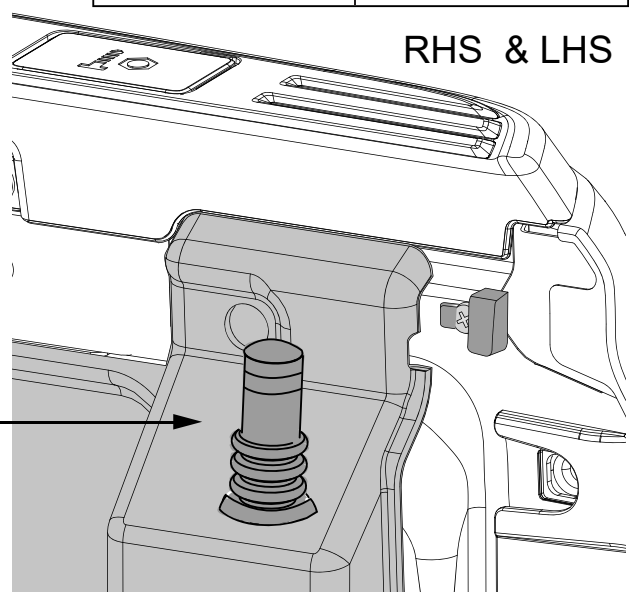

- 6** Trim the drain tube conduit as shown and fit from the outside of the tubliner in through the drilled hole. Spray tubes with soapy water to help with fitment. Repeat for LHS.



REAR DRAIN TUBES - TUB DRILLING (NO TUBLINER & NO DDK) STEP 7 & 8

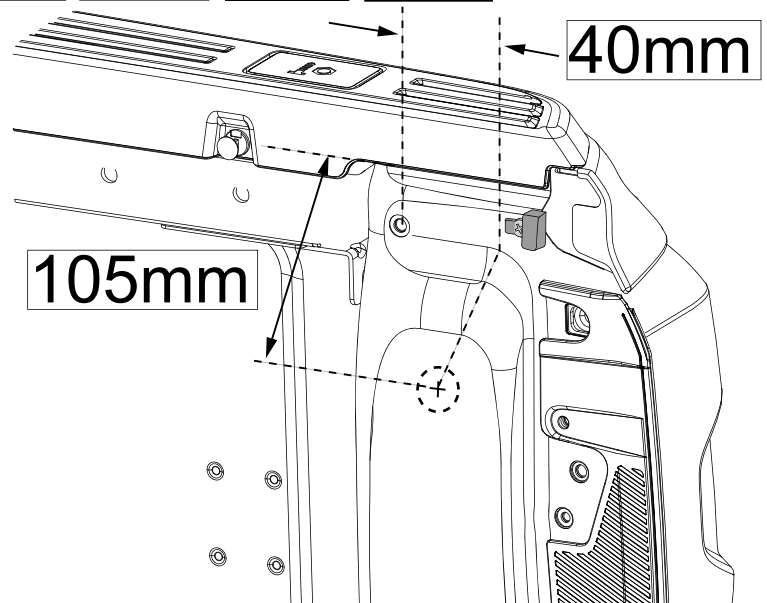
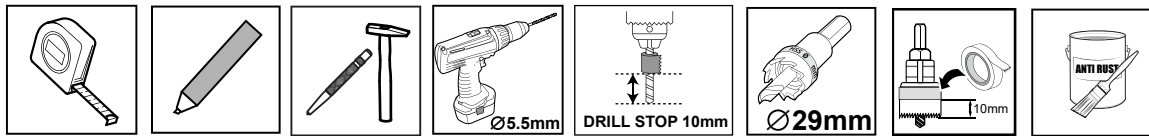

REAR OF TUB - RHS

- 7** On the tub rear panel, measure and mark up the positions for the rear drain tubes. Centre punch the locations and drill 5.5mm pilot hole through the **tub**. Using hole saw drill 29mm hole in the **tub**. Use 10mm stop. Repeat for LHS.

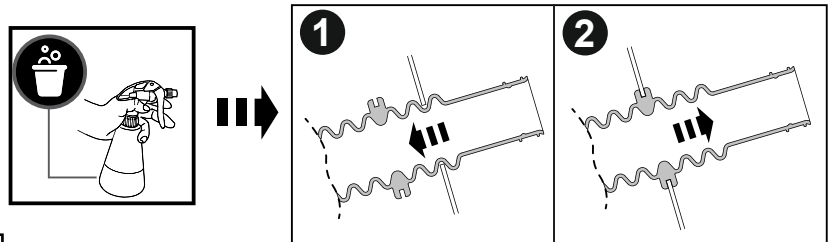

RHS & LHS

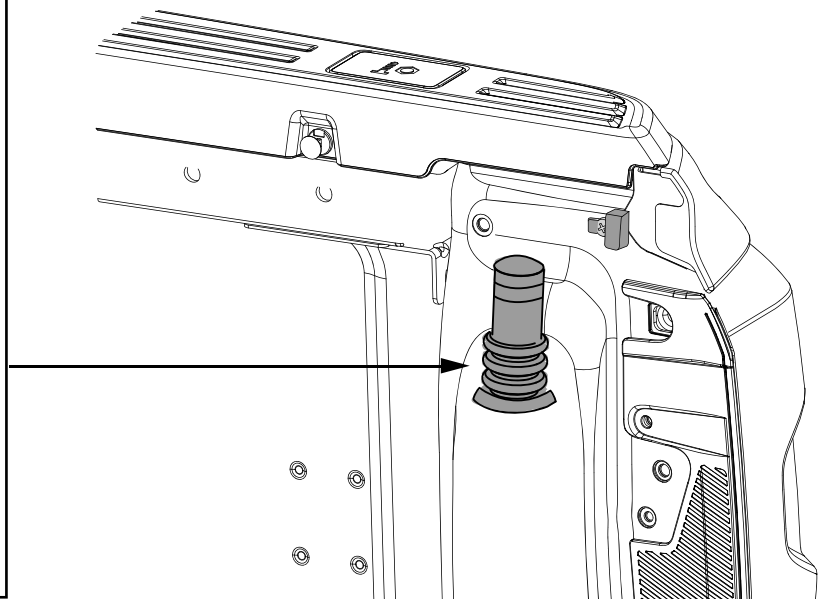
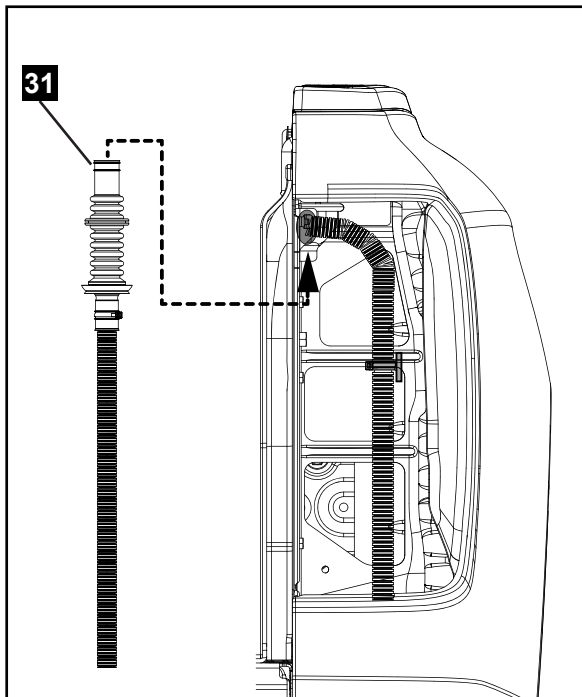

- 8** Fit the rear drain tubes from the inside of the tail lamp cavity up through the drilled hole. Spray tubes with soapy water to help with fitment. Repeat for LHS.

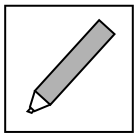
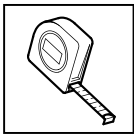

Cutting device
needed to trim
bed cap

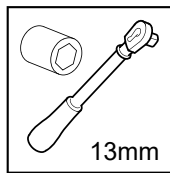

13mm

BED CAP - RHS

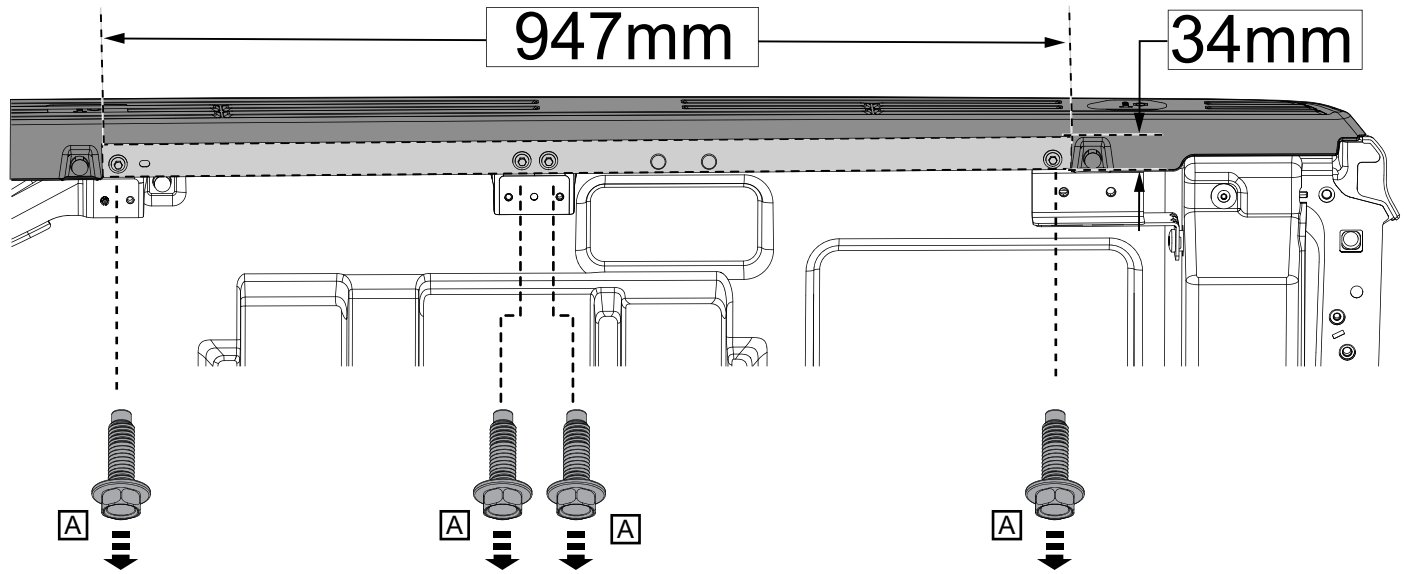

- 9** Inside the tub locate the RHS bed cap and cover the inside face with masking tape to allow marking with pen and avoid scratching during trimming. Mark the bed cap as shown above and trim the area using suitable tool. If CMS rail fitted, remove the 4 M6 screws as shown. Repeat for LHS.

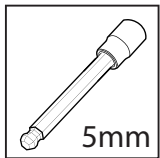

5mm

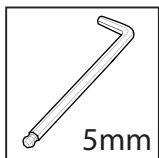

5mm

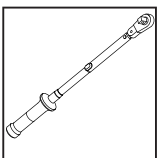

NOT SUPPLIED

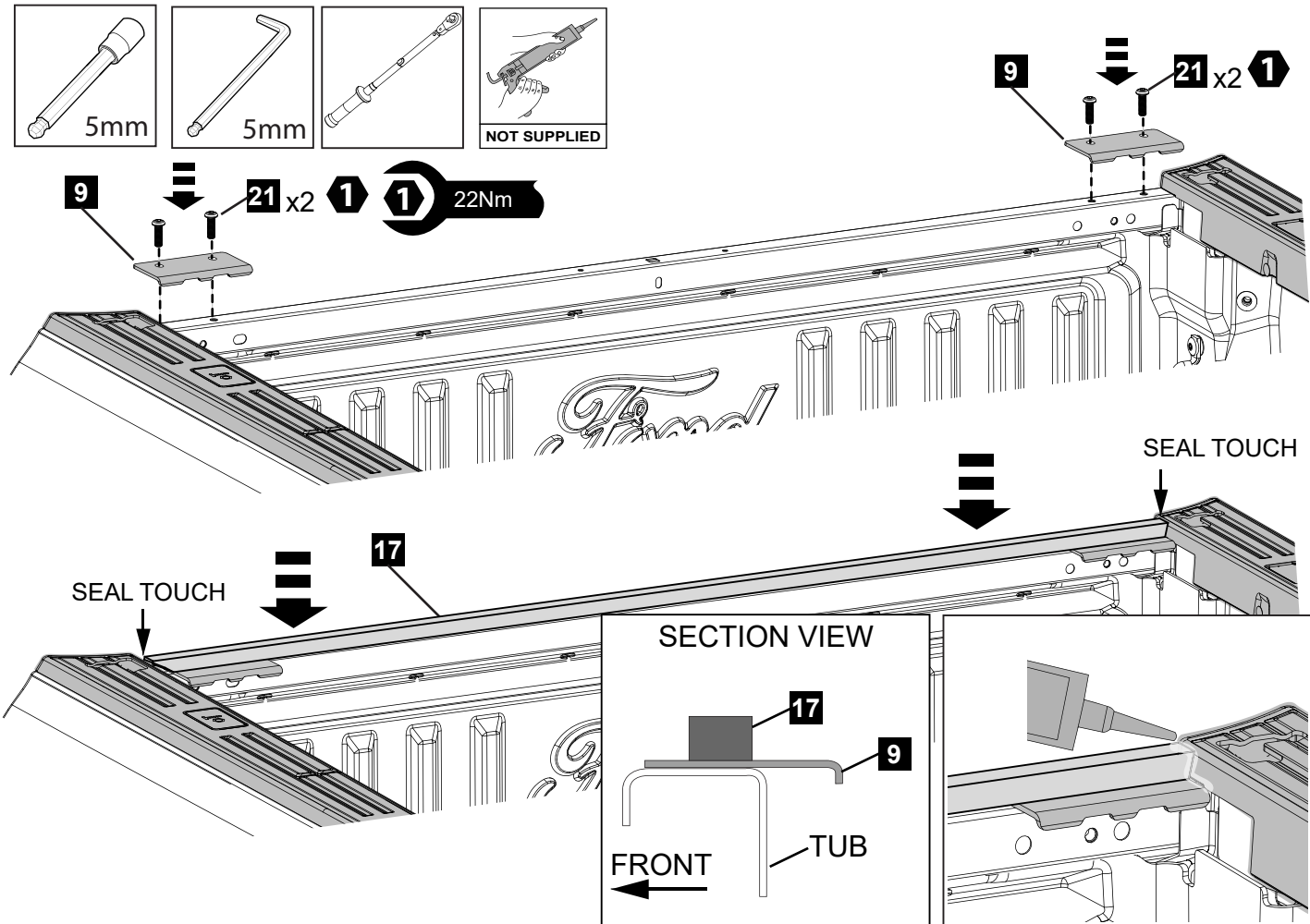

- 10** Fit the two h-bar corner brackets (9) to the top of the front of the tub and secure with two screws (21). Repeat for the LHS. Apply the front rail seal (17) along the top of the h-bar as shown and ensure ends touch the endcap. Apply Silicone in the gap between the rail seal, bracket and tub rail as shown. NOTE: Seal all holes in the tub as required.

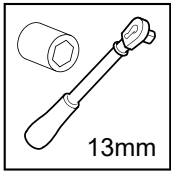

MNT BAR - RHS

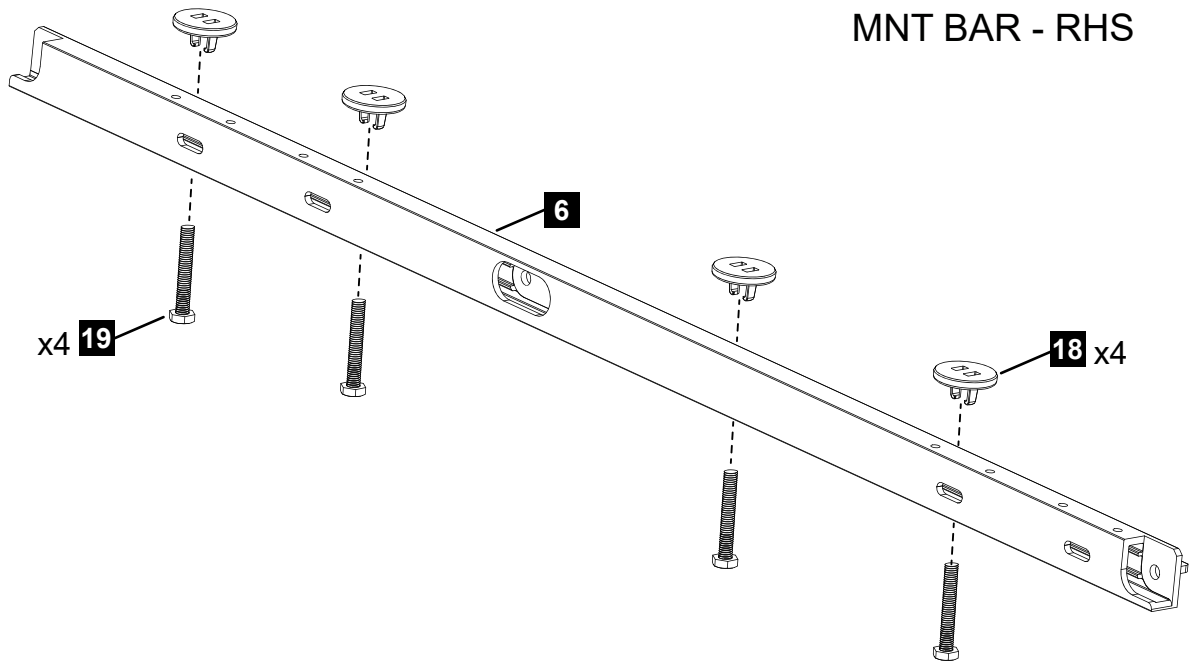

MNT BAR - LHS

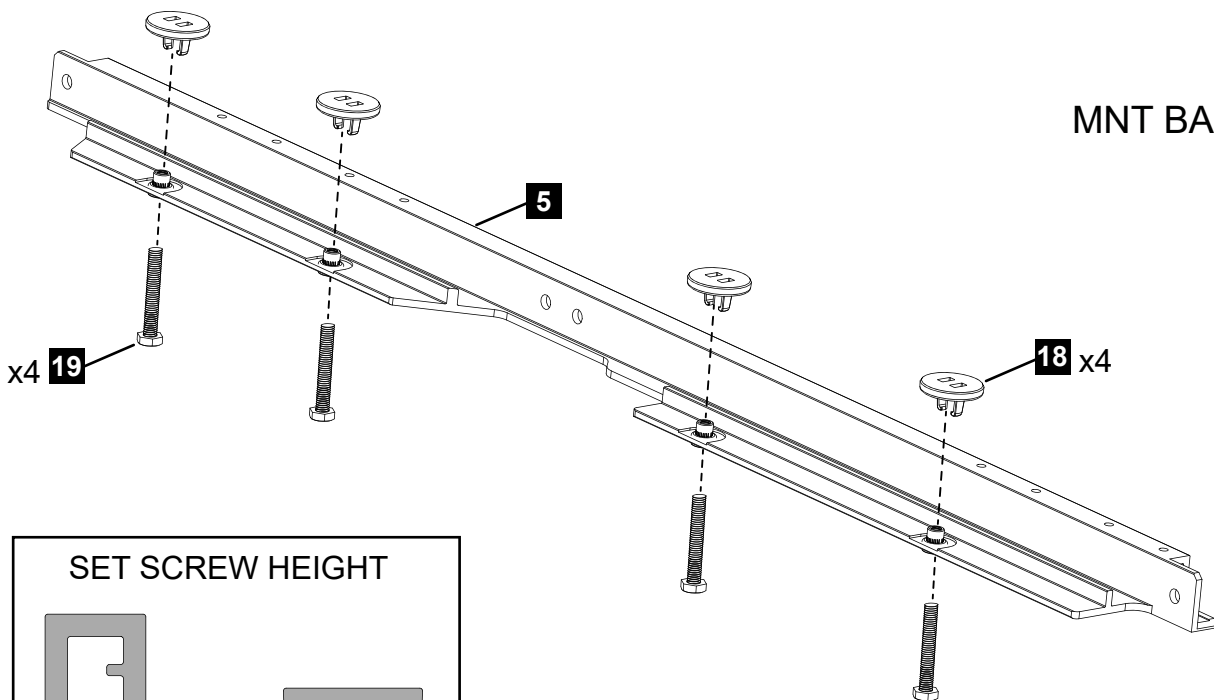

SET SCREW HEIGHT

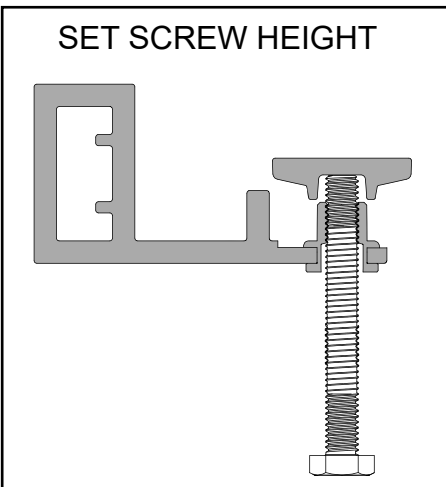

- 11** Fit the 4 screws (19) into the RHS mounting rail (6) and fit the end pads as shown. Set the screws height as shown in detail. Repeat for the LHS mounting rail.
NOTE: Screws will be adjusted in later stage once fitted to the tub.

MNT BAR - RHS

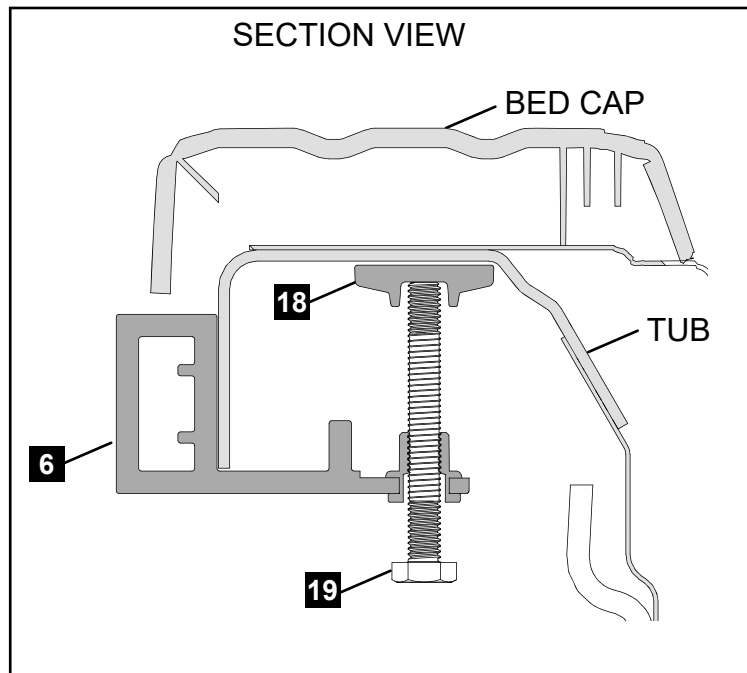
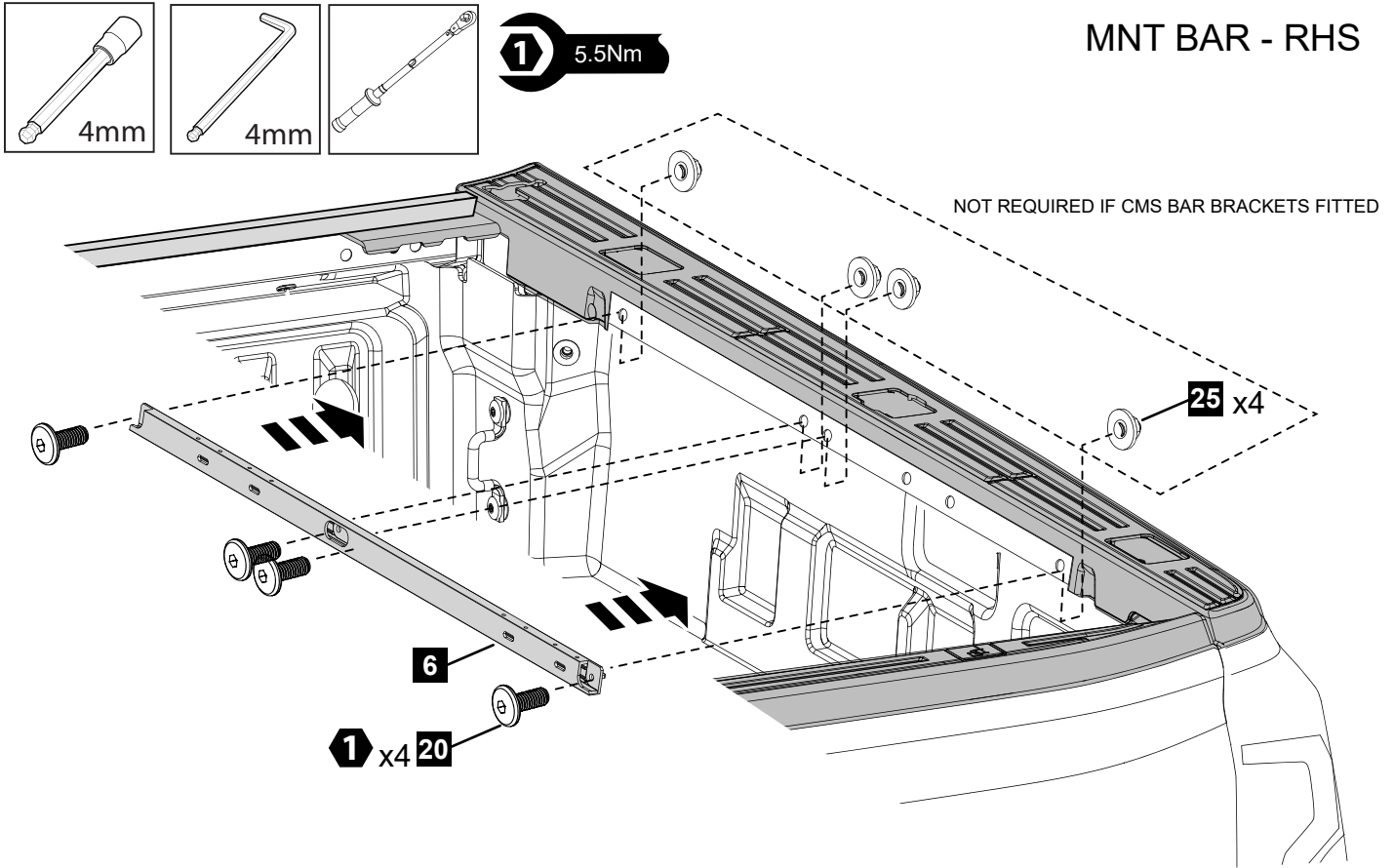

- 12** Fit the RHS mounting bar to the tub as shown. Secure with 4 screws (20) and nuts (25). Torque to 5.5Nm.
 NOTE: Level the bar by pushing it up till it contacts the tub (see section view).
 Turn the screw (19) up until the cap (18) contacts the inner tub sheet metal (see section view). Do not overtighten.

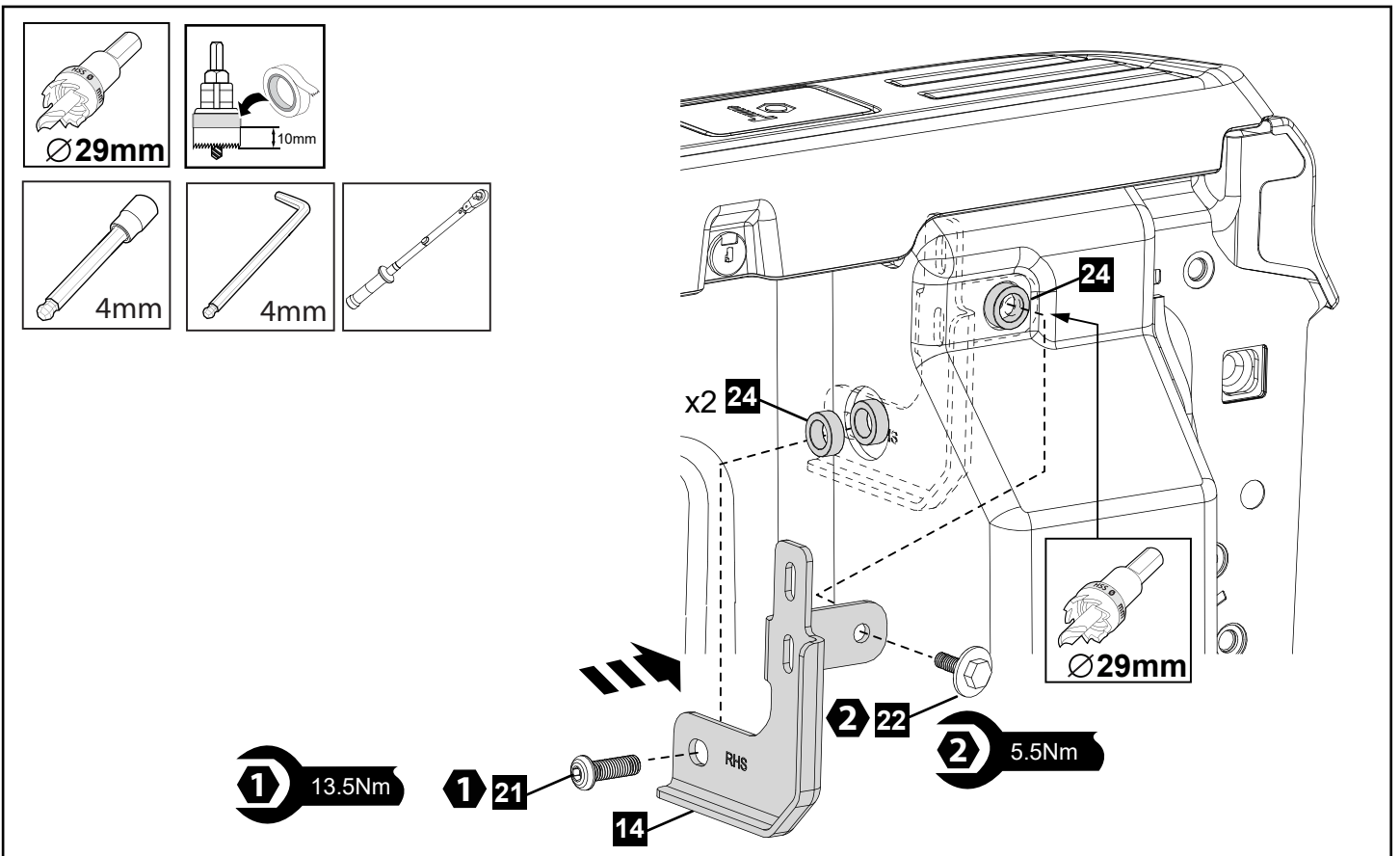

- 13** Fit the RHS rear mounting bracket to the tub and secure with 2 screws (21) and (22) as shown. Use 2x spacers (24) behind the bracket (screw (21) location) and 1x spacer (screw (22) location). Torque to 13.5Nm & 5.5Nm. Repeat for LHS.
 NOTE: Clearance hole may have to be drilled in the tubliner for the spacer (24).

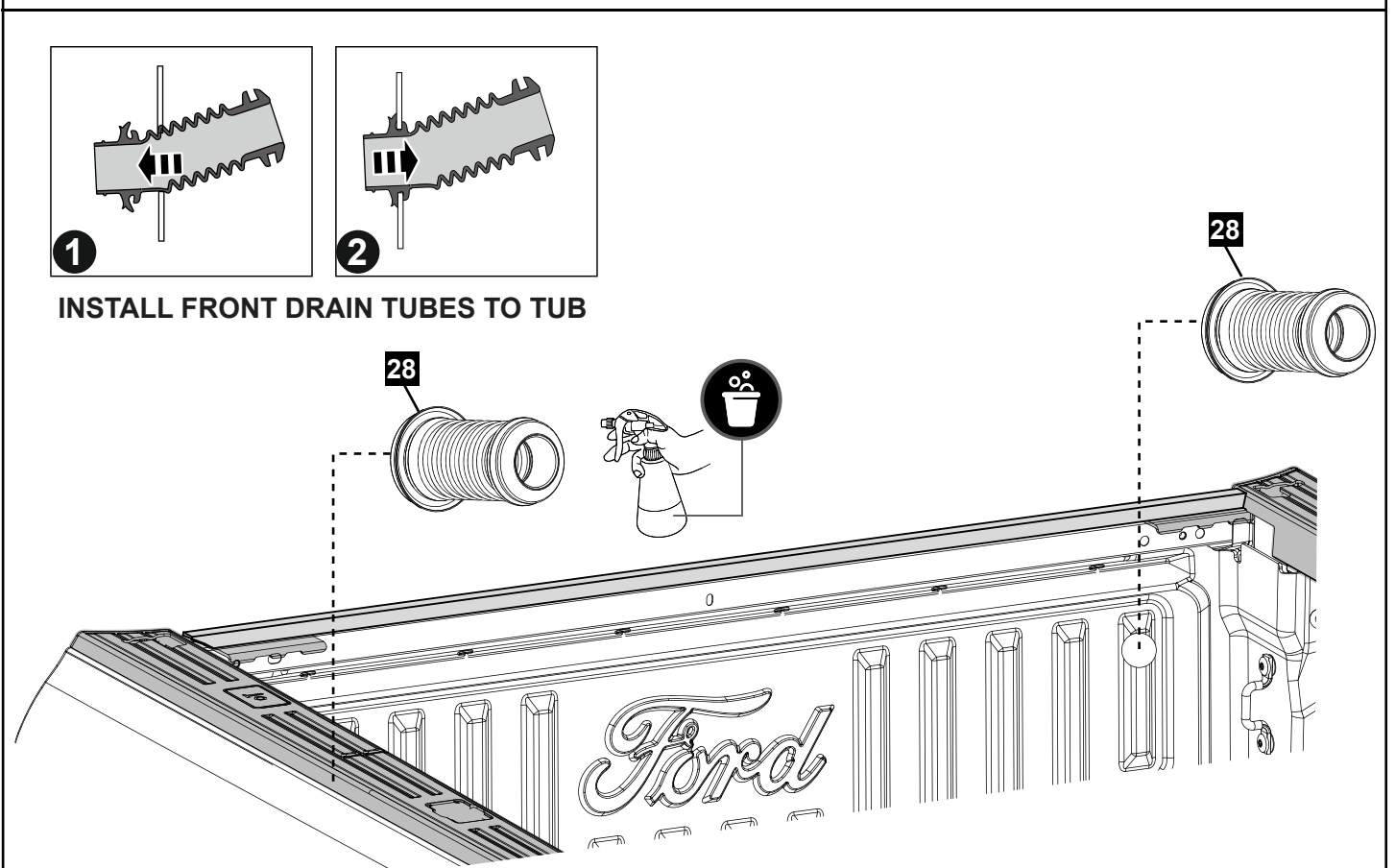

- 14** Connect the front drain tubes (8) to the tub. Make sure that both tubes engage over the wall of the tub. Leakage will occur if they are not properly installed.



DURING ASSEMBLY PROCEDURE SUPPORT AT CENTRE OF CANISTER ONLY, PLACE ON TOP AND BASE CARTON (OR SIMILAR), COVER WITH FOAM BLANKET. TO AVOID SCRATCHING POWDERCOATED SURFACES. DO NOT LOAD ELECTRICAL CONNECTORS OR MOTOR COVER.

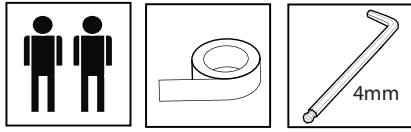

3 **RHS FIT FIRST**

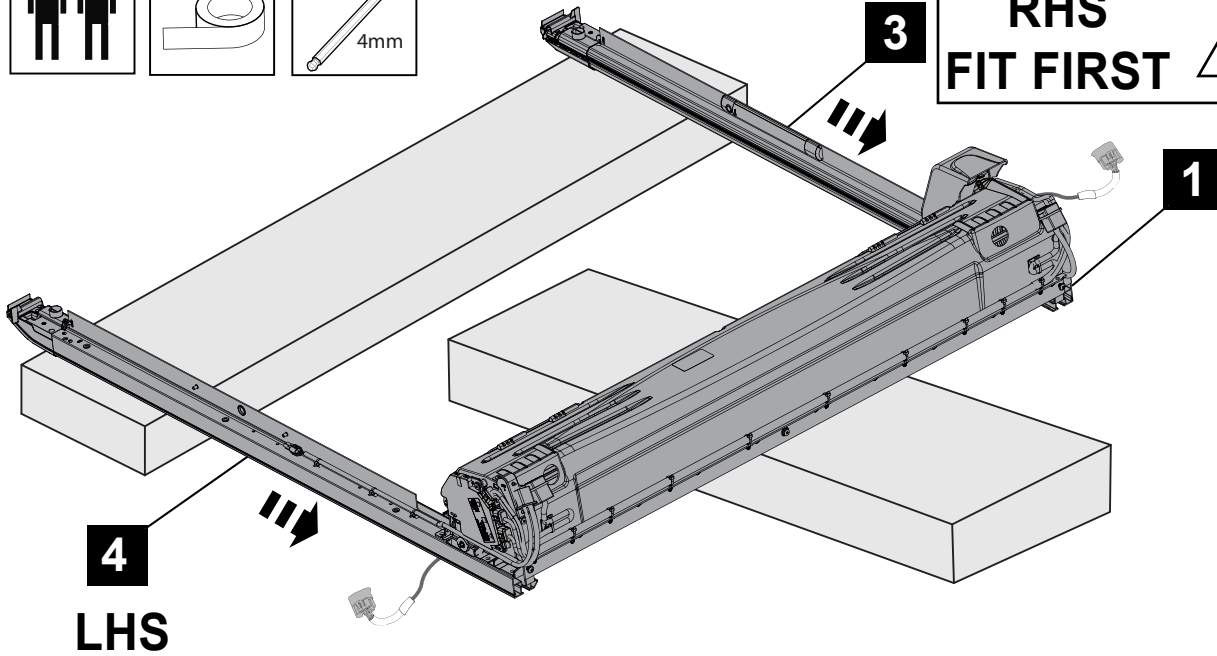

1



ATTENTION: SEAL MUST FACE IN THE DIRECTION AS SHOWN. WARRANTY VOID IF ASSEMBLED INCORRECTLY.

HOLD SEAL FLAT
USE CLOTH TAPE

RHS SHOWN

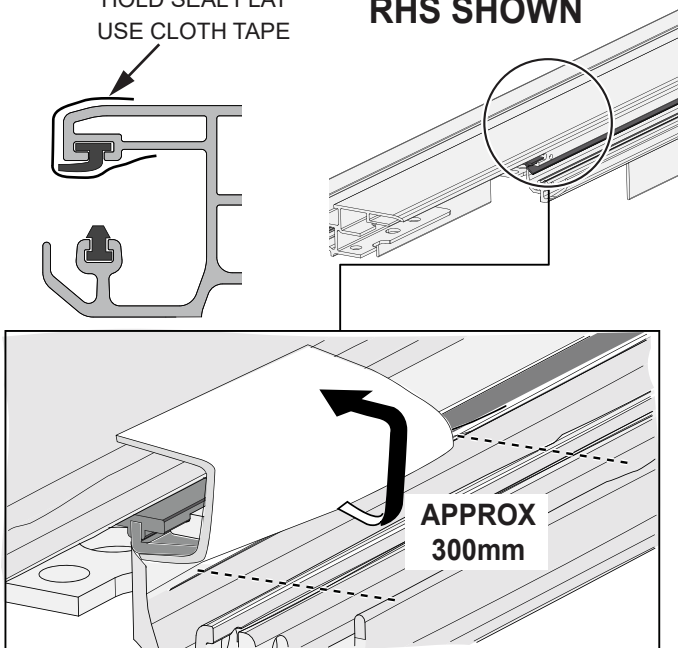

2



ATTENTION: EXPOSE 3 SLATS PRIOR TO FITTING SIDE RAILS.



ENSURE ENDS ARE
ALIGNED & CENTRED

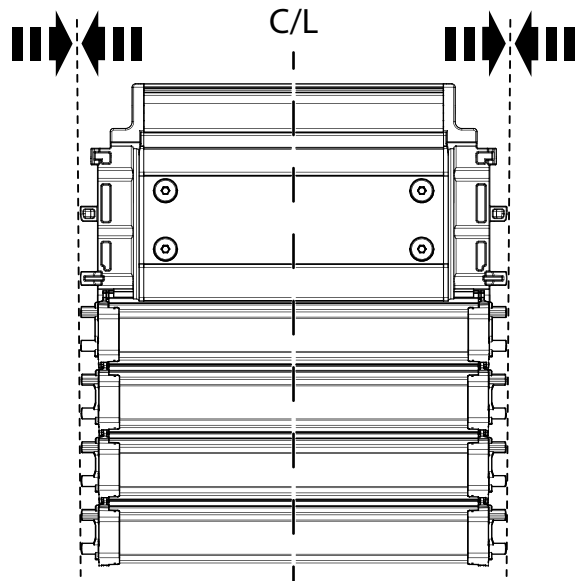

1

Place the canister (1) on two protected boxes as shown, ensure hand rail and slat ends are aligned. Tape up the seal on the Side Rail (3) as shown.

IMPORTANT: Carefully align and slide the rail over the handrail and canister endplate taking particular care to ensure that the siderails are slid straight and no undue force is applied to the rail. Details in following steps.

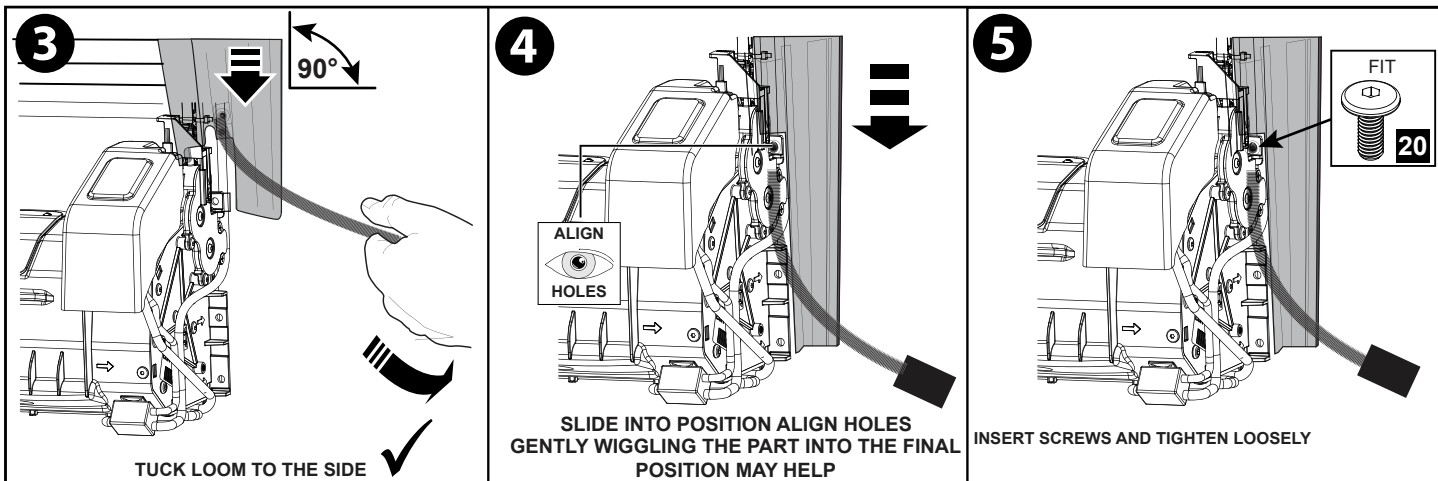

2 Pull hand rail to expose 3 slats. Slide the side rail over slat ends and onto endcap location pins. Align the holes and secure loosely with a M6x15mm screw (20). Do not tighten. Repeat for LHS Rail.

! DURING ASSEMBLY PROCEDURE SUPPORT AT CENTRE OF CANISTER ONLY, PLACE ON TOP AND BASE CARTON (OR SIMILAR), COVER WITH FOAM BLANKET. TO AVOID SCRATCHING POWDERCOATED SURFACES. DO NOT LOAD ELECTRICAL CONNECTORS OR MOTOR COVER. !

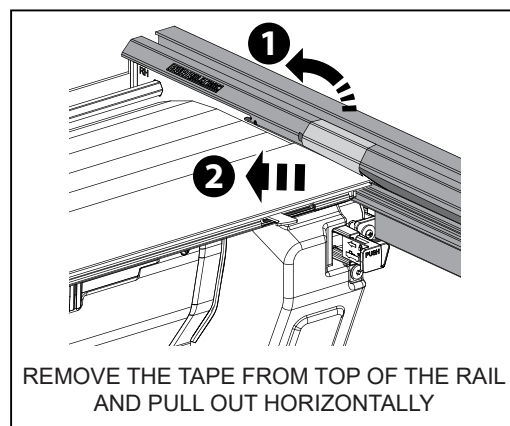
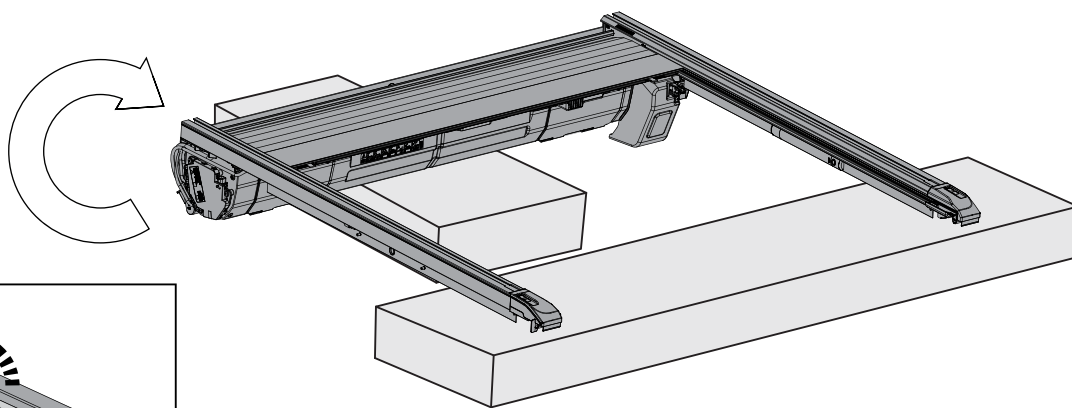

! ATTENTION: SEAL MUST FACE IN THE DIRECTION AS SHOWN. WARRANTY VOID IF ASSEMBLED INCORRECTLY.

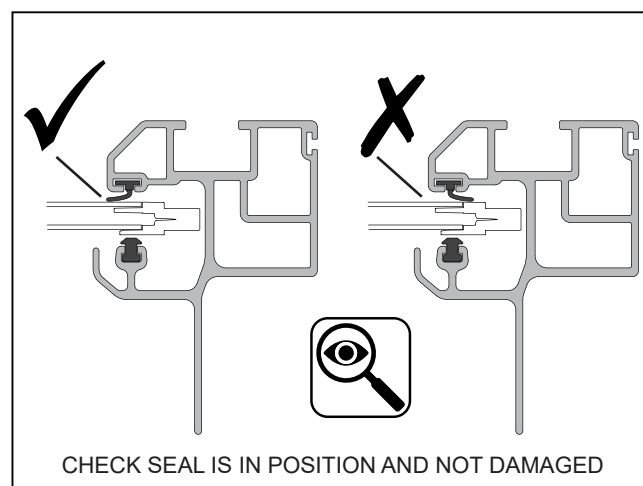
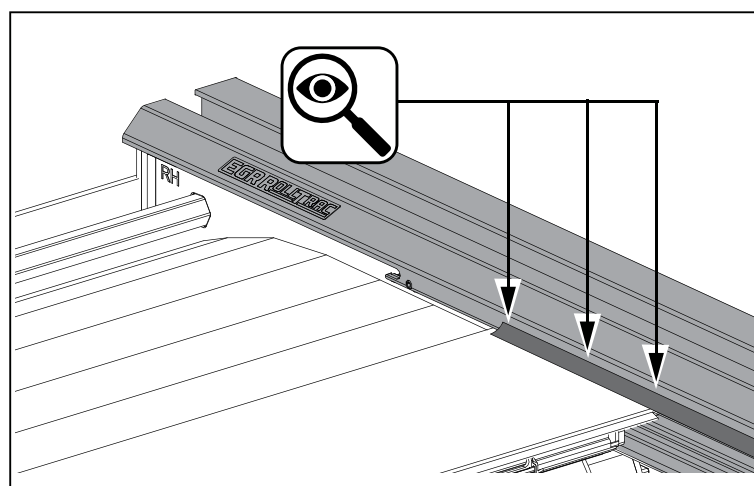

3 Carefully lay the assembly over onto a protected surface. Remove the tape holding the rubber seal and check the seal position as shown.

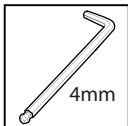

SIDE VIEW

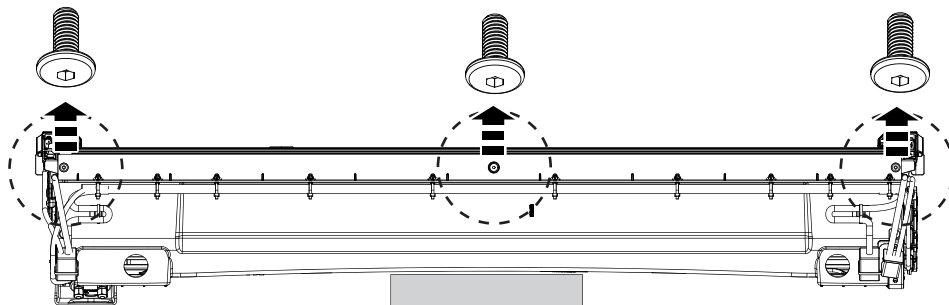
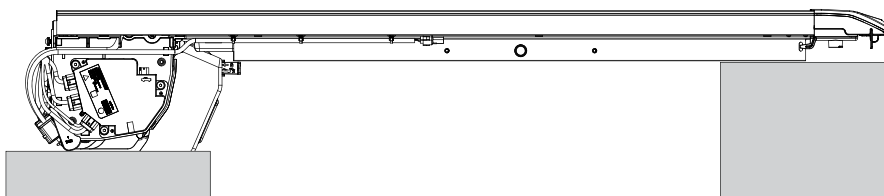

REAR VIEW

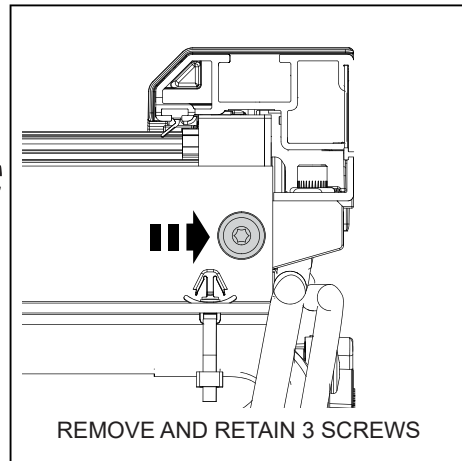

- 4** Remove and retain the 3 pre-fitted screws from the rear of the cover which are used to secure the Front Cover (2) to the assembly. Ensure the product is not scratched or damaged when laying flat.
IMPORTANT: Do not apply load to the electrical connectors and do not sit product on motor cover.

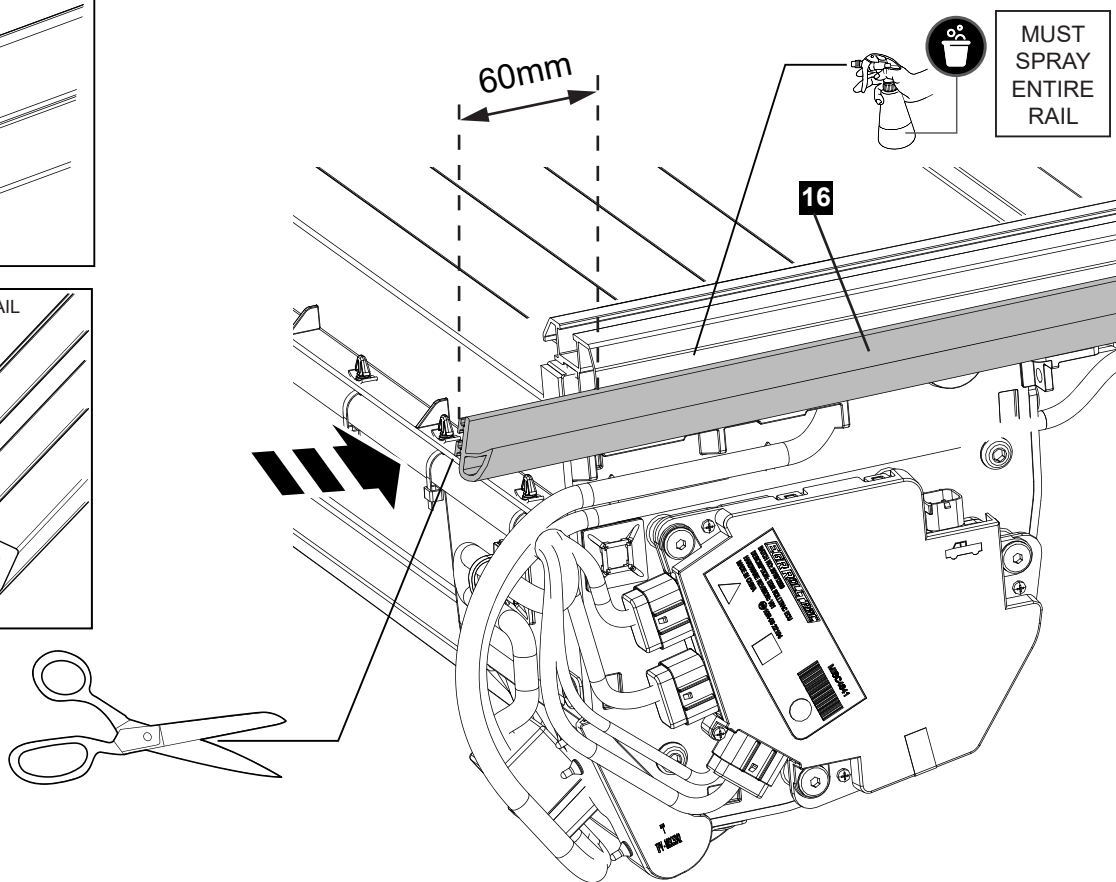
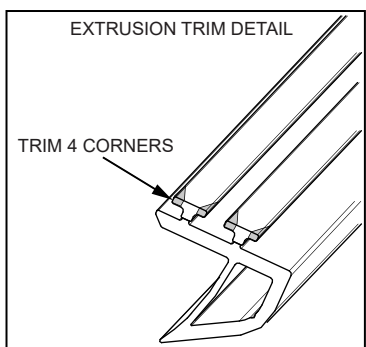
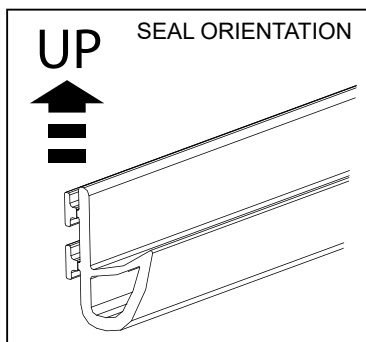

- 5** Spray ENTIRE Side Rail and Seal with soapy water. Slide the side rail seal (16) into the side rail from the front rearwards and trim as illustrated. NOTE: Trim seal backing to aid assembly, see detail.

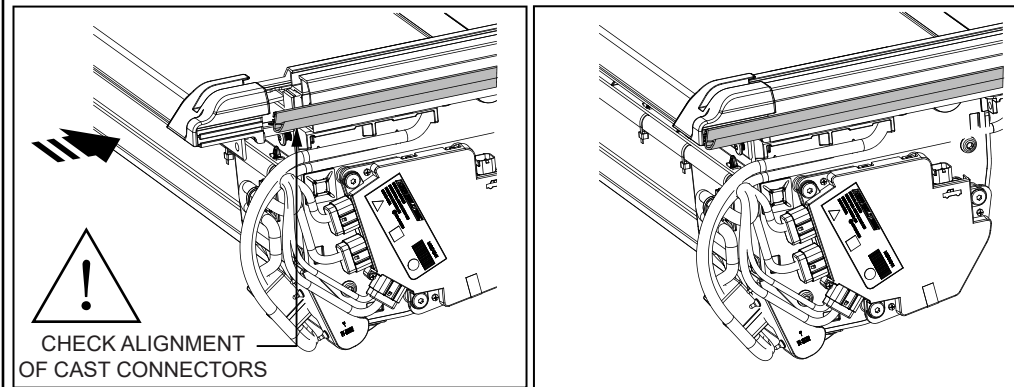
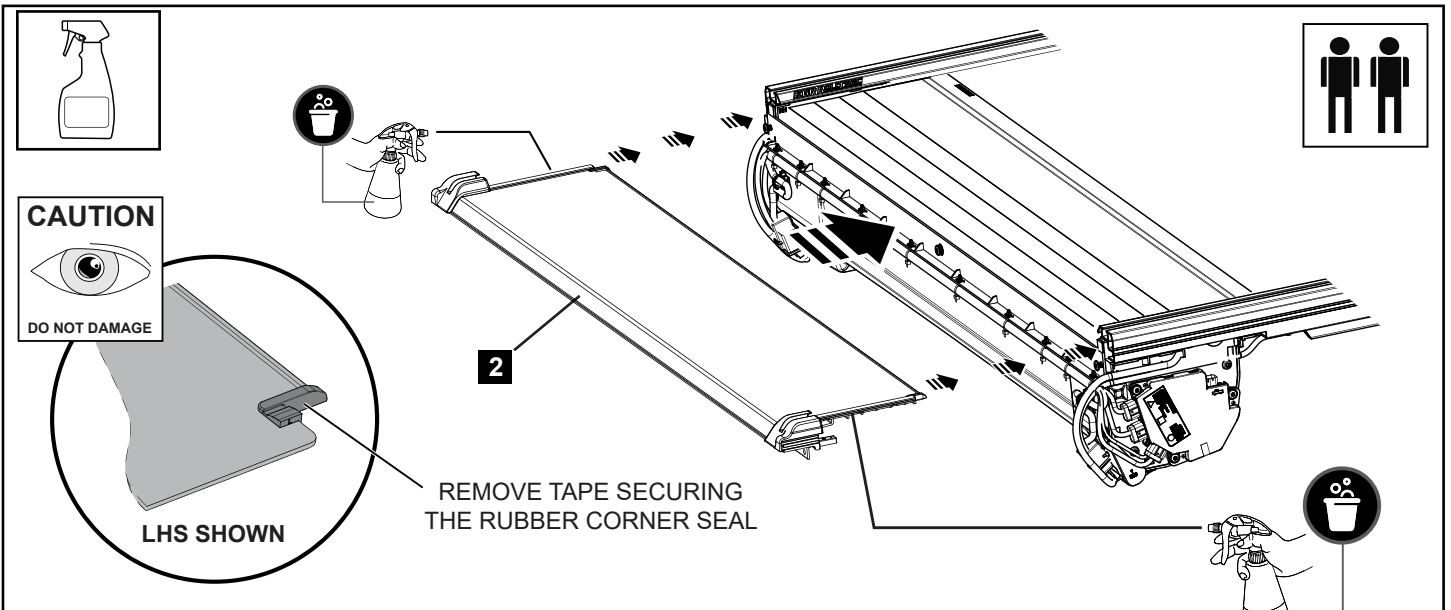

6 Slide the Front Cover (2) over the canister and into the side rail channels.
IMPORTANT: Spray the front cover edge with soapy water to allow it to slide easily into the sides, twisting side rails outwards will also help. You may need to adjust the casting position of the Front Cover (2) to ensure Seals insert smoothly.

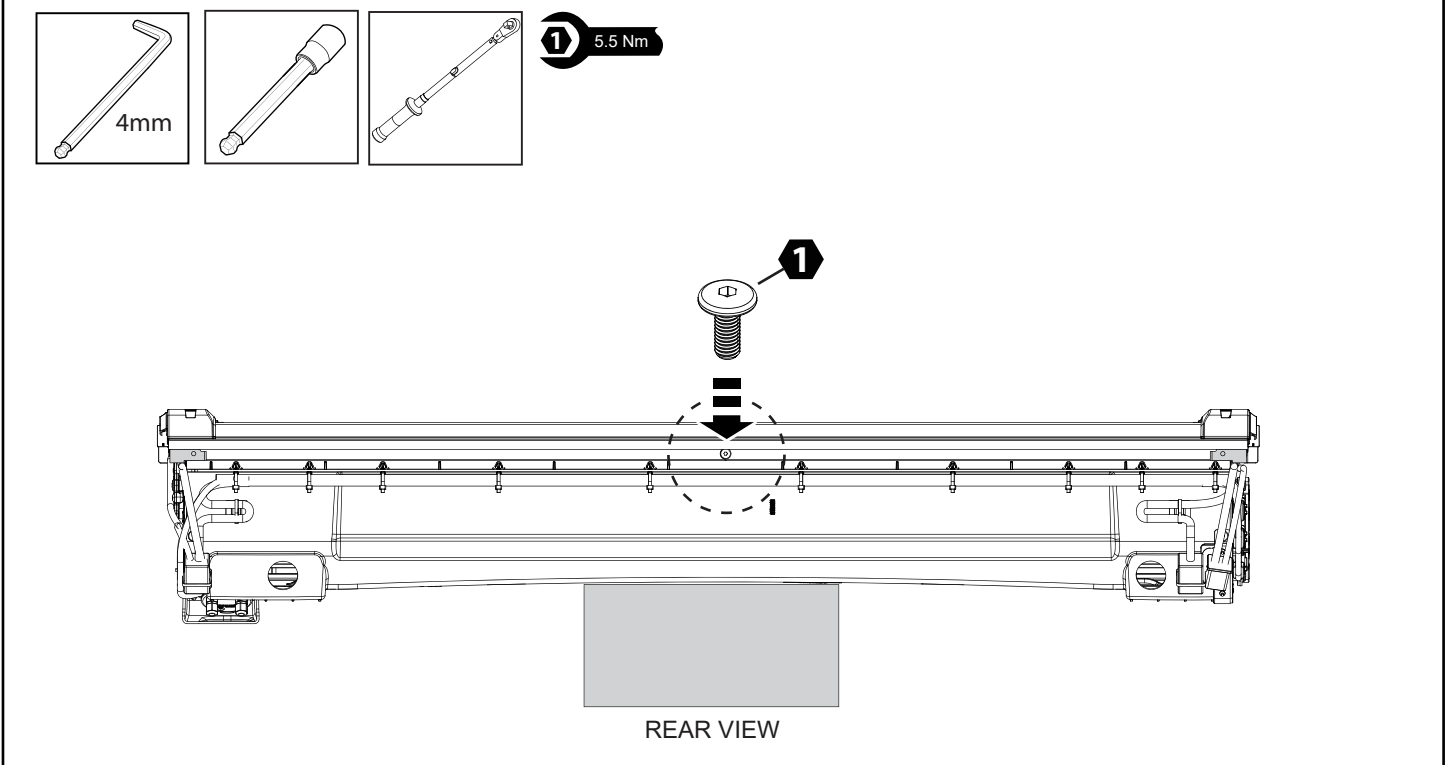

7 Using one screw removed in Step 4, secure the Front Cover (2) to the Canister Assembly (1) as shown and torque to 5.5 Nm.

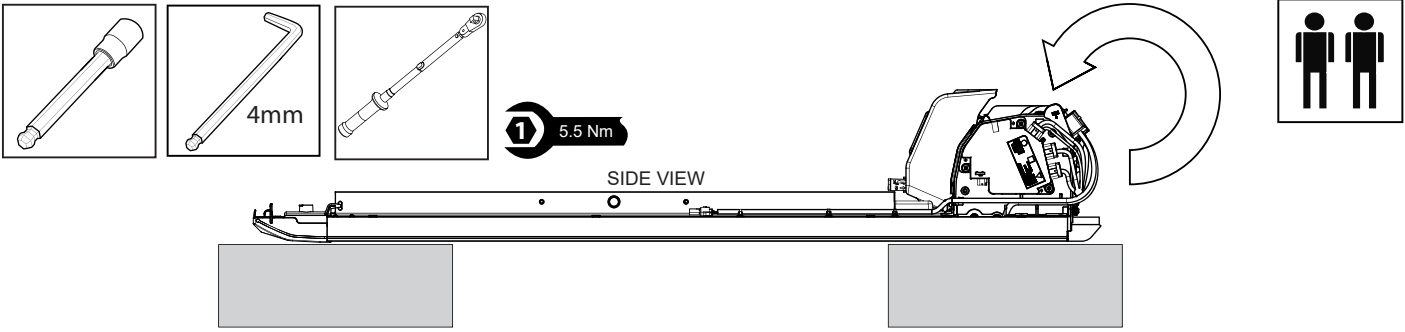

LHS SHOWN - RHS IS A MIRROR IMAGE

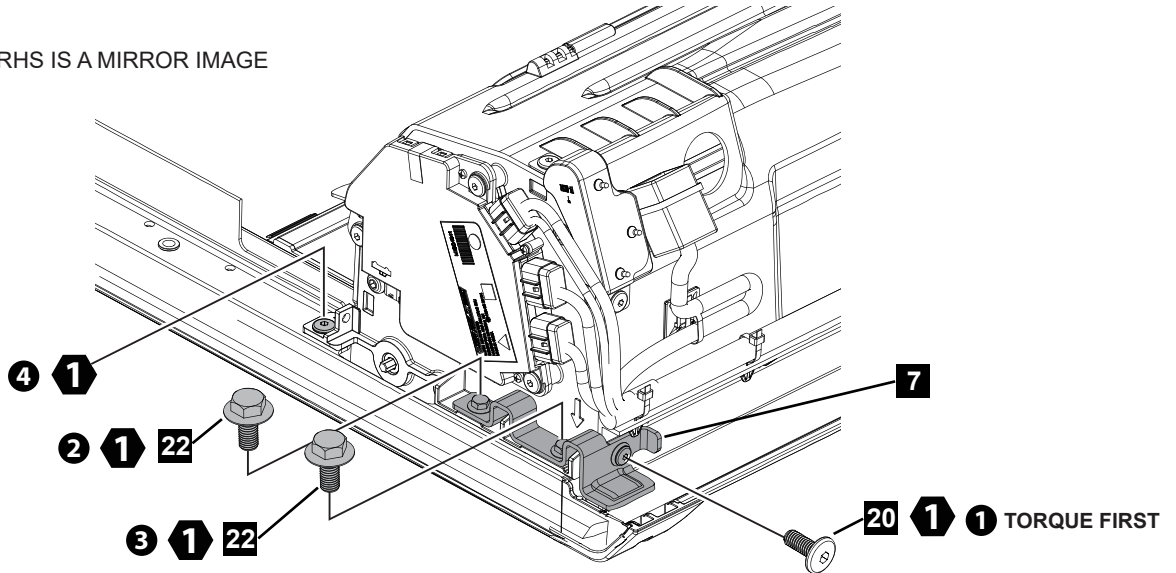

8 Carefully flip the assembly over onto a flat protected surface which will not damage the cover or scratch the paint work. Place the front mounting bracket (7) over the LHS base rail as shown and secure with 2x screws (22) and 1x screw (20) at the front of the Mounting Bracket (7). Torque to 5.5Nm in sequence shown. Repeat for RHS.

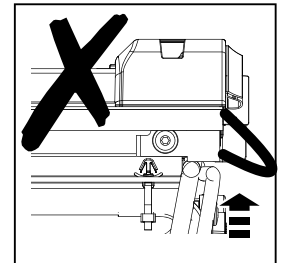

PULL THE CONNECTOR
NOT THE CABLE

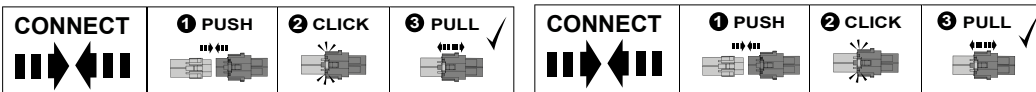

SECURE ALL CABLES TO
PREVENT PINCHING

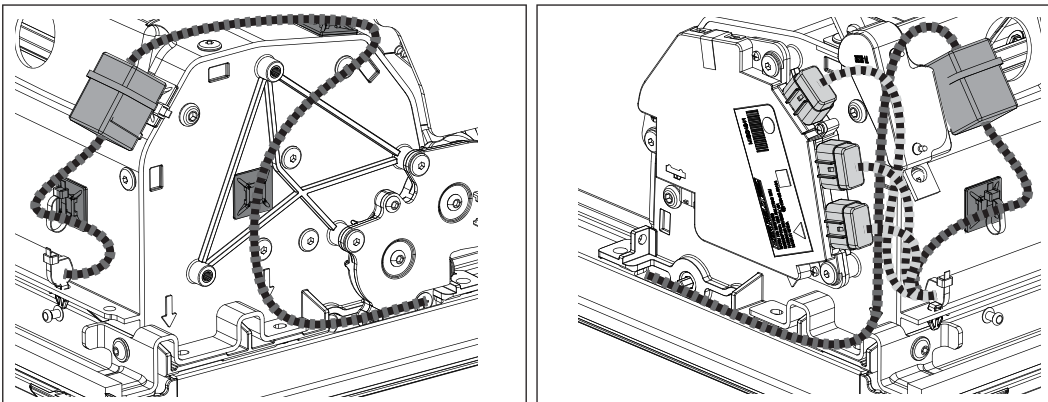

9 Connect side rail harness connectors to the connectors on the canister on the LHS and RHS. Secure the harness to the canister using cable ties at the six locations shown. Secure with zip ties and pads. Ensure all cables are retained to prevent pinching during installation.

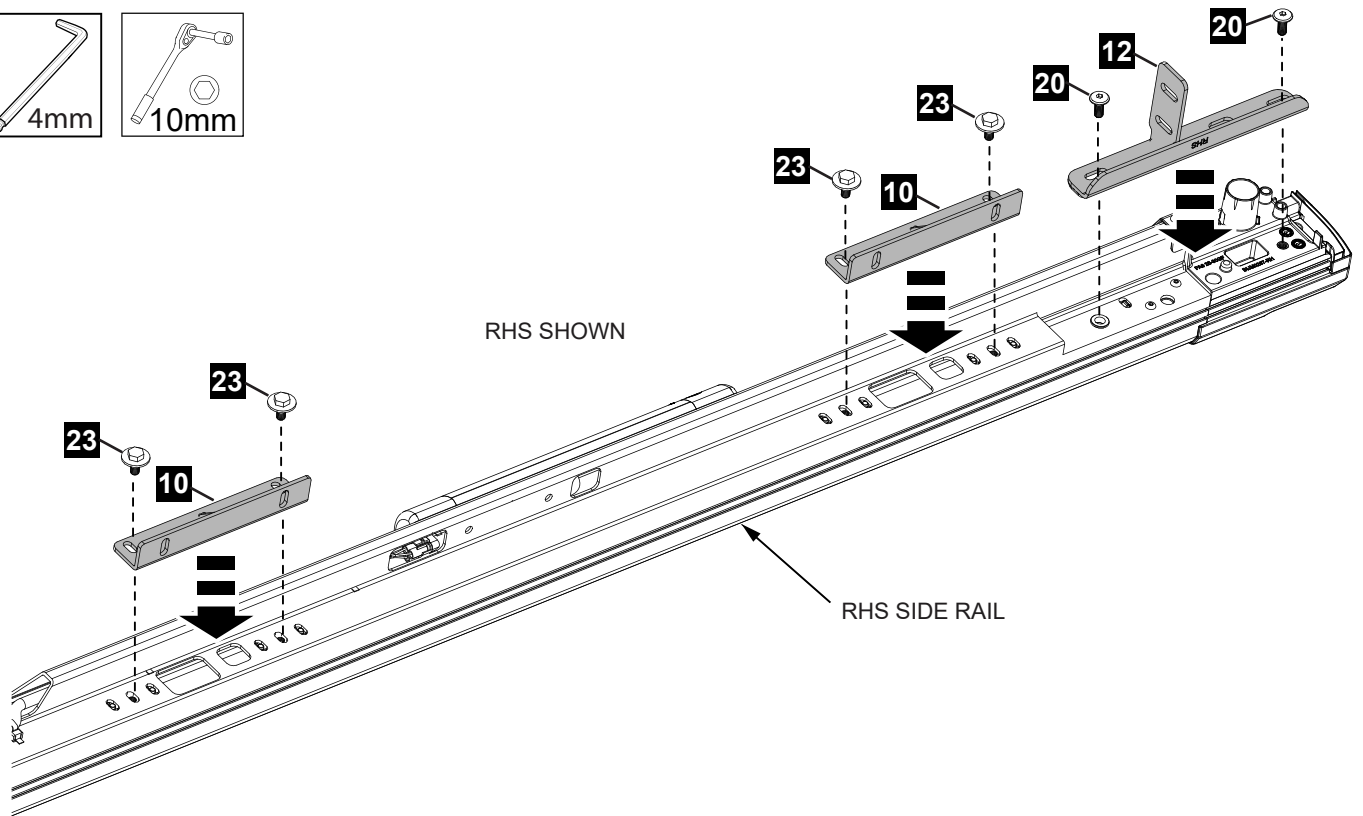
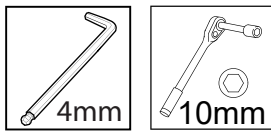

- 10** Install the Rear Mounting Bracket (12) to the RHS Side Rails using 2x screws (20) – tighten loosely at this stage. Install two mounting brackets (10) as shown and secure with screws (23), do not tighten yet.

SETTING BRACE - USER GUIDE

- NOT TO BE USED AS LIFTING DEVICE
- SETTING BRACE SHOULD BE REMOVED ONLY WHEN SET UP IS COMPLETE

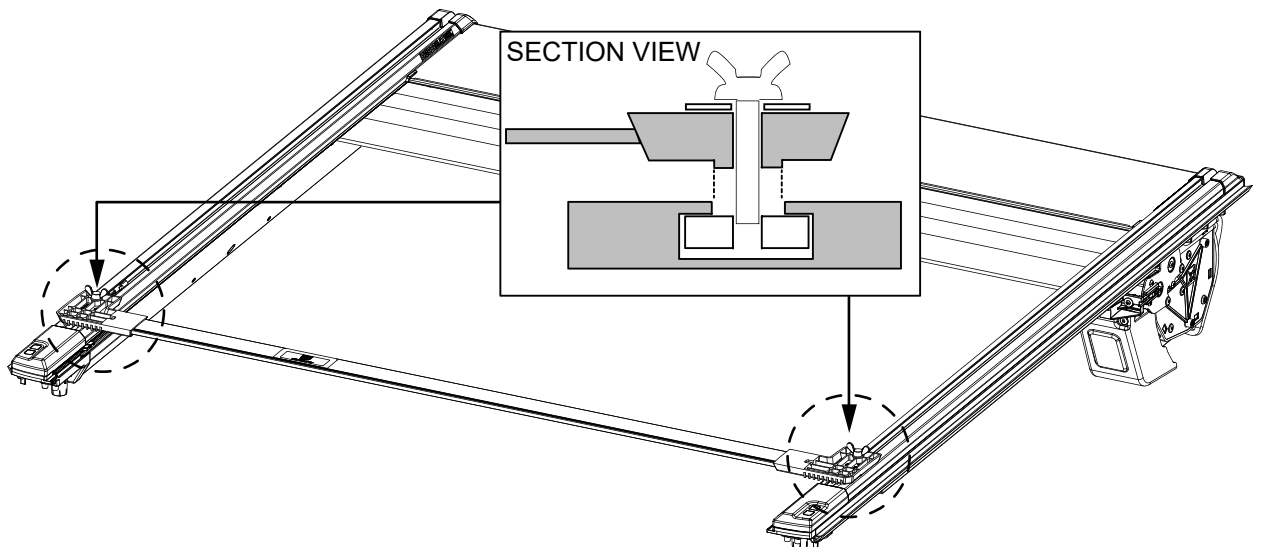
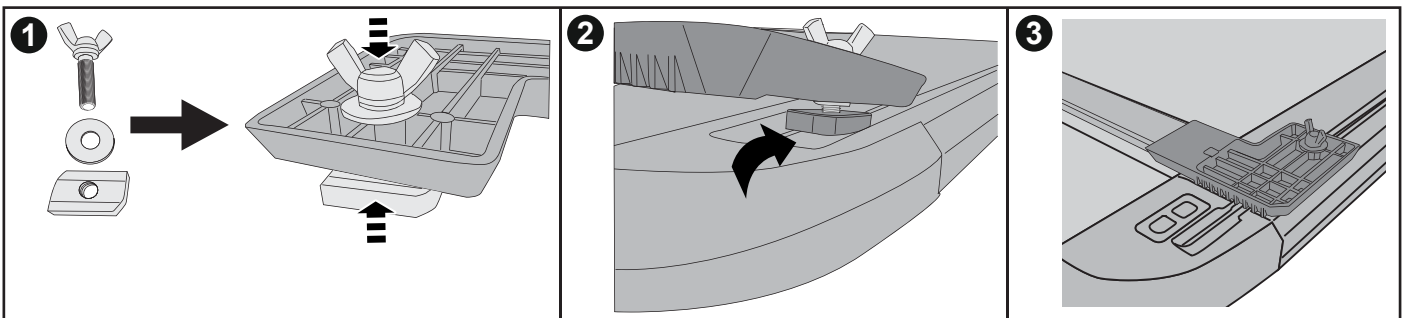

- 11** Setting Brace comes assembled. Fit the taped plates with washers and wing screws as shown to both end's of the Setting Brace. Place the Setting Brace over the rear of the cover and slide the taped plates into the key holes as shown. Once in position, slide the brace backwards till the plastic part of the brace comes to contact with the edge of the rear End cap. NOTE: the brace has 2mm rise at the bottom and it must fit inside the key hole as shown in detail. Tighten the wing bolt (finger tight only).

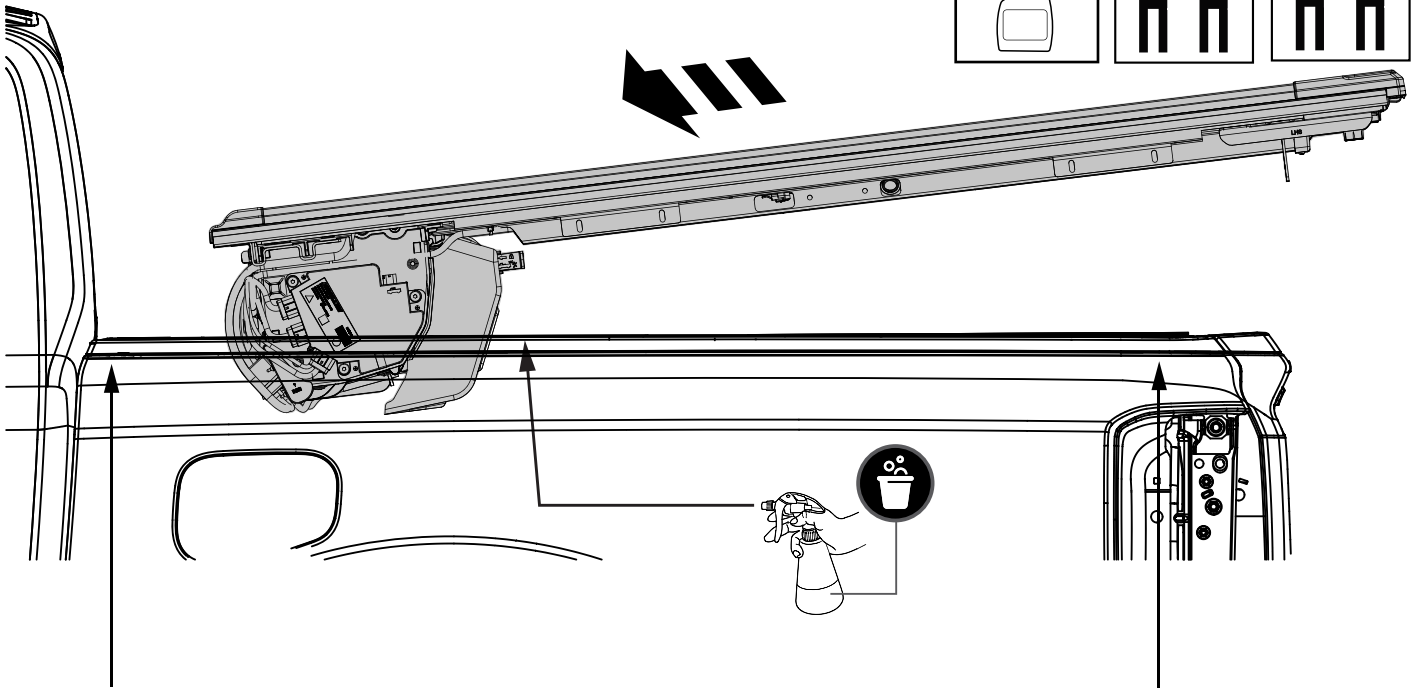

FRONT H-BAR CORNER BRACKET ENGAGEMENT WITH FRONT MOUNTING BRACKET - DETAIL VIEW (ROLLTRAC NOT SHOWN FOR CLARITY)

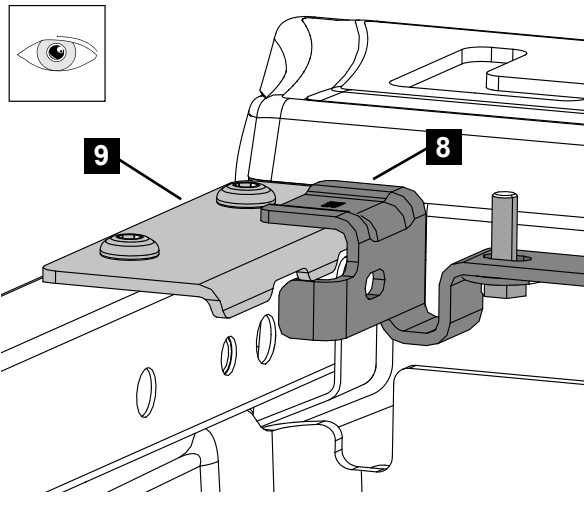

REAR MOUNTING BRACKET ENGAGEMENT WITH REAR SUPPORT BRACKET - DETAIL VIEW (ROLLTRAC NOT SHOWN FOR CLARITY)

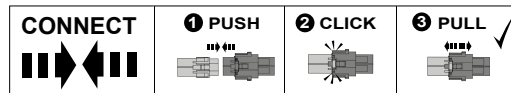
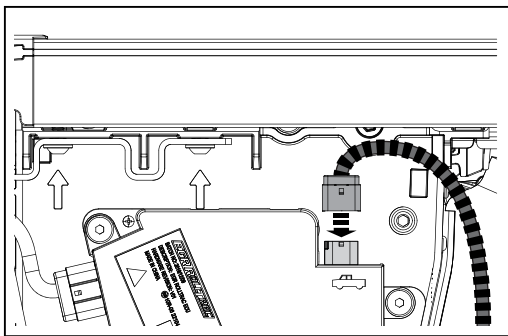
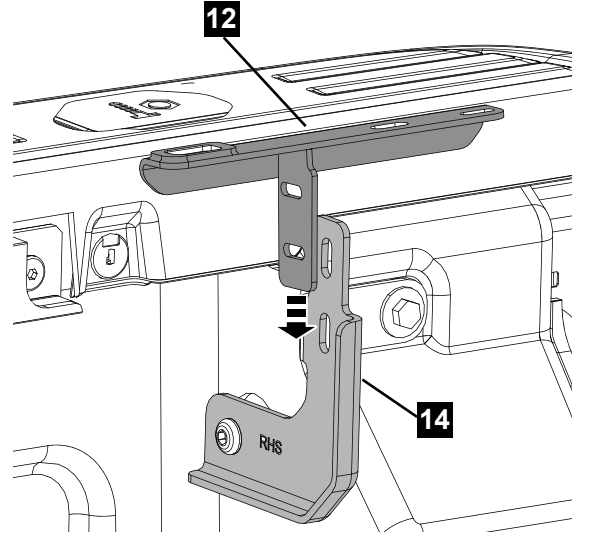

PULL THE CONNECTORS NOT THE CABLE

- 1** Spray the side rails seals with a soapy water solution to enable the Rolltrac to slide easily. Using two people on either side and one (or two) in the centre (to support and guide canister weight) place the cover carefully onto the header bar at front, as shown in detail.
Note: Present RollTrac from a low height (max 50mm above side rails) to avoid damage to product.
 Connect the Vehicle Harness to the ECU as shown.
Note: The front mounting brackets (7&8) must engage with the header bar corner bracket (9) as shown in detail.

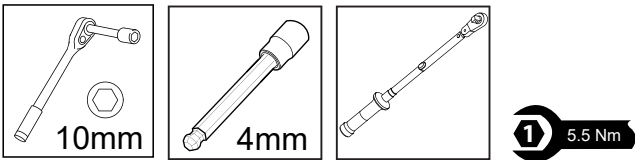

REAR MOUNTING BRACKET ENGAGEMENT WITH REAR SUPPORT BRACKET - DETAIL VIEW (ROLLTRAC NOT SHOWN FOR CLARITY)

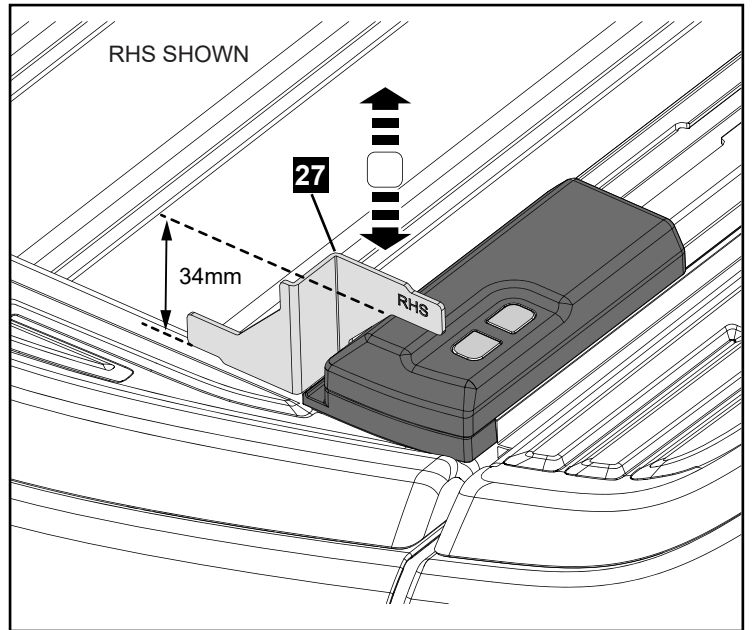
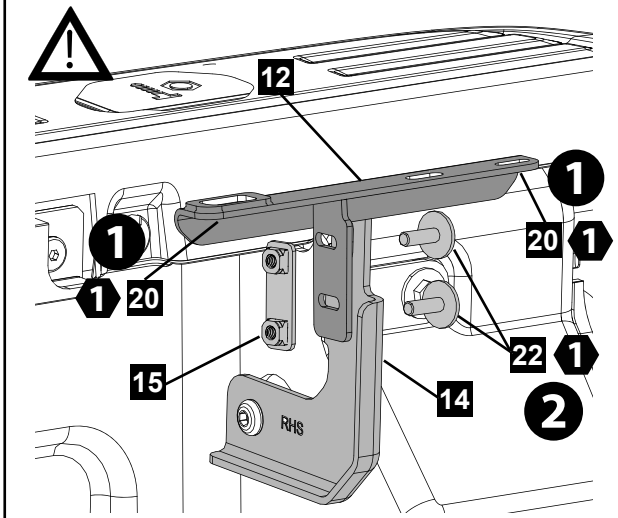

- 2** Join the two rear brackets (14&12) using the nut plate (15) and two screws (22). Do not torque at this stage. Carefully close the tailgate, lifting the side rails to avoid damage to rubber seals. Place the setup jig on top of the tailgate as shown and move the Rolltrac up or down till the endcap touches the jig, target offset is 34mm Torque the screws in a sequence shown above. Repeat for LHS.

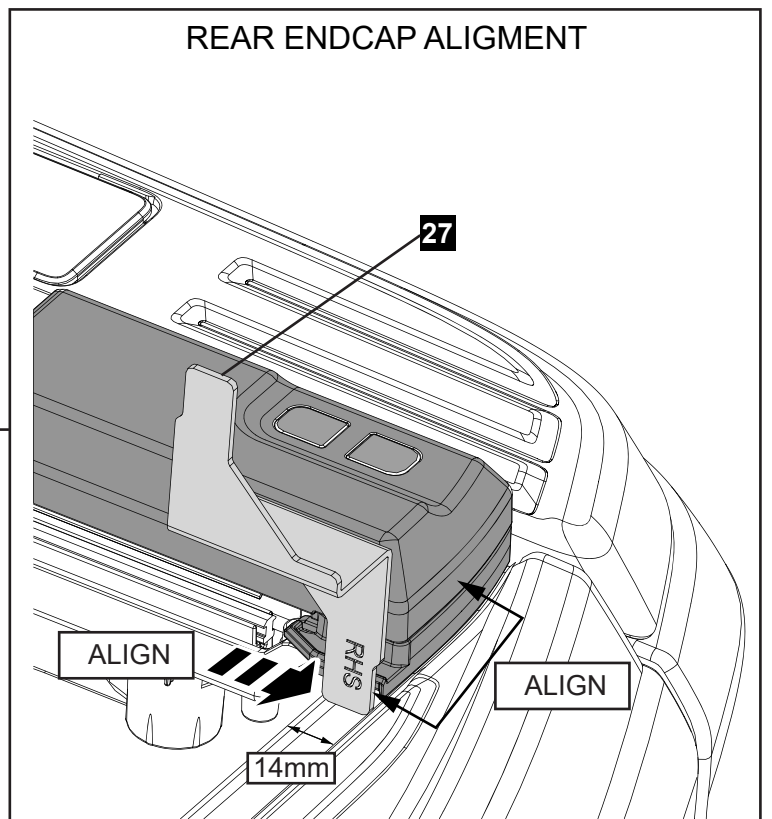
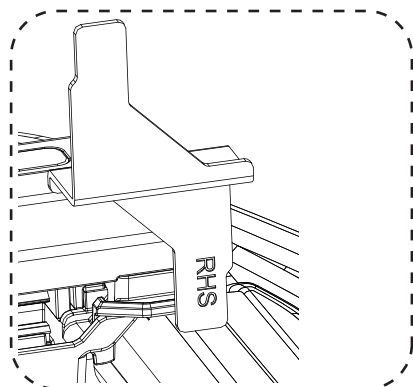
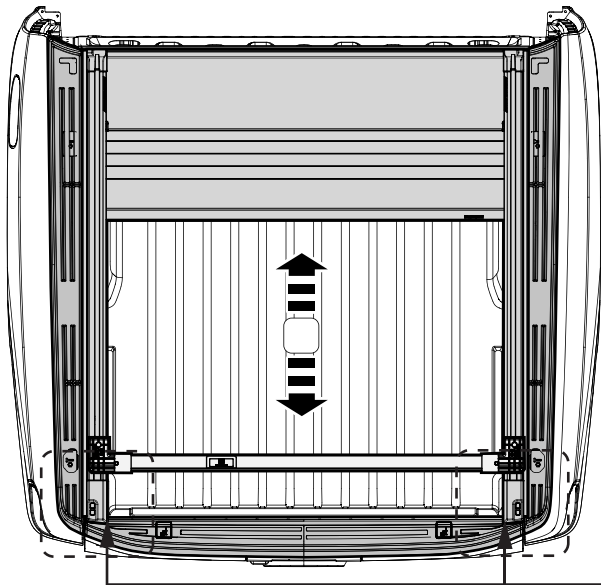

- 3** Using the setup jig (27) adjust the Rolltrac rearwards position. Place the jig on top of the tailgate as shown and move the Rolltrac to align the rear of the endcap with the setup jig as shown, target offset is 14mm. Repeat for LHS. NOTE: Apply short length of masking tape to bedcap to prevent scratching.

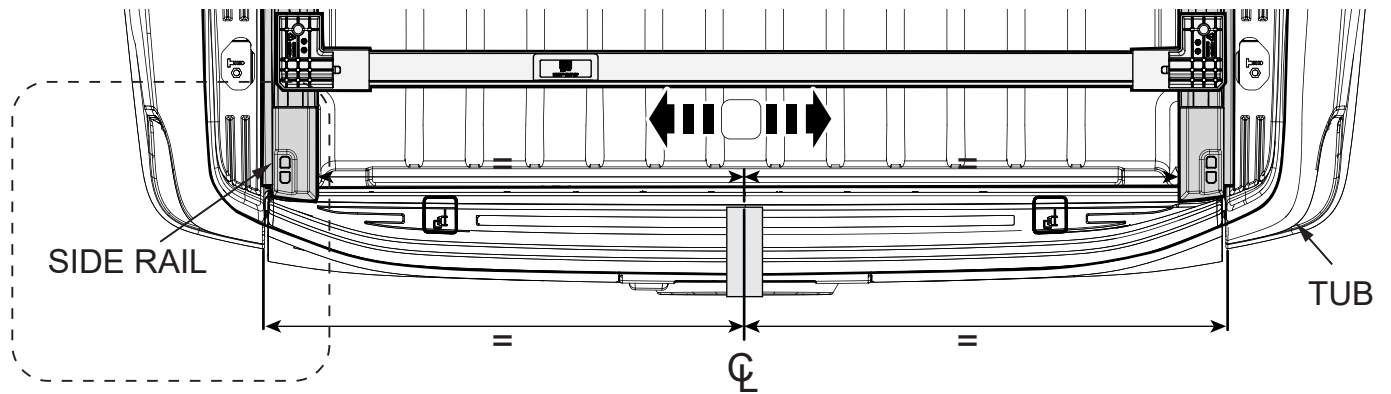
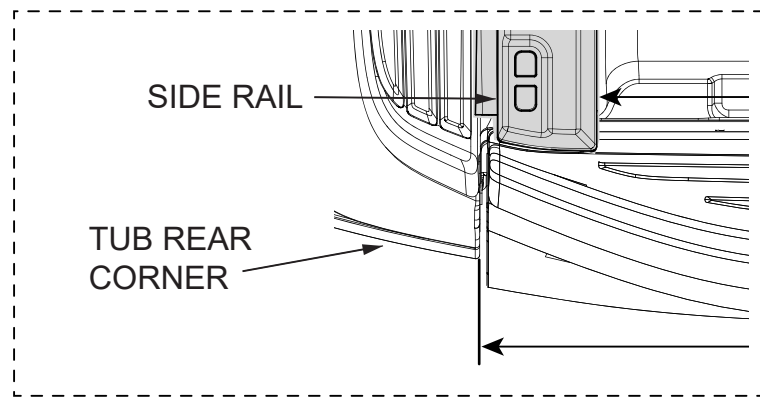

- 4** Apply masking tape at the centre of the tailgate. Measure the distance between the rear corners of the tub and draw a centre line on the masking tape. Measure the distance from the marked centre line to both rear corners of the EGR Rolltrac and ensure it is equally distanced. Adjust position if required as described in previous steps.

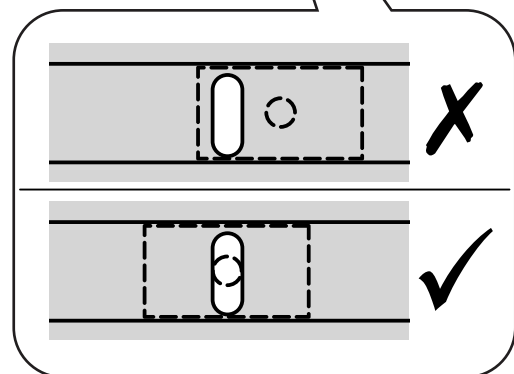
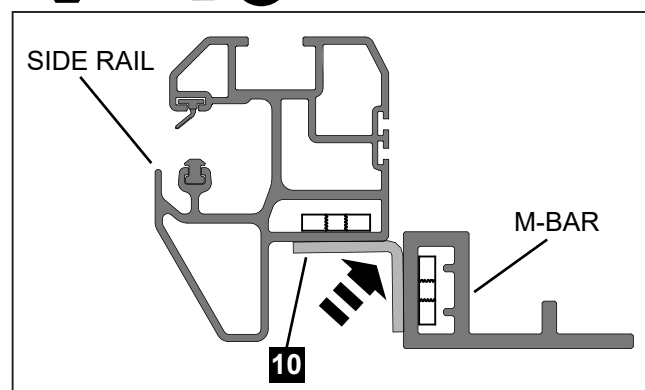
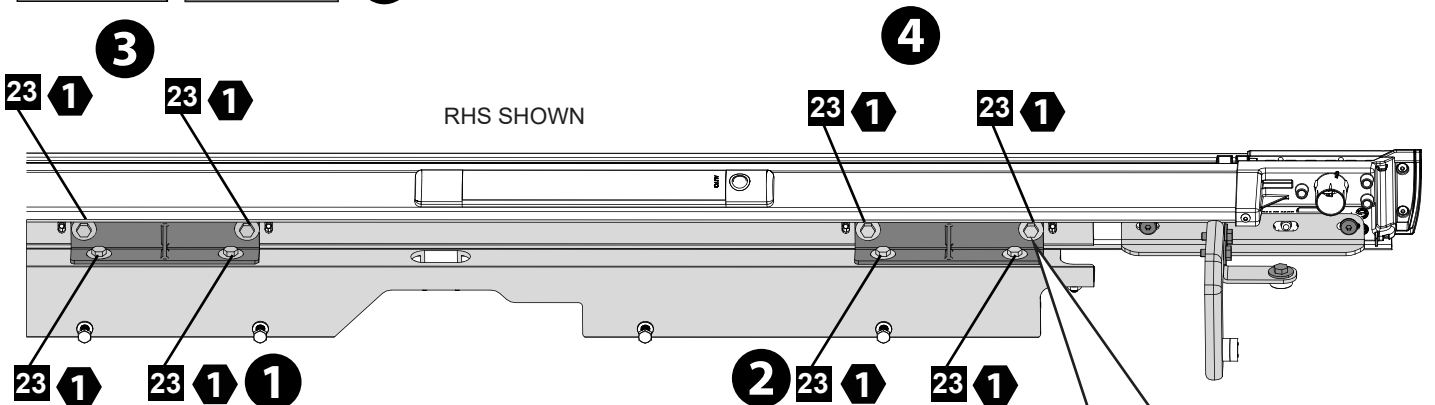
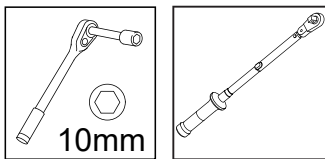

- 5** Push brackets (10) into position against mounting bar and side rail as shown in detail. Align taped plates (inside the M-BAR) with holes in brackets using a scribe or small screwdriver. Install and torque all screws to the specified settings in the order shown. Repeat for LHS.



A = A B = B

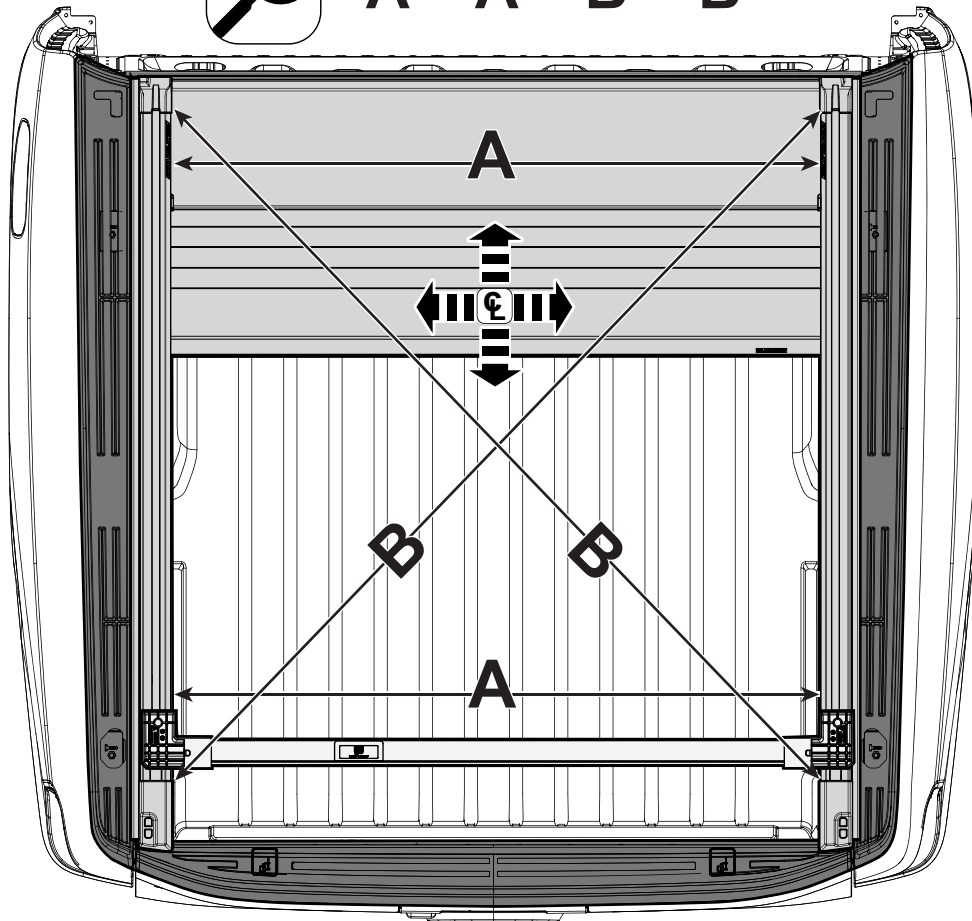

PERFORM FITMENT CHECK

- 6** Perform width and diagonal fitment check (bolts may need loosening for adjustment). Open and close the cover by hand, checking for smooth operation and consistent 1.5-2.0mm side to side free-play of slat assembly within side rails. If there are any tight spots, then re-adjust side rail width as described in previous steps. Remove the setup brace.

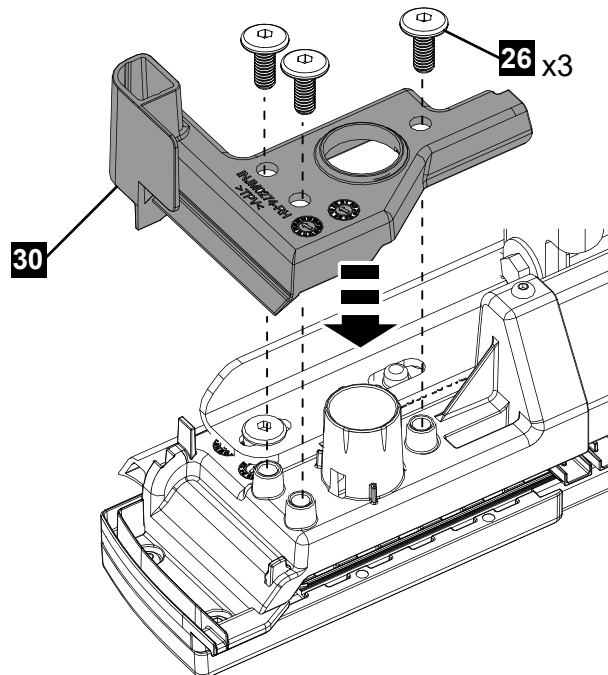
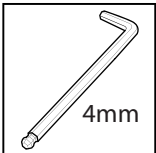

- 7** Fit the RHS water duct over the bottom of the RHS endcap and secure with 3 screws (26) as shown. **Important:** Hand torque screws (26) until fully seated (contact water duct surface). Repeat for LHS.

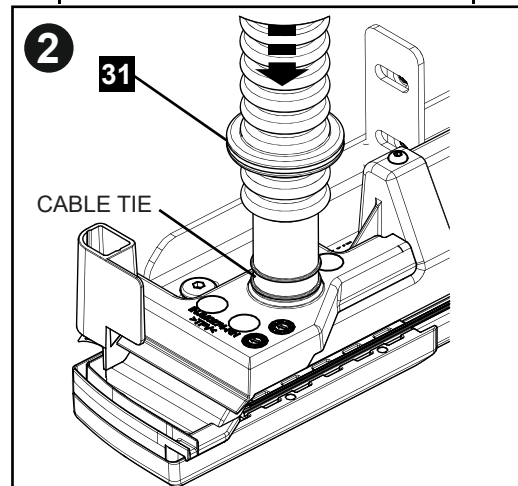
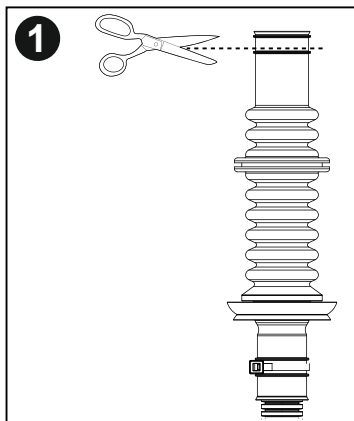
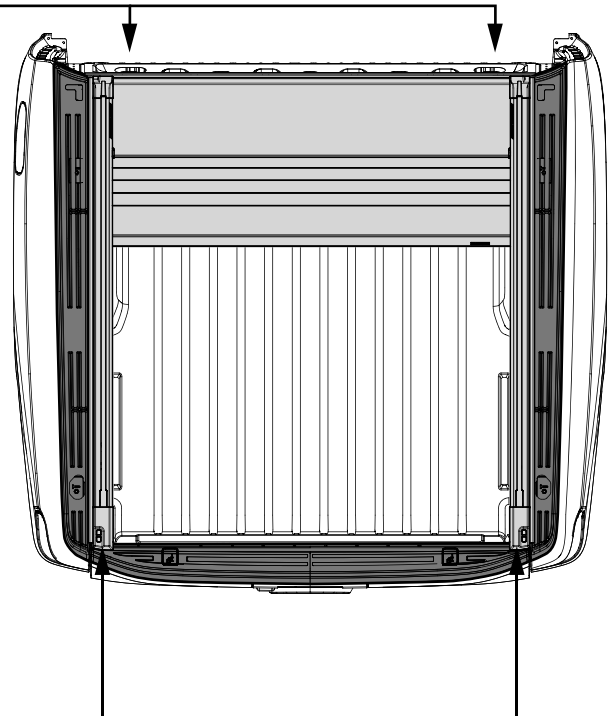
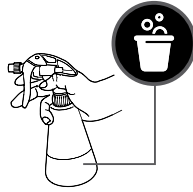
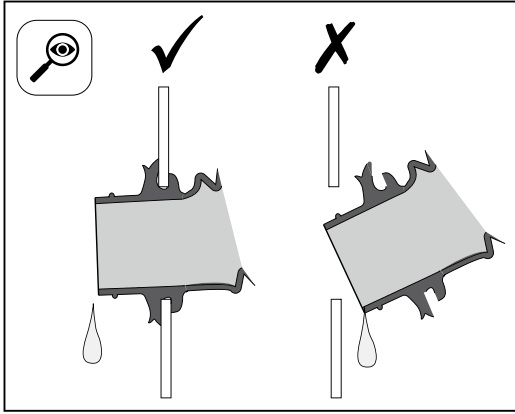

8 Check fitment and if required, trim the tube just above the bottom rib. Connect the RHS rear drain tube to the endcap and secure with a zip tie as shown. Repeat for LHS. Connect the front drain tubes to the canister. Use soapy water solution to help rubber slide over the fitting.

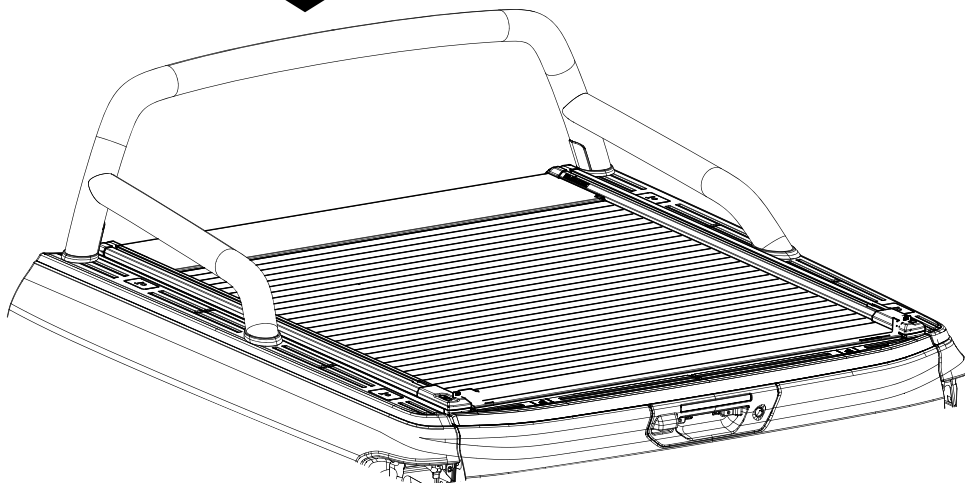

9 Follow manufacturer's instructions to refit accessories removed during tub preparation.

SILICONE LUBRICATION TO THE SPIRALS

(MODELS MAY VARY, IMAGES FOR REFERENCE ONLY)

1 Open tailgate and EGR Rolltrac

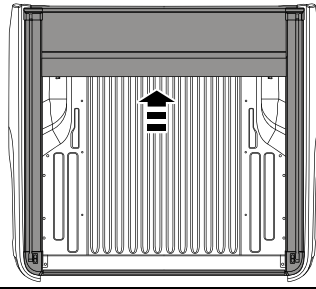
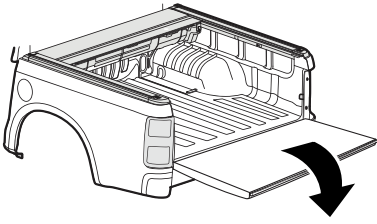

TOOLS REQUIRED:

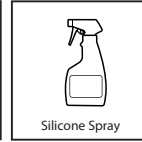
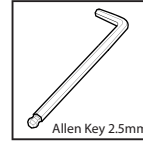

2 Using a 2.5mm Allen Key remove the 4 screws and open the inspection covers.
WARNING: Keep clear of moving parts and avoid unnecessary operation of the EGR Rolltrac while inspection covers are open.

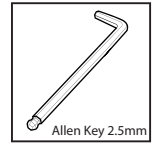
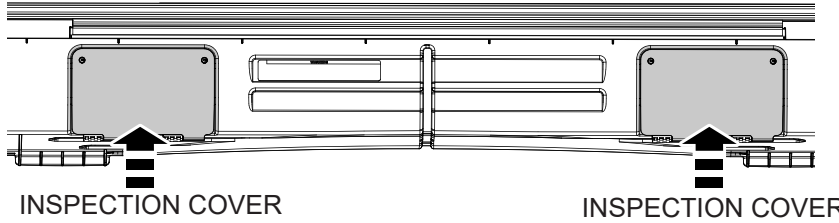

3 Close the EGR Rolltrac to access canister internals

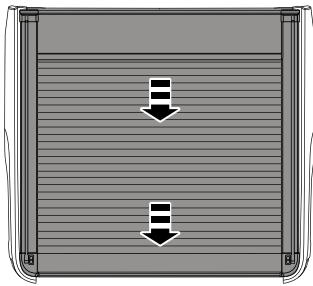

4 To avoid water leaks, look into the inspection points and check that the flanges of both front drain tubes are correctly engaged to the canister cover (without any kinking etc.), readjust if required.

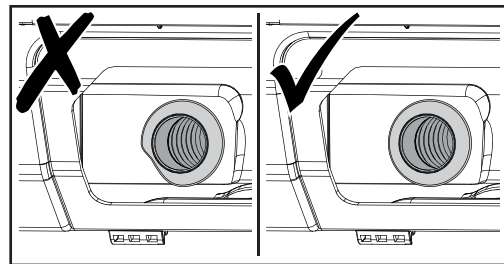

5 Using plastic compatible 100% Silicone Spray (ONLY) spray onto the spirals on both ends of the canister through the inspection points.

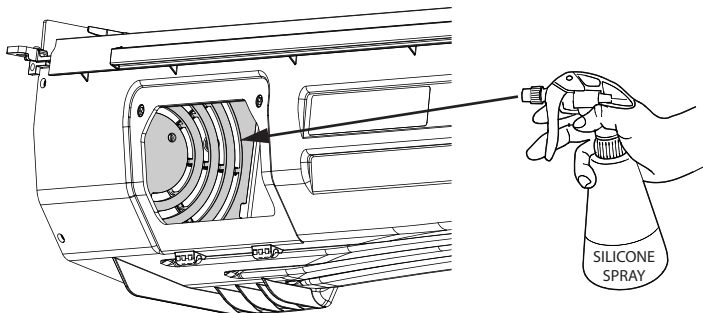

6 Open the EGR Rolltrac

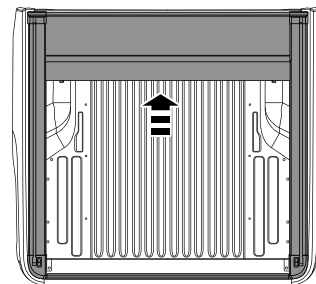

7 Close the inspection covers and secure with retained screws. Open and close the EGR Rolltrac to distribute lubricant and check operation.

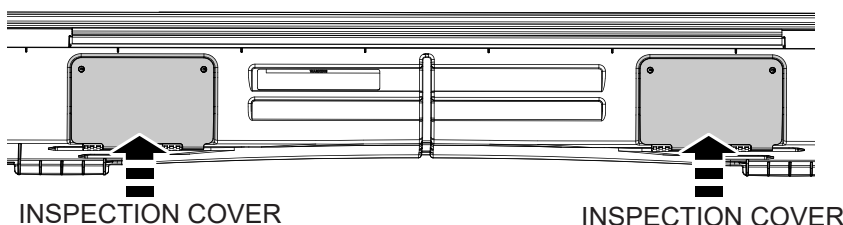

1. Insert fuse to EGR RollTrac harness.
2. Make sure the tailgate is open.
3. Engage motor, pull out lever (clutch).
4. Make sure the vehicle is unlocked and driver door open.
5. Press both buttons and hold for 5 sec. until light illuminates.



WARNING: Keep obstructions clear of cover during calibration mode.

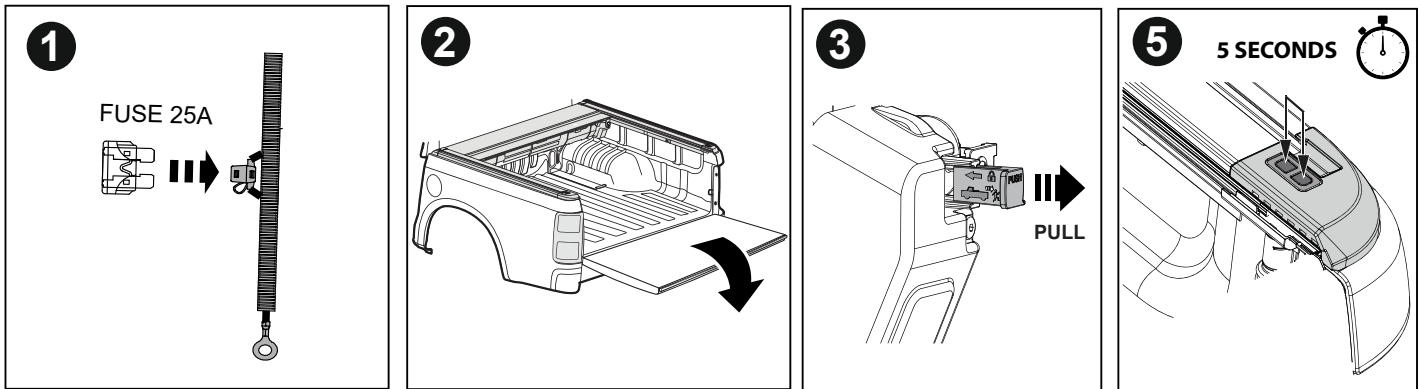

- Cover will CLOSE and OPEN once automatically.
- The EGR RollTrac internal LED light will pulse slowly during calibration and stop pulsing when calibration is complete.

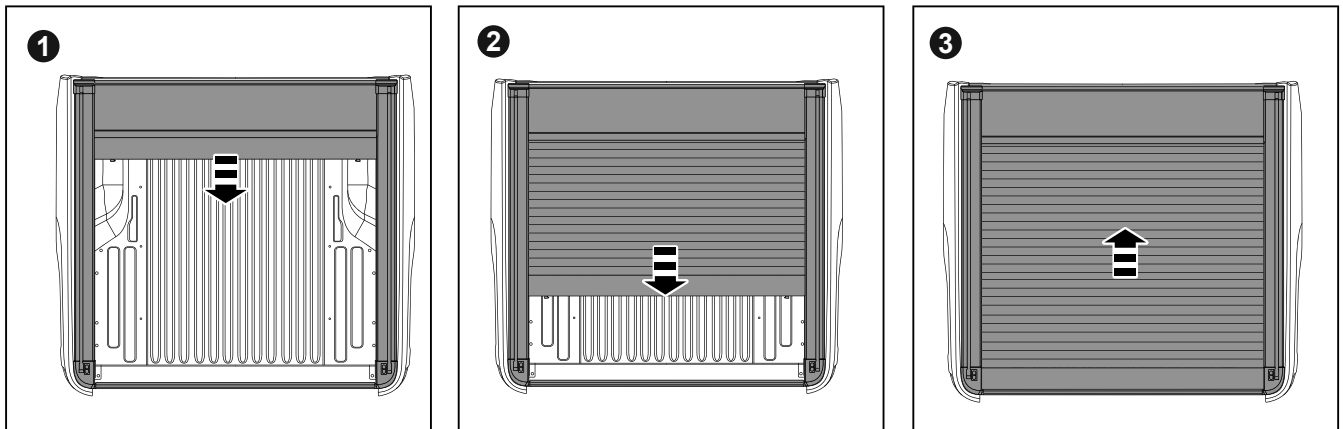
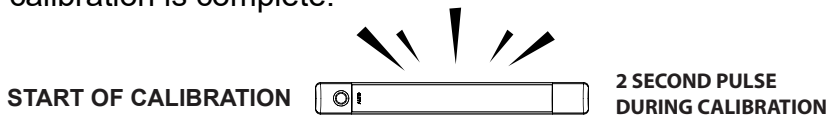

OPENING AND CLOSING PROCEDURE

(MODELS MAY VARY, IMAGES FOR REFERENCE ONLY)

Electric Opening Procedure:

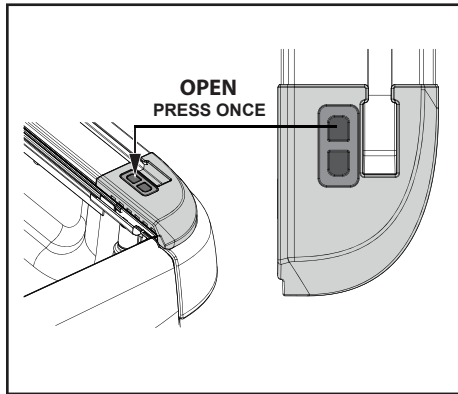
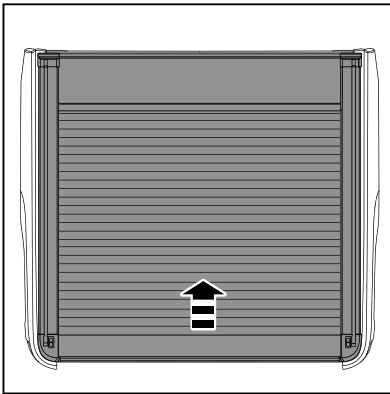

1. Press the front button on the EGR RollTrac side rail as shown.

Electric Closing Procedure:

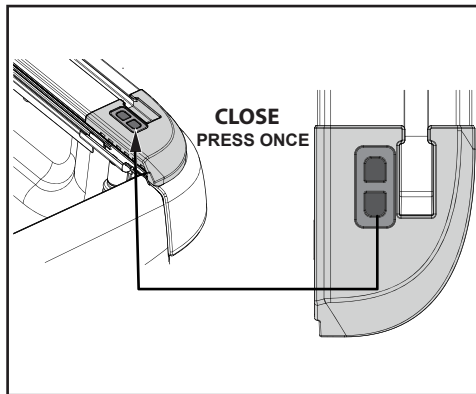
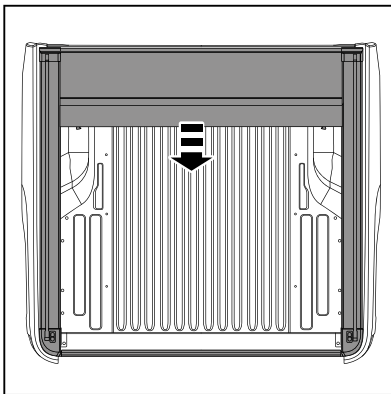

1. Press the rear button on the EGR RollTrac side rail as shown.

NOTE: EGR RollTrac should open and close smoothly. If cover does not lock or open correctly, please refer to the trouble shooting section in the Owners Manual. If the EGR RollTrac closing is slow, clean the siderails and ensure that no dirt or debris is inside the drive rail.

Manual Opening and Closing Procedure:

Locate the Clutch Disengagement Lever on the RH side of the cover and push the Clutch inward to disengage the motor. Pull the cover rearward or forward as required. Before driving vehicle ensure you re-engage the clutch.

IMPORTANT: If clutch was disengaged, calibration procedure needs to be re-run prior to electric operation.

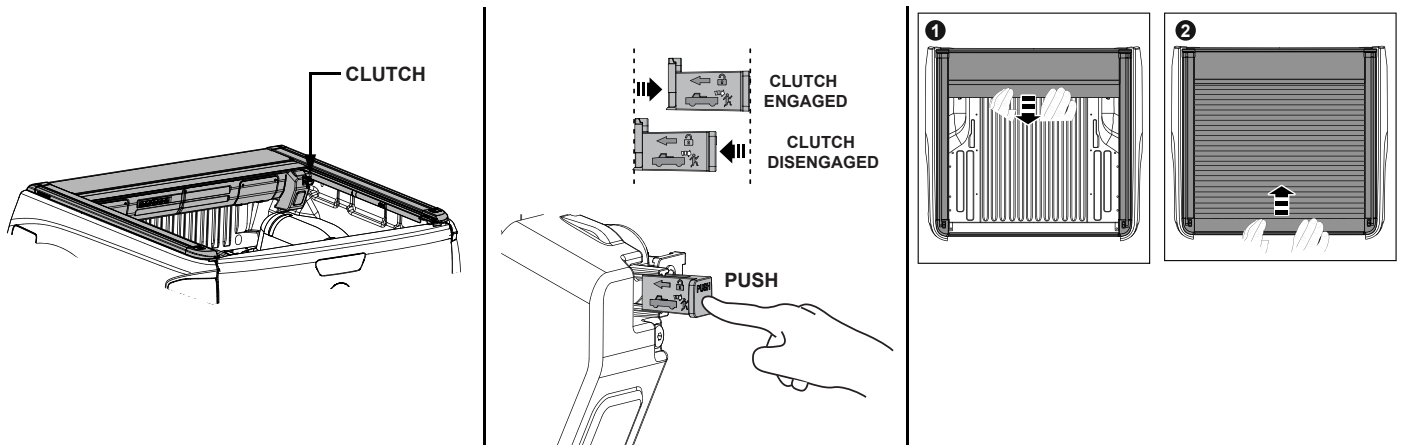

KEY FOB OPERATION



WARNING



- THIS DOCUMENT IS A SUPPLEMENT TO YOUR EGR ROLLTRAC OWNERS MANUAL, ENSURE THAT YOU READ BOTH DOCUMENTS AND FOLLOW ALL INSTRUCTIONS WHEN OPERATING THE EGR ROLLTRAC.
- DO NOT OPERATE THE EGR ROLLTRAC WHILE THE VEHICLE IS IN MOTION.
- EXERCISE CAUTION WHEN OPERATING THE EGR ROLLTRAC AT ALL TIMES – ALWAYS CHECK THE VEHICLE TUB / BED FOR POTENTIAL SAFETY RISKS (OBSTRUCTIONS, ENTRAPMENT etc) PRIOR TO OPERATION.

LOCKING / AUTO CLOSE PROCEDURE

Key Fob

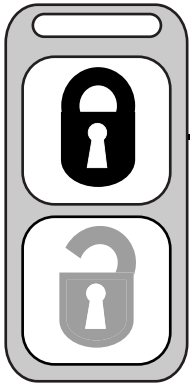

1. Press lock twice within 2 second, the vehicle will lock, if closed the RollTrac will lock, if open it will auto close.
2. To pause while in auto close motion, press lock once and the RollTrac will stop.
3. To resume auto close, press lock twice within 2 second.
4. When auto close is complete the RollTrac will auto lock.

UNLOCKING / AUTO OPEN PROCEDURE

Key Fob

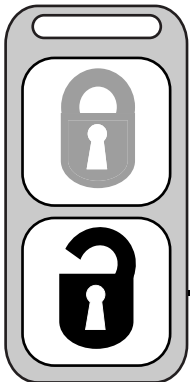

1. Press unlock twice within 2 second, the vehicle will unlock and the RollTrac will auto open.
2. To pause while in auto open motion, press unlock button once and the RollTrac will stop.
3. To resume auto open, press unlock twice within 2 second.
4. When auto open is complete the RollTrac will remain open until operated by either the key fob or the RollTrac buttons.

NOTES

- If pause is activated by the fob whilst auto closing, the RollTrac can be closed and paused using the RollTrac close button. Reactivate both Rolltrac buttons by unlocking the vehicle.
- If the RollTrac is open and the lock button is only pressed once, the vehicle and the RollTrac will lock.