

## Geschlossen / Closed

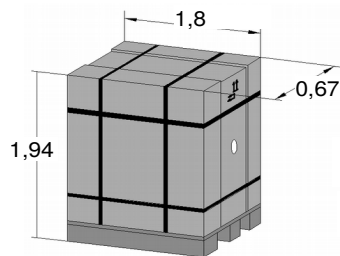

Net weight: 57,00 kg  
 Gross weight: 87,00 kg  
 Volume: 2,34 m<sup>3</sup>

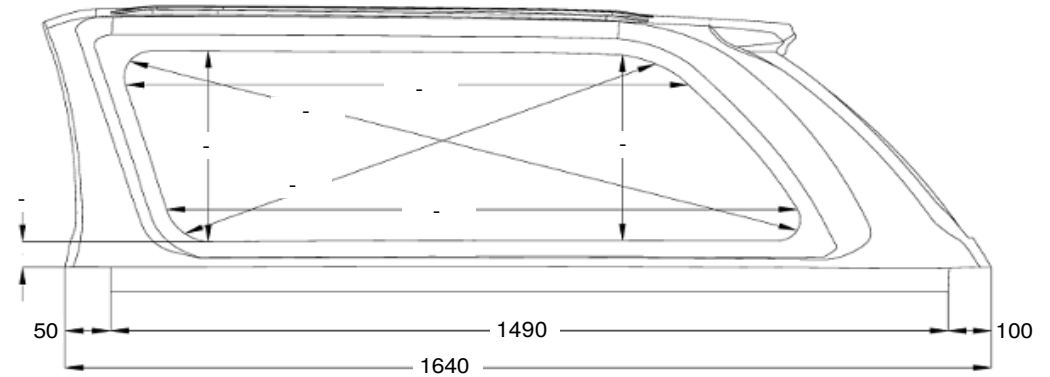
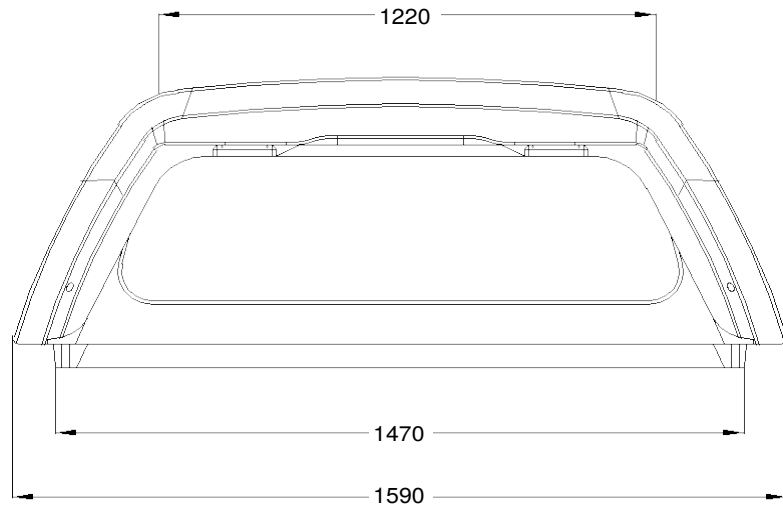
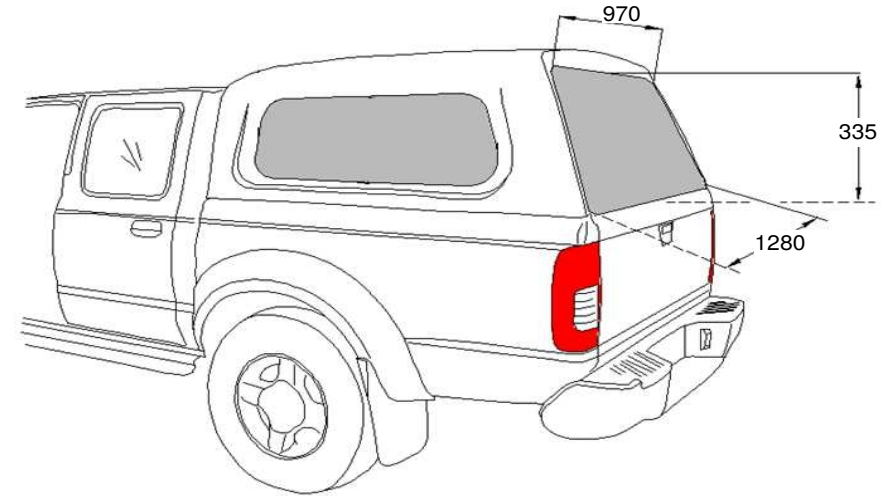
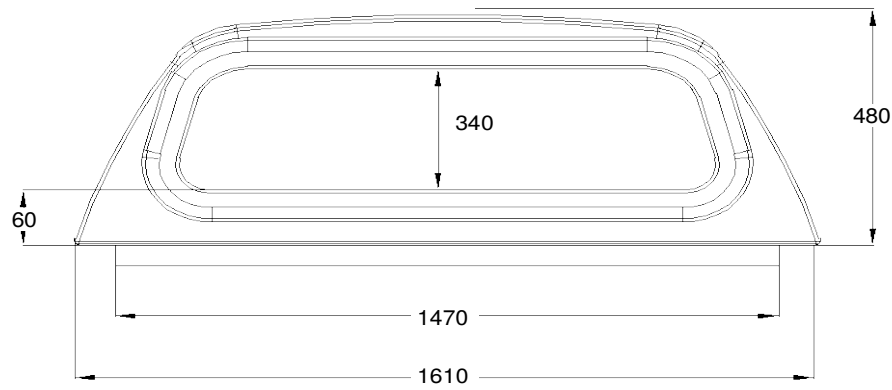
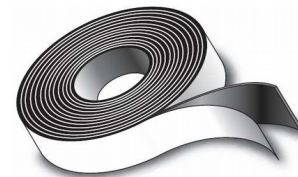

10 X 40 X 10000 GKS ECONOMY - 3 m  
 20 x 10 x 5000 GKS ECONOMY - 1,5 m

NI DC RH04 IES LAK - 1900864  
 Wymiary nadbudowy samochodowej - Dimensions of hardtop

# Geschlossene Seitenfenster / Closed side windows **ROAD RANGER®**

NI DC RH04 I E F LAK - 1900865

Wymiary nadbudowy samochodowej - Dimensions of hardtop

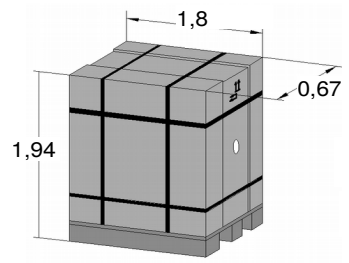
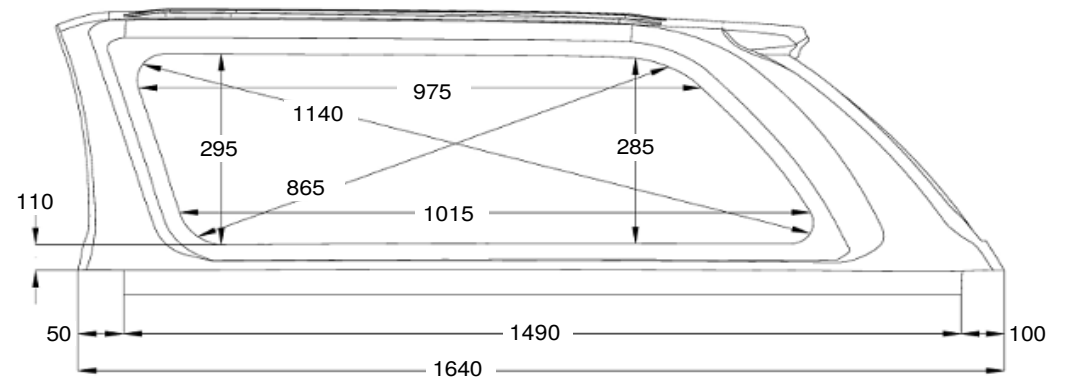
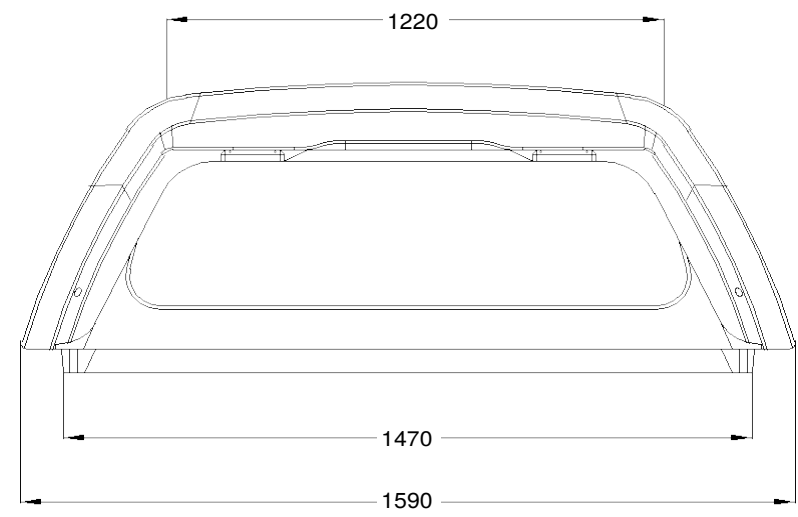
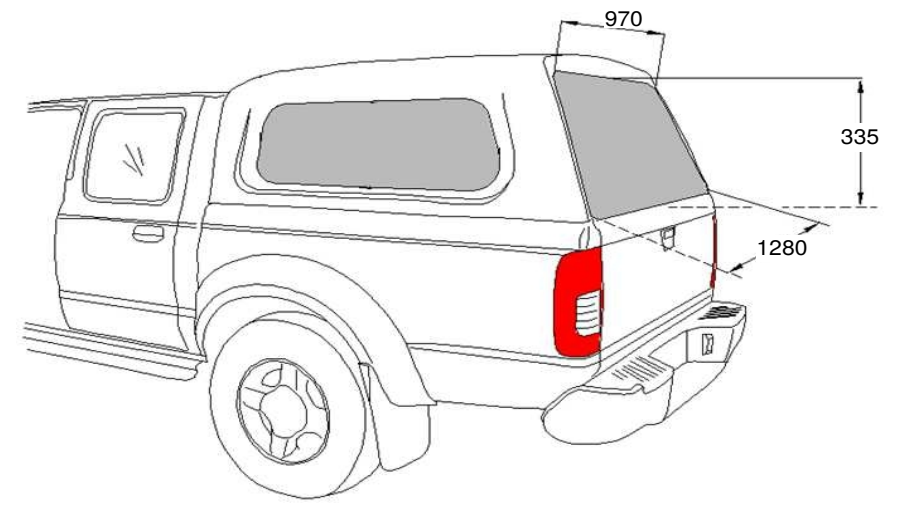
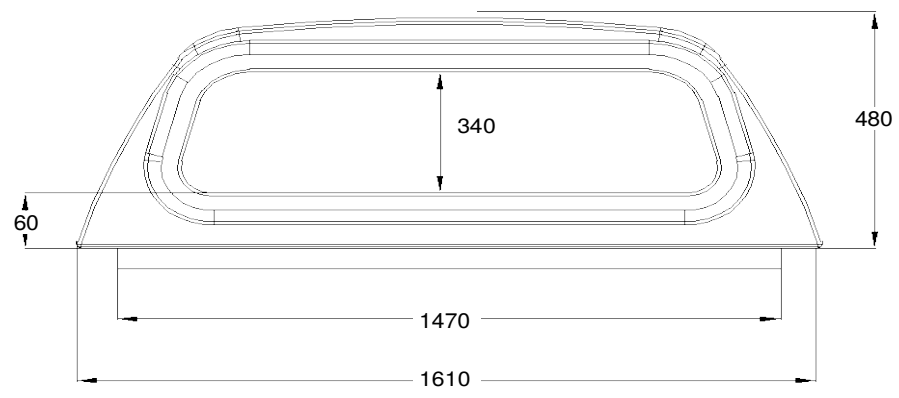

Net weight: 66,00 kg  
 Gross weight: 96,00 kg  
 Volume: 2,34 m3

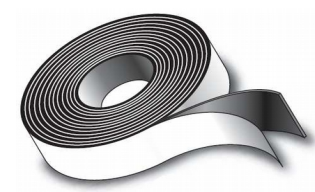

10 X 40 X 10000 GKS ECONOMY - 3 m  
 20 x 10 x 5000 GKS ECONOMY - 1,5 m

## Kunststoffseitenklappen / Plastic side flaps

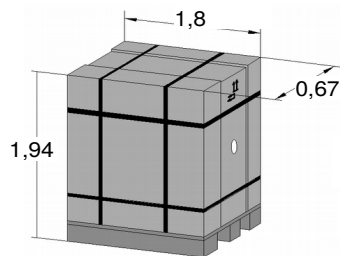
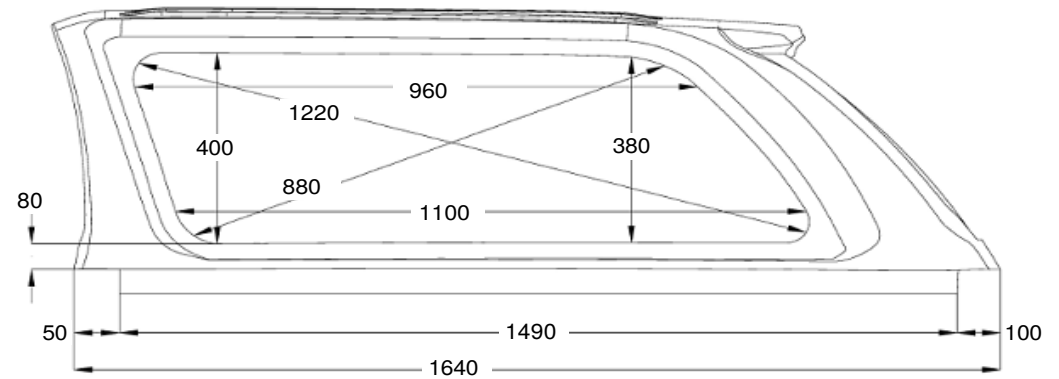
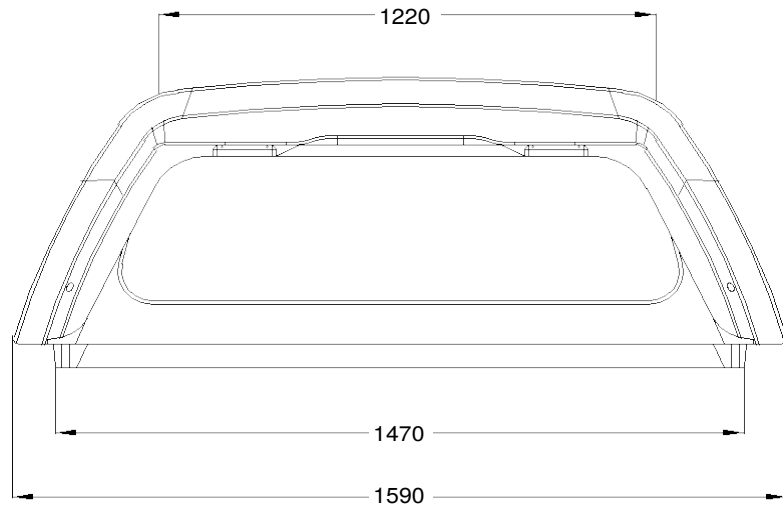
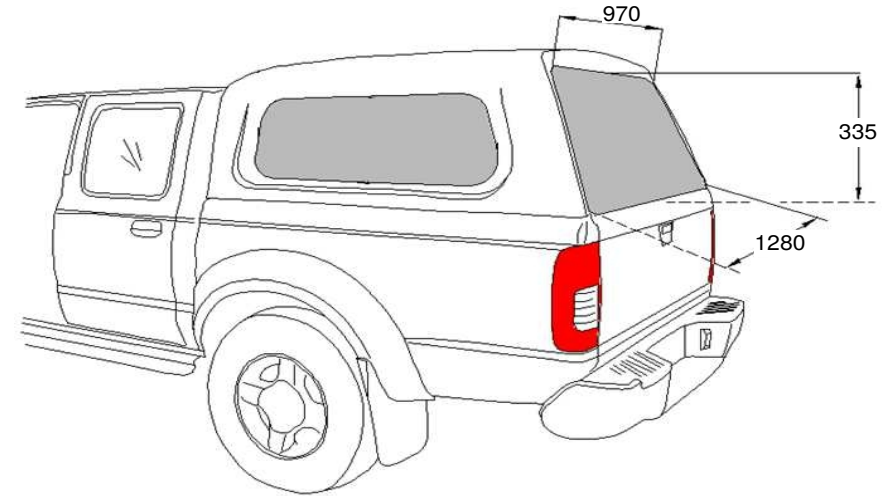
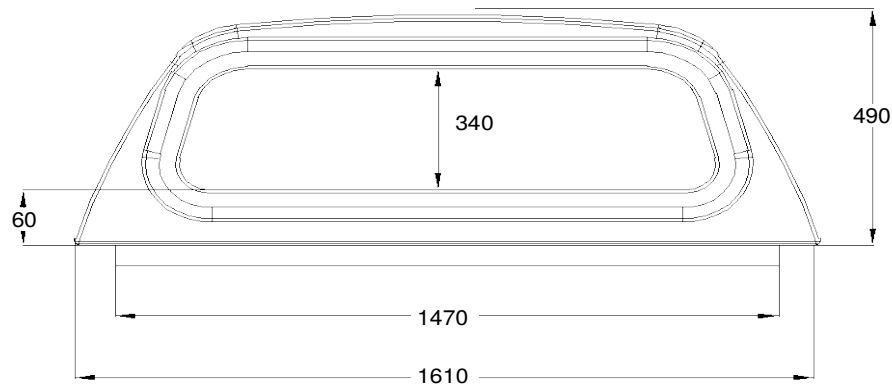

Net weight: 75,00 kg  
 Gross weight: 105,00 kg  
 Volume: 2,34 m<sup>3</sup>

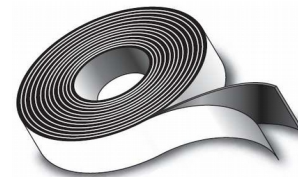

10 X 40 X 10000 GKS ECONOMY - 3 m  
 20 x 10 x 5000 GKS ECONOMY - 1,5 m

NI DC RH04 IE S2 LAK - 1900914  
 Wymiary nadbudowy samochodowej - Dimensions of hardtop

## Glasseitenklappen / Glas side flaps

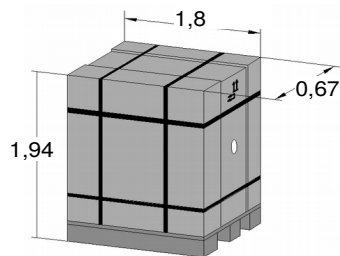
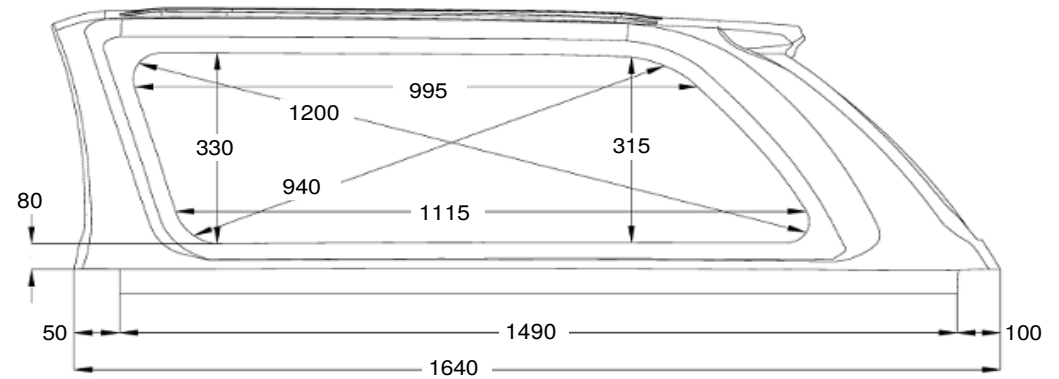
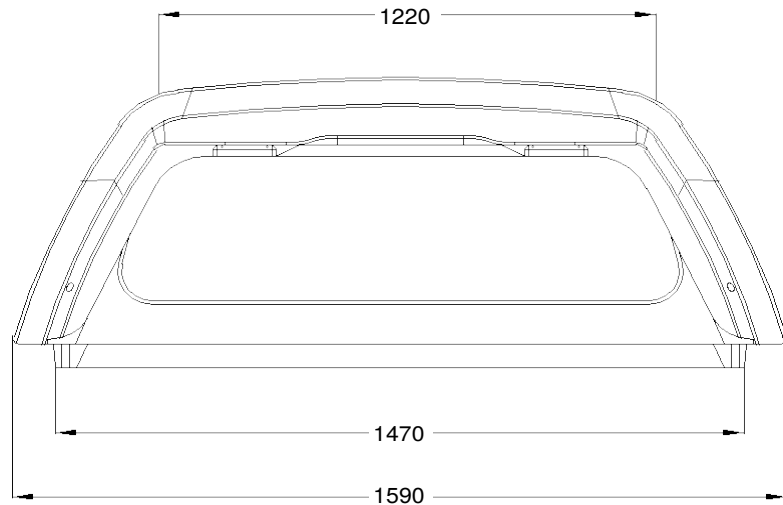
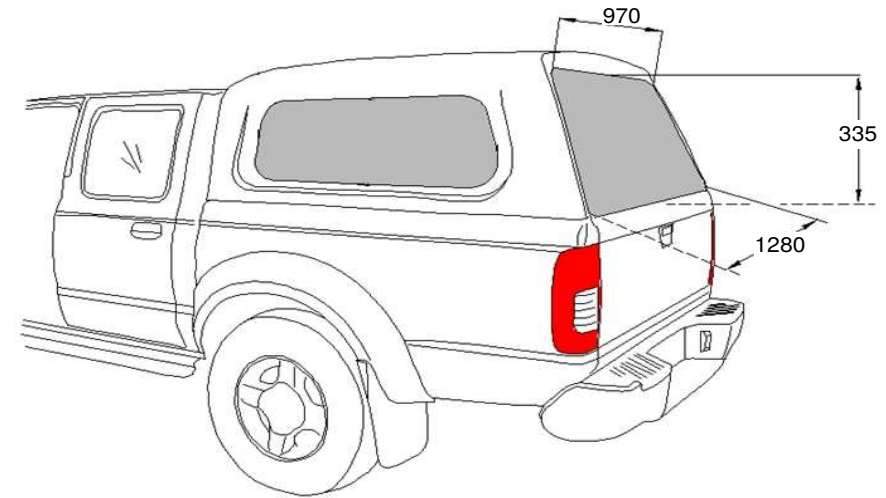
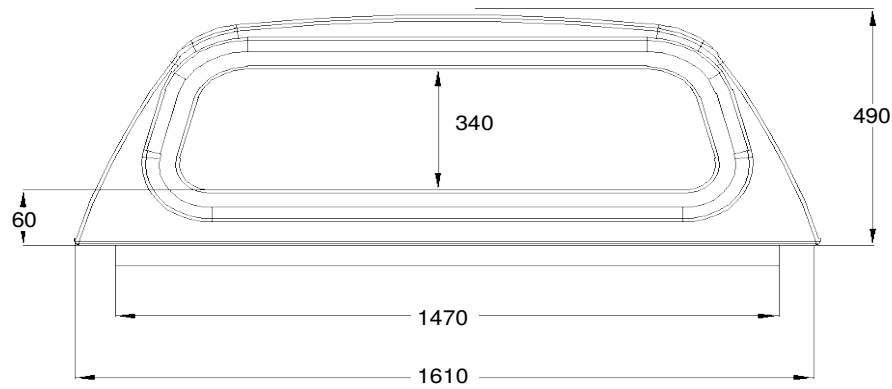

Net weight: 75,00 kg  
 Gross weight: 105,00 kg  
 Volume: 2,34 m<sup>3</sup>

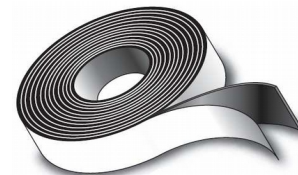

10 X 40 X 10000 GKS ECONOMY - 3 m  
 20 x 10 x 5000 GKS ECONOMY - 1,5 m

NI DC RH04 IE FS2 LAK - 1900866  
 Wymiary nadbudowy samochodowej - Dimensions of hardtop