

ET 400011

D Bitte lesen Sie diese Einbau-Anleitung gründlich durch, bevor Sie mit der Montage anfangen. Garantie wird nur gewährt, wenn die Montage von einer Fach-werkstatt ausgeführt worden ist.
Änderungen hinsichtlich Ausstattung, Konstruktion, Abbildungen und Text vorbehalten.

E Lea por tanto con atención este manual (folleto) antes de que la instalación comienza. Garantía es válida solamente si la instalación de este producto fue instalada por medio de una distribuidora autorizada.
Cambios en proyecto, construcción, retrato y texto son prohibidos.

F Lisez cette notice de montage soigneusement avant l'illustration. Une garantie est seulement délivrée si l'installation a été exécuté par un commerçant.
Sous réserve de modifications de projet, construction, illustrations et texte.

GB Please read this mounting manual carefully, before you start the installation. Warranty is guaranteed only when installation is done by your dealer's garage.
Modification related to design, construction, illustrations and text are reserved.

H Szerelés előtt alaposan tekintse át a szerelési útmutatót. Garanciát csak abban az esetben vállalunk, ha a felépítmény felhelyezése szakműhelyben történik. A változtatás jogát a külső, a szerkezet, a képek és a szöveg terén fenntartjuk!

I Si prega di prendere attentamente visione delle presenti istruzioni di montaggio prima di procedere all'installazione dell'hardtop. La garanzia è valida solamente se il montaggio è stato eseguito da un'officina autorizzata.
Con riserva di modifiche relative alla dotazione, costruzione, immagini e testo.

P Leia este manual de montagem cuidadosamente, antes de iniciar a instalação. A garantia só é considerada apenas quando a montagem for efectuada por uma oficina especializada.
Com reserva de modificações relacionadas com design, construção, ilustrações e texto.

PL Prosimy zapoznać się z instrukcją przed rozpoczęciem instalacji nadbudowy. Gwarancja zostanie uznana tylko wtedy gdy instalacja zostanie wykonana przez autoryzowanego dealera. Jakkolwiek zmiana wyglądu, konstrukcji, ilustracji lub tekstu jest zabroniona.

RU Внимательно прочитайте данную инструкцию, до того, как начнете установку. Гарантийные обязательства выполняются только при условии произведения установки на СТО Вашего официального дилера. Инструкция описывает установку различных моделей хардтопов. Рисунки хардтопов представленные в данной инструкции могут отличаться от внешнего вида Вашей модели.

S Läs noggrant igenom denna monteringsanvisning innan du börjar Installationsarbetet. Garanlin gäller endast då installationen är utförd av en auktoriserad verkstad eller är fackmannamässigt utförd.
Med reservation för modifieringar gällande design, konstruktion, illustrationer och text.

Montageanleitung >> Инструкция по установке >> Montageanleitung >> Instruções de montagem >> Montageanleitung >> Instruções de montagem >> Montageanleitung >> Instruções de montagem >> Montageanleitung >> Instruções de montagem >> Montageanleitung >> Instruções de montagem >> Montageanleitung >> Instruções de montagem

Installation instruction >> Instructions de montage >> Istruzioni di montaggio >> Instruções de montagem >> Montageanleitung >> Instruções de montagem >> Montageanleitung >> Instruções de montagem >> Montageanleitung >> Instruções de montagem >> Montageanleitung >> Instruções de montagem >> Montageanleitung >> Instruções de montagem

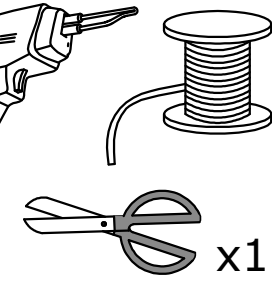
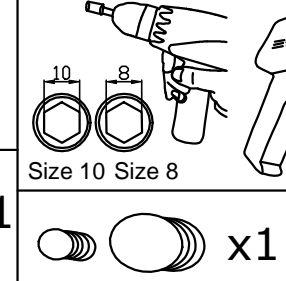
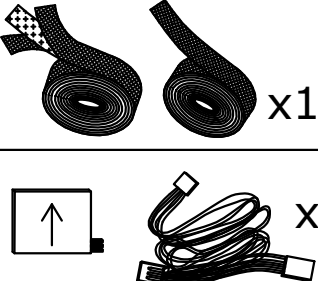
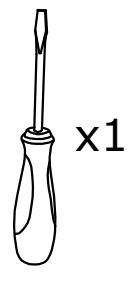
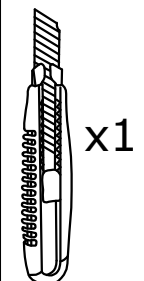
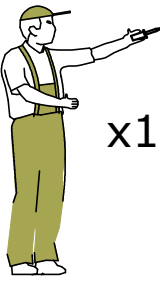

Dismantling Demontage

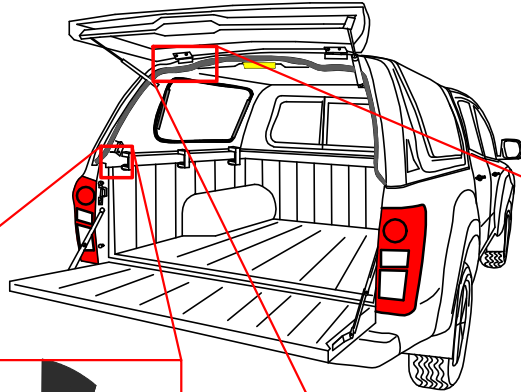

1.

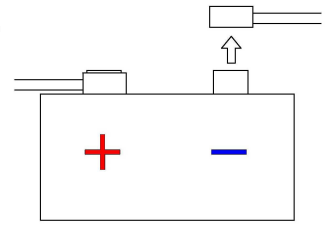

2.

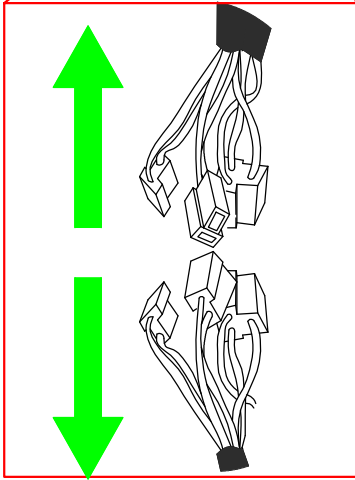

3.

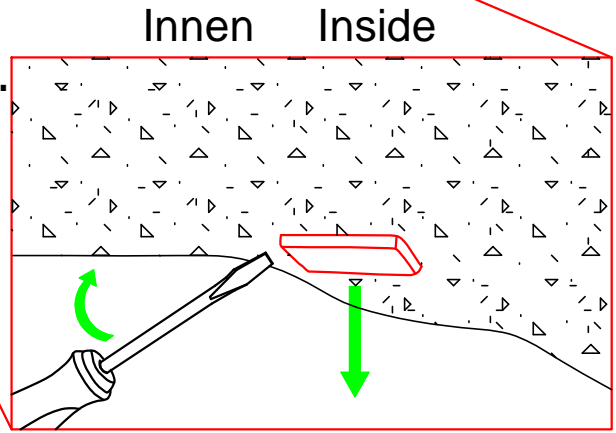

Außerhalb Outside

4.

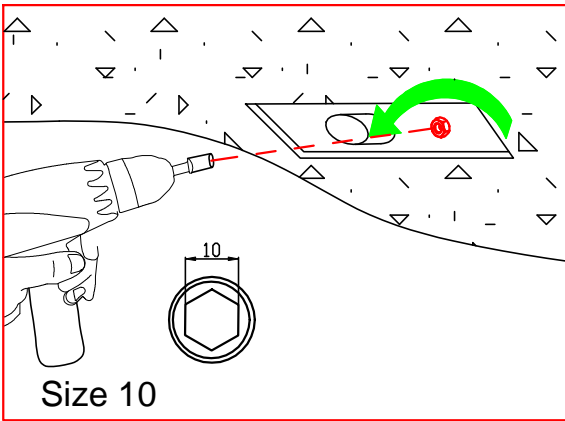

Size 10

5.

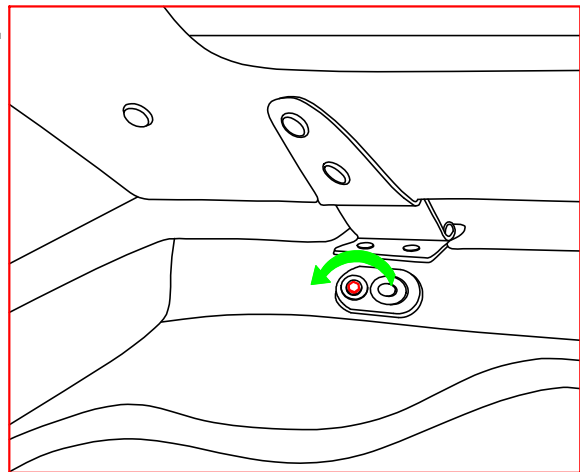

6.

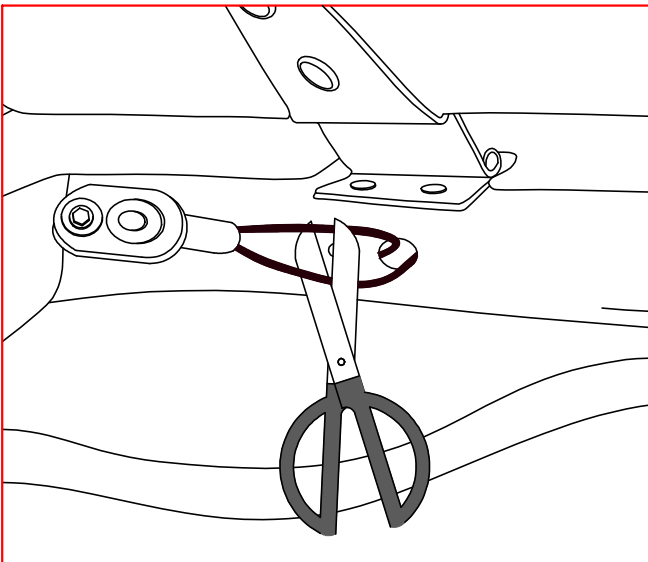

7.

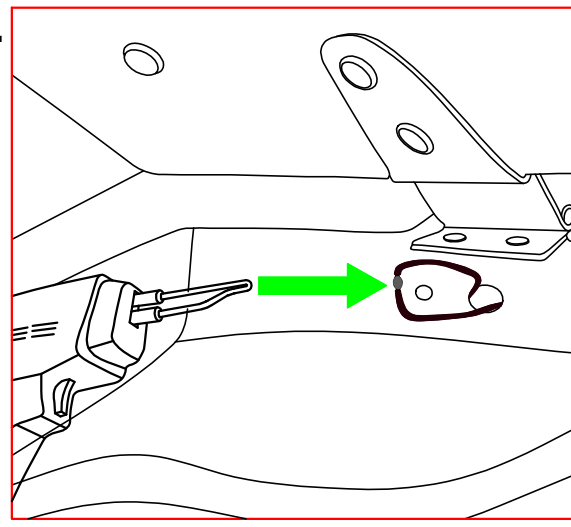

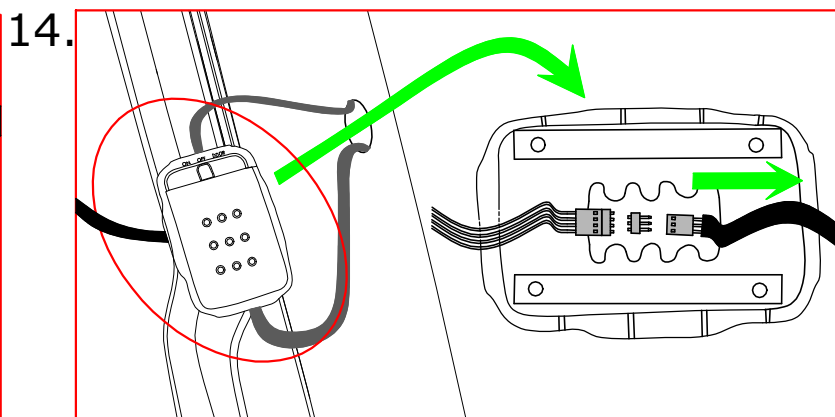
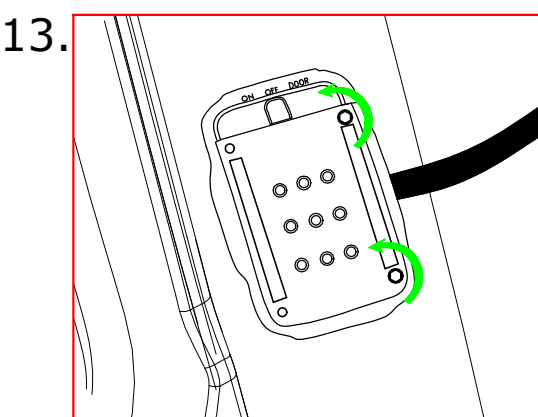
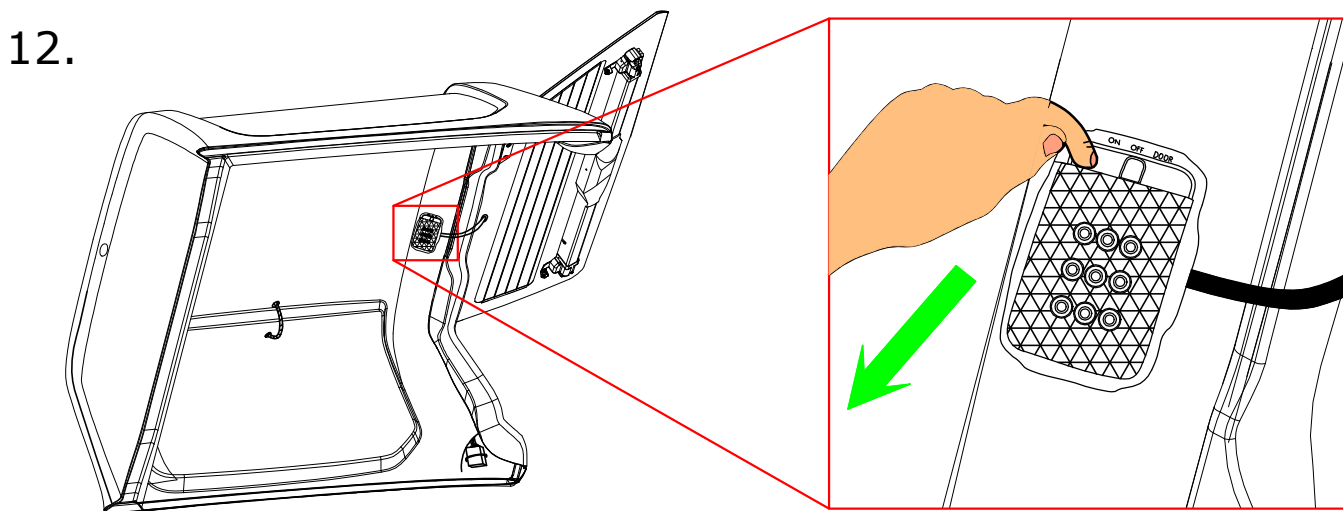
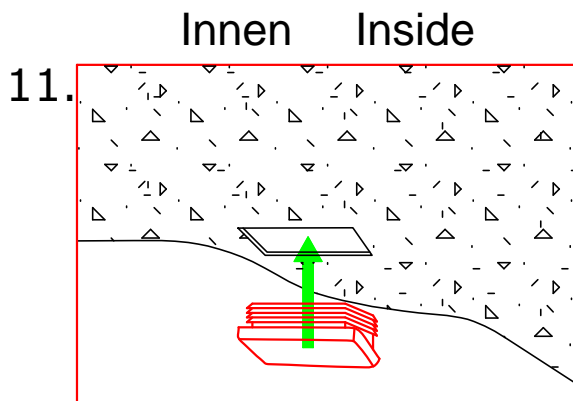
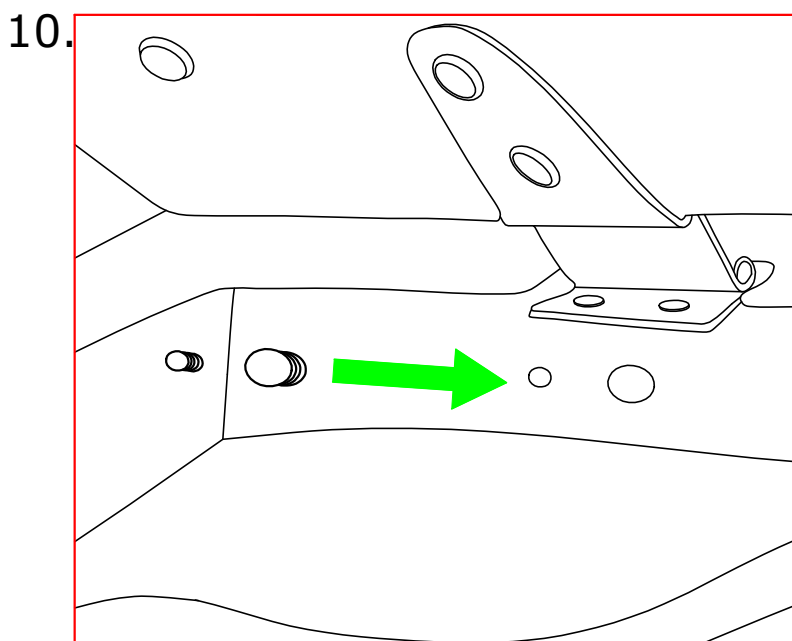
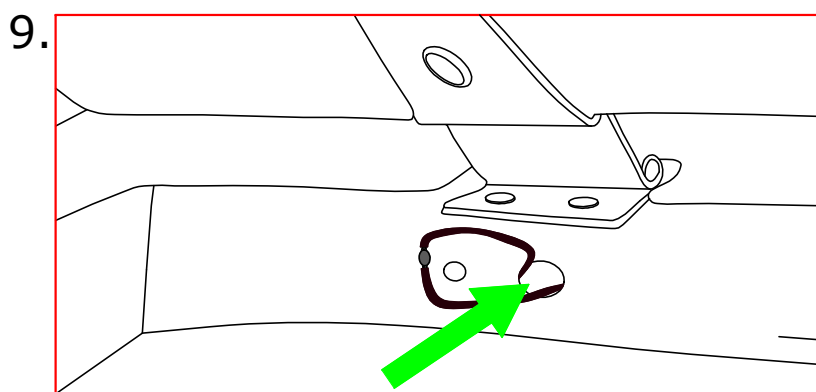
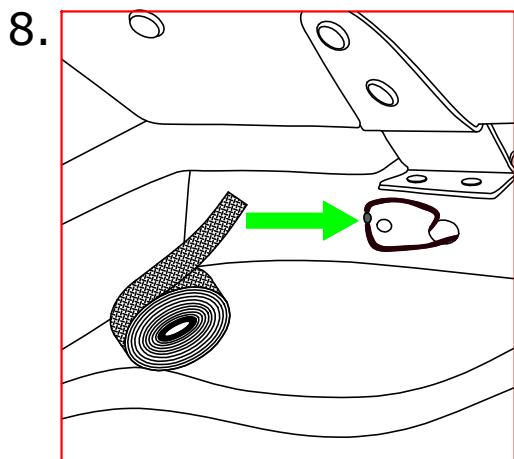

15.

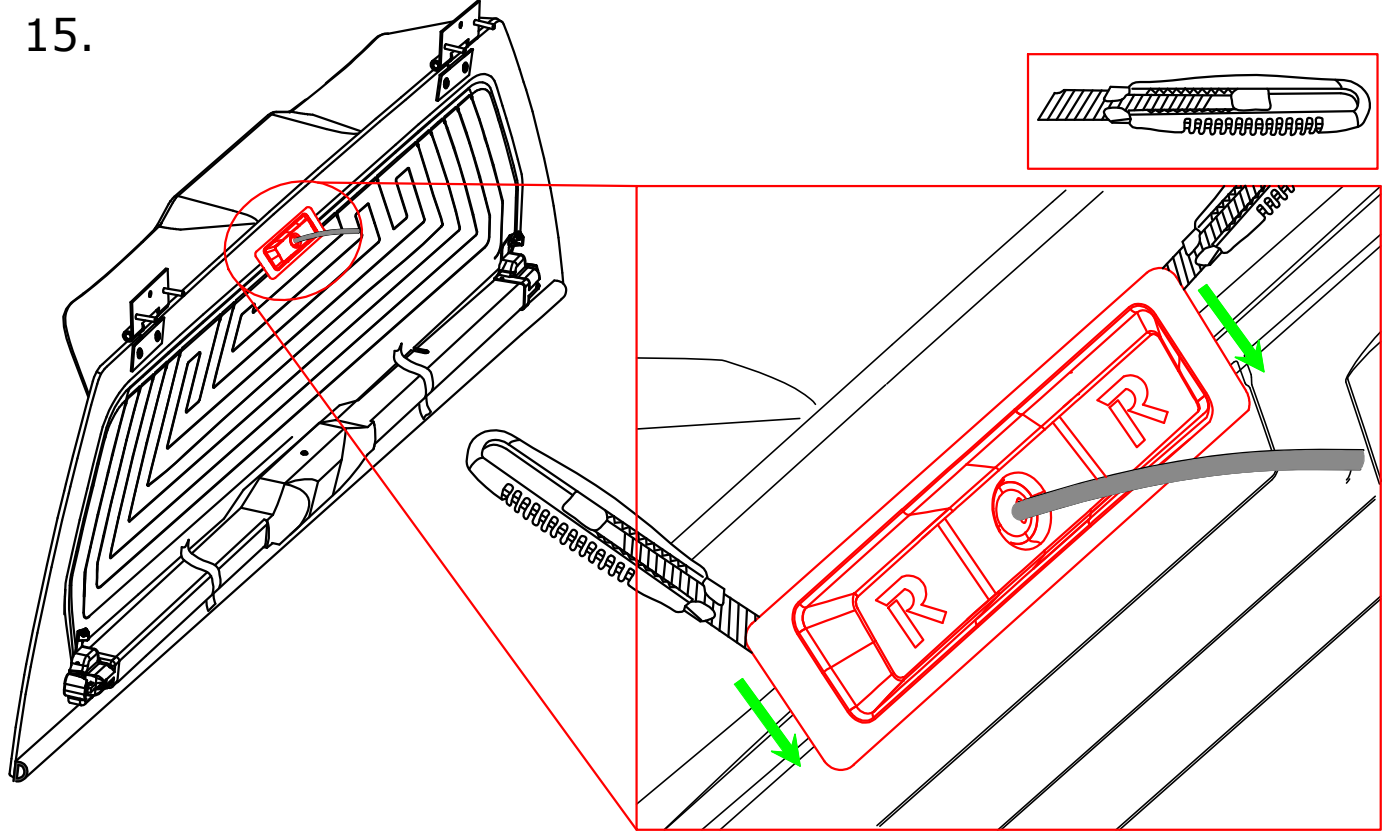

16.

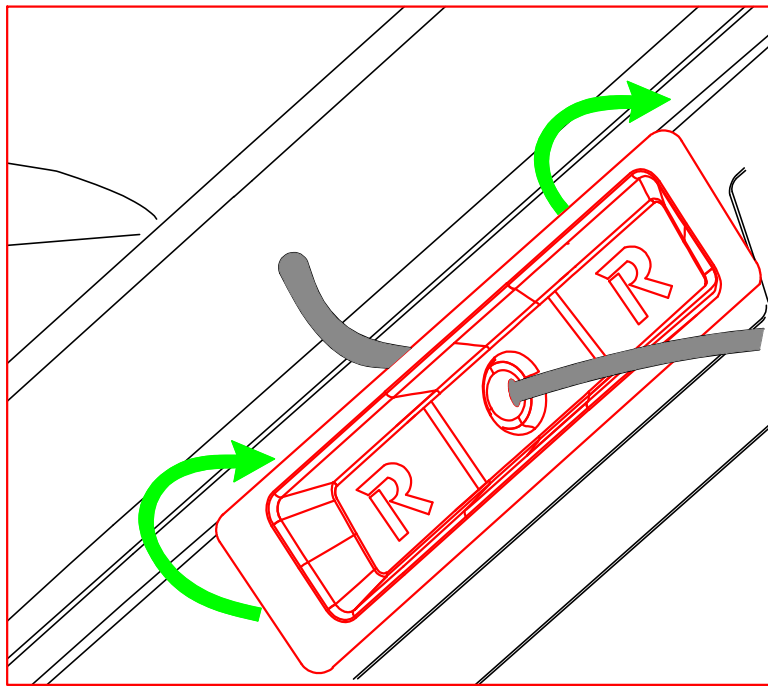

17.

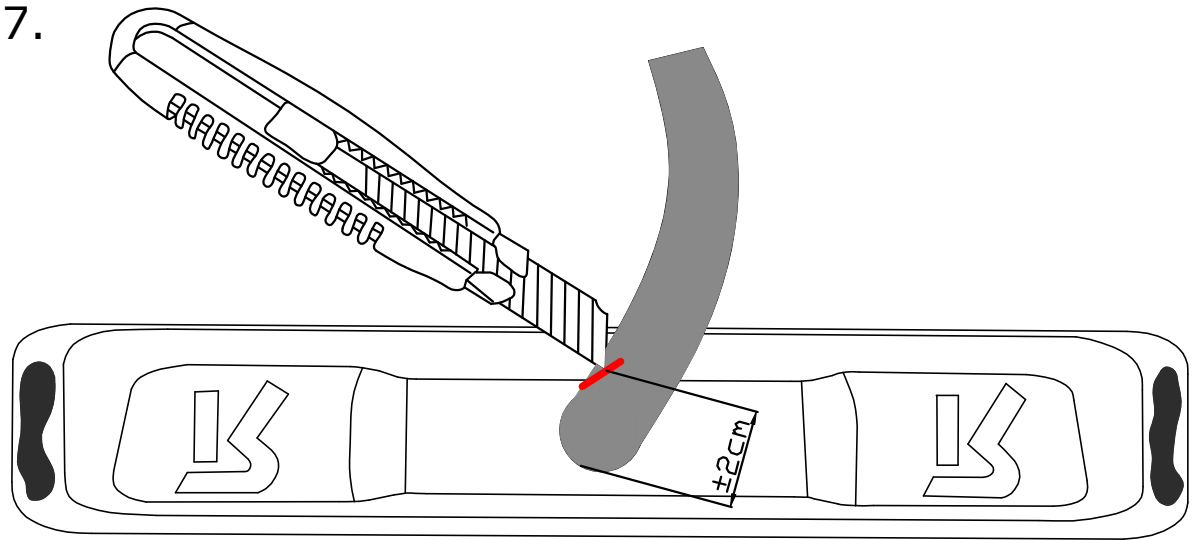

18. Installation Montage

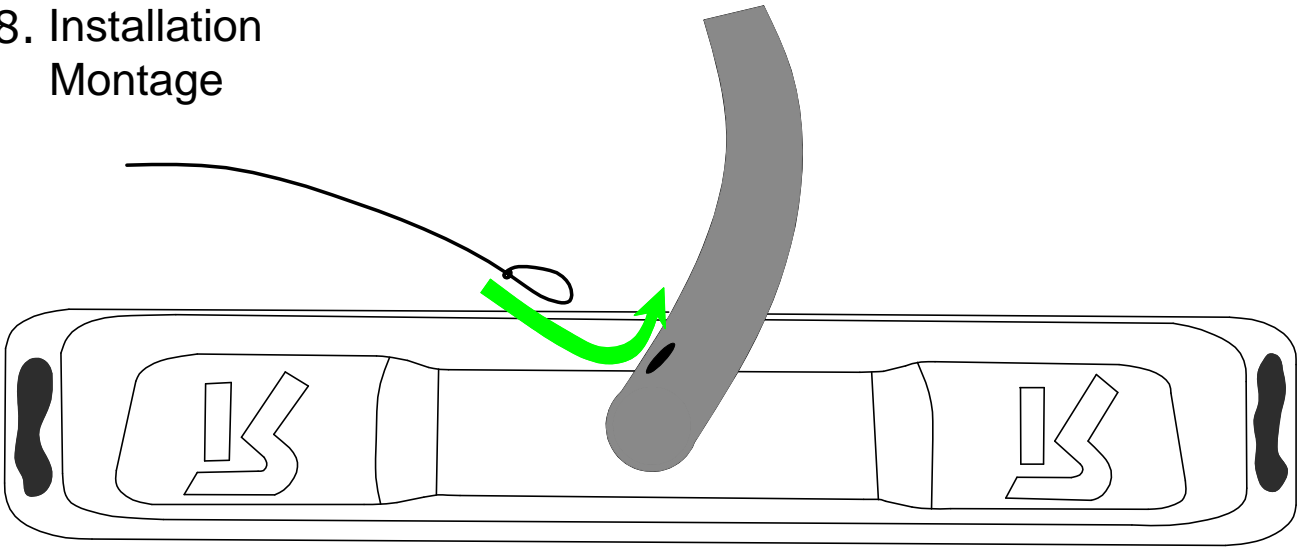

19.

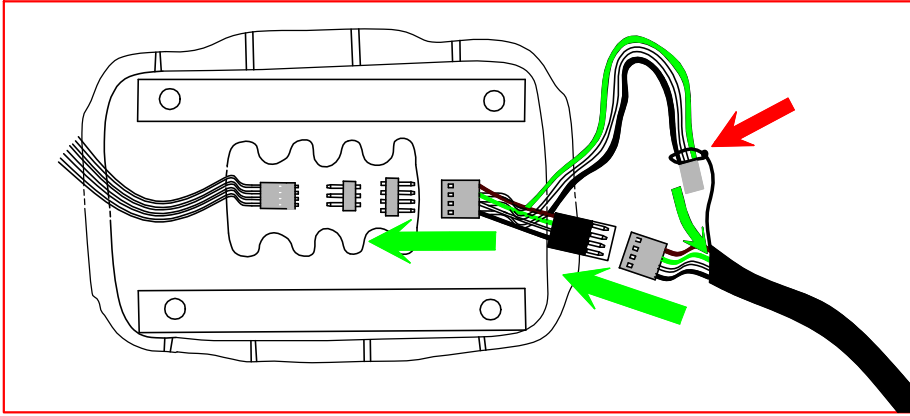

20.

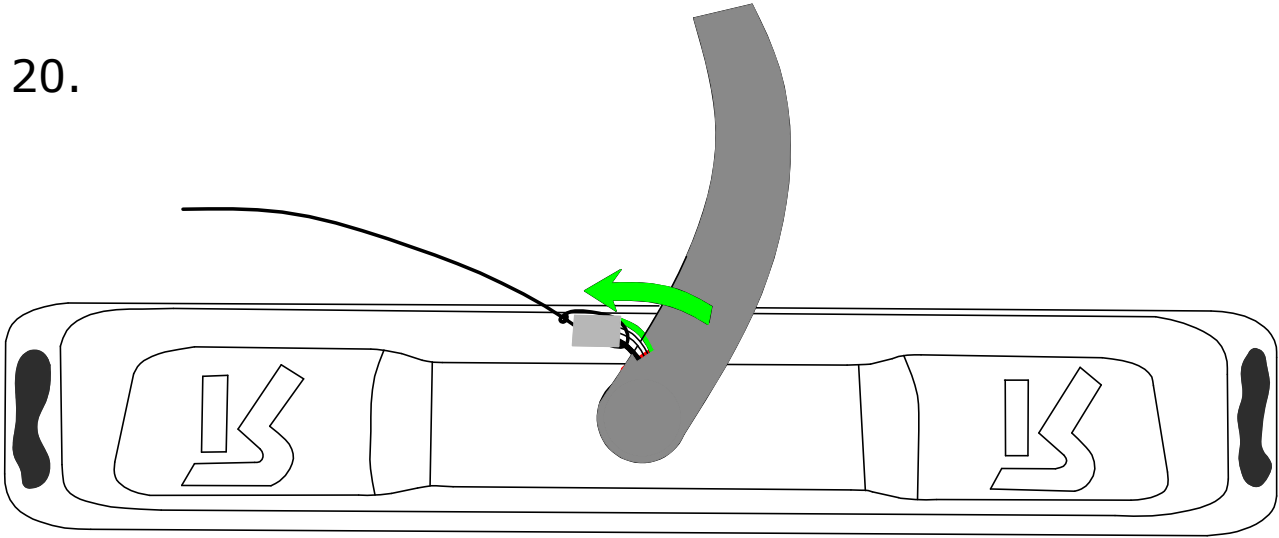

21.

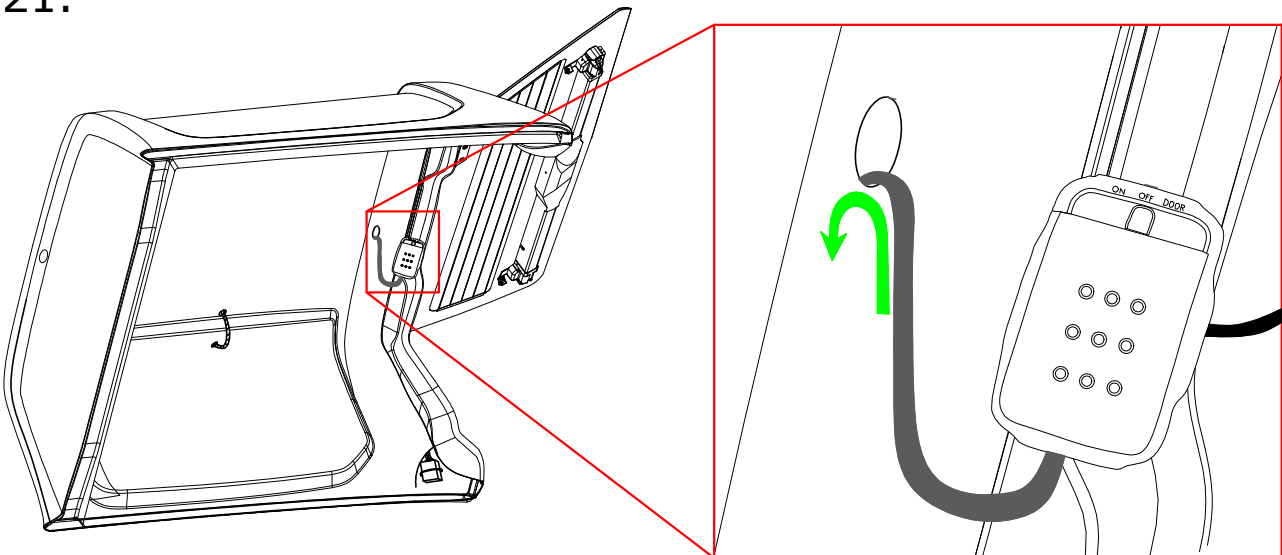

Montageanleitung >> Инструкция по установке >> Instruções de Montagem

Installation instruction >> Instruções de montagem >> Montageanleitung >> Instruções de montagem >> Montageanleitung >> Instruções de montagem

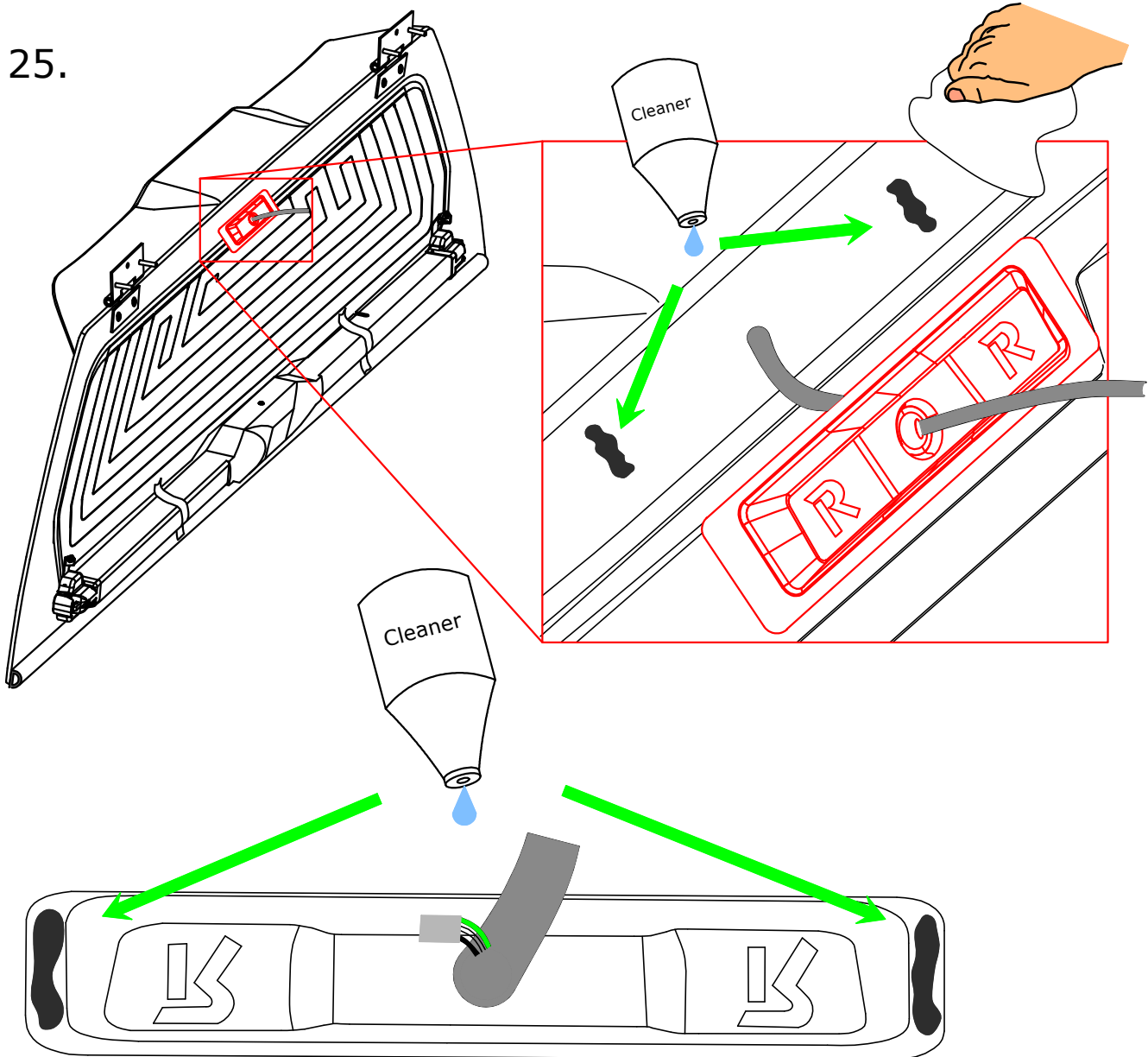
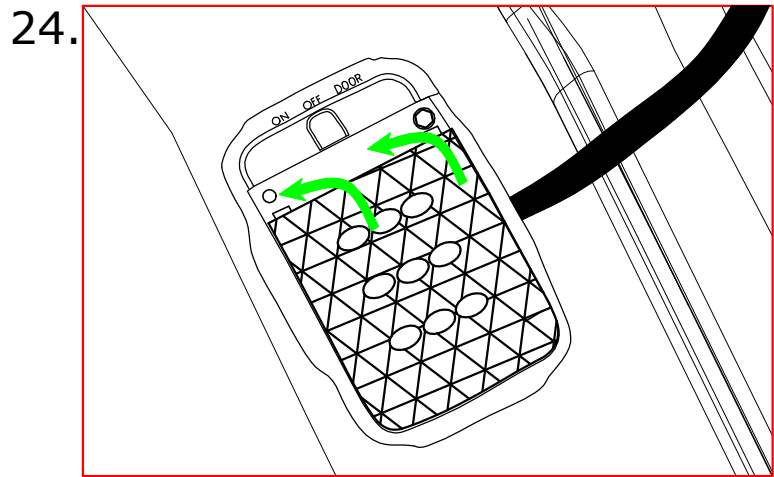
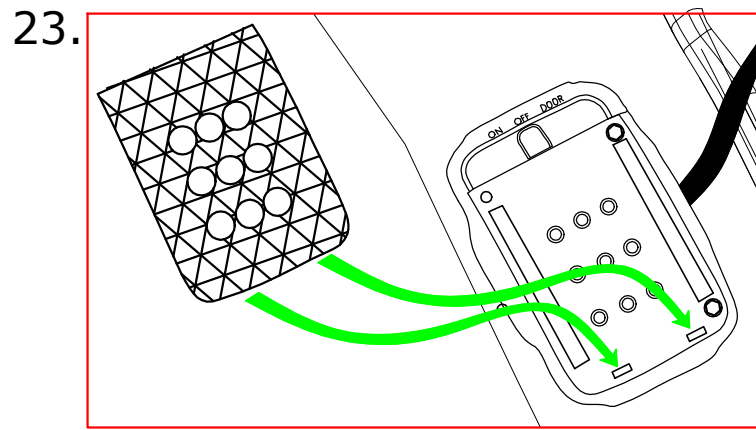
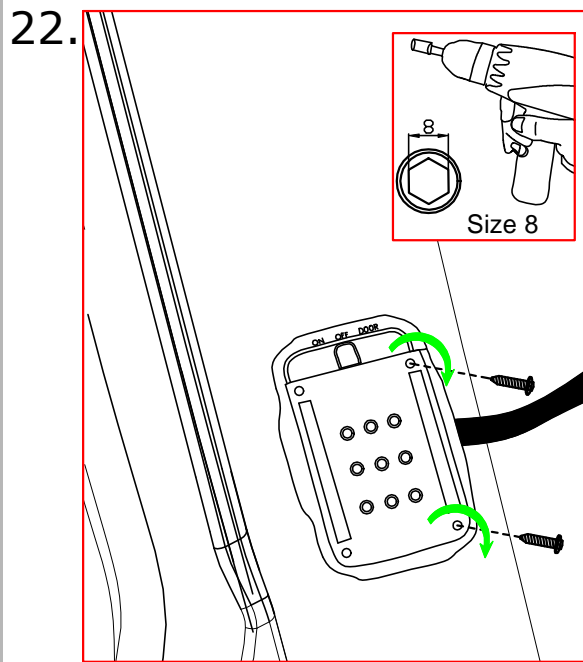

26.

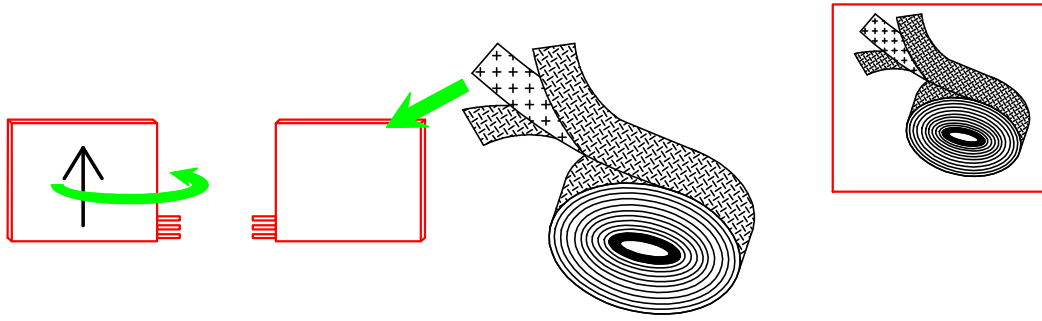

27.

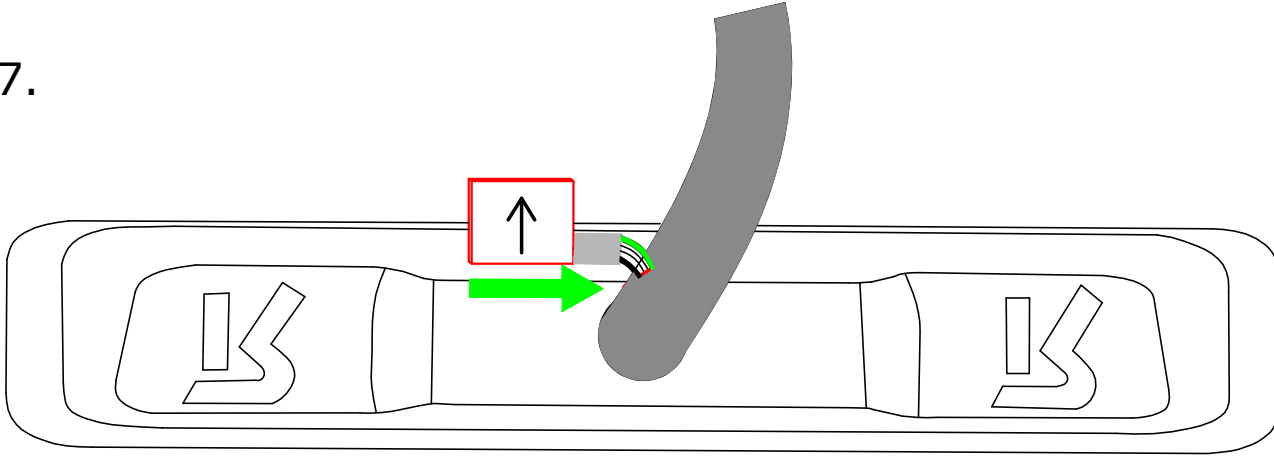

28.

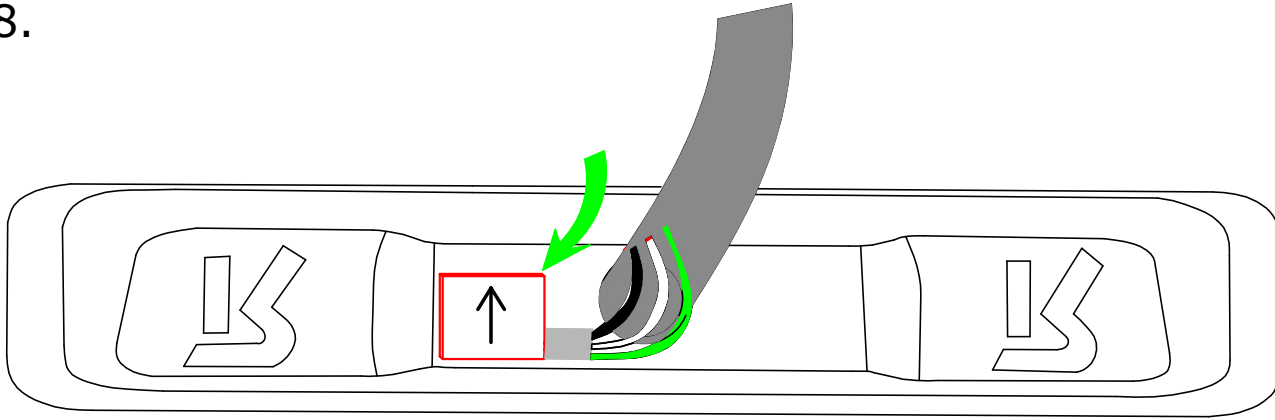

30.

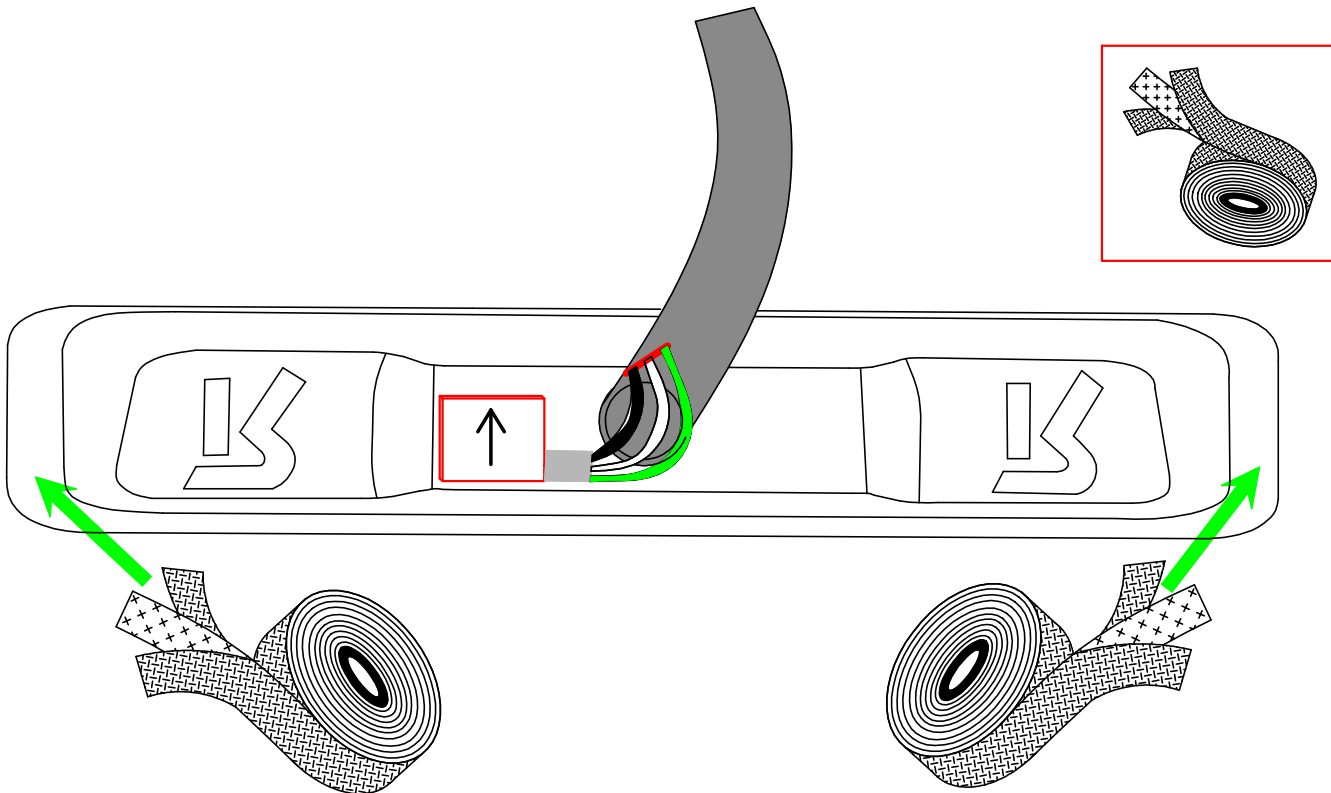

31.

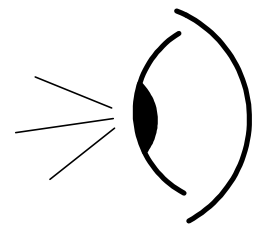
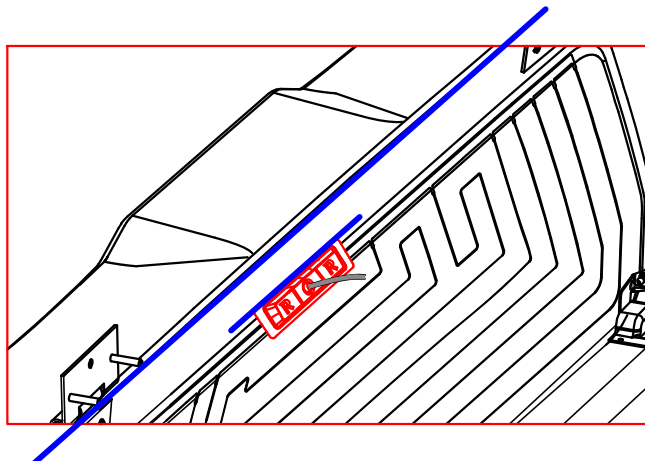
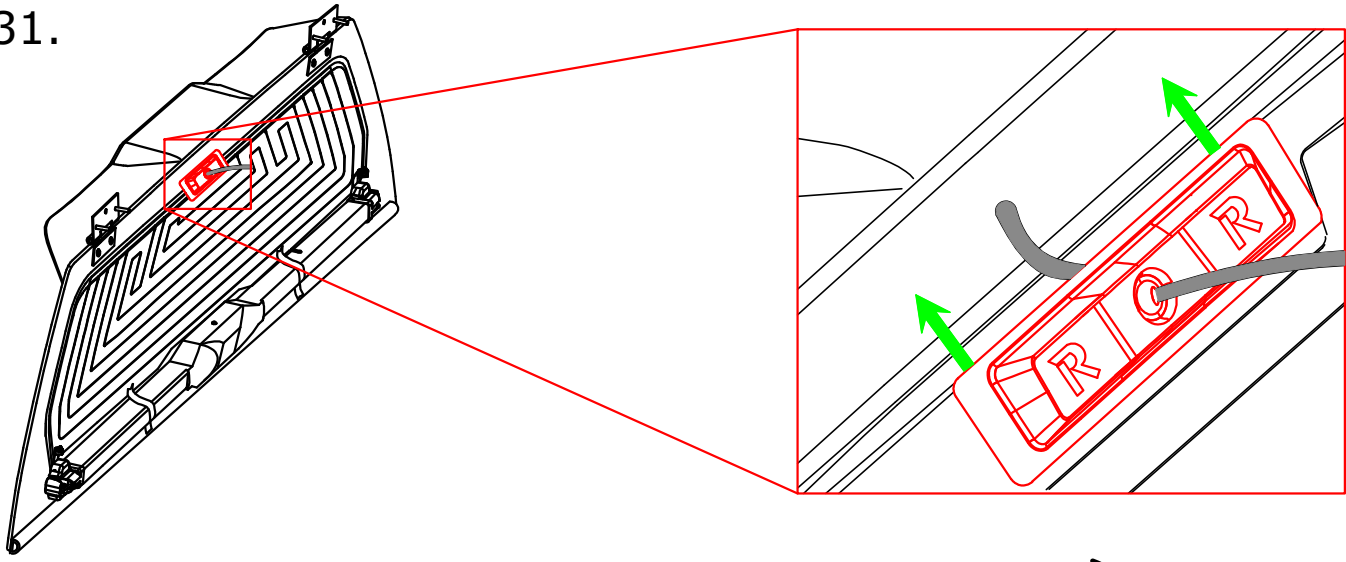

32.

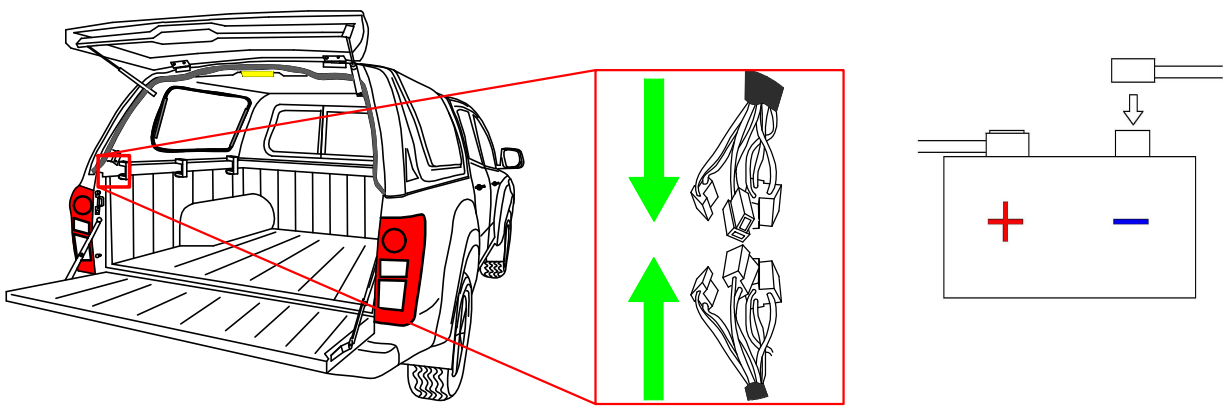

33.

