



INSTALLATION INSTRUCTIONS (K135)

Sportlid II with Proform Sportbar

Isuzu-RT50 DMax-2012/2016-Double Cab

A 1X	B L R 1X	C L R 1X	D 1X	E 2X	F M8x30mm 8X	G 2X		
H 2X	I 190N x520mm 2X	J 2X	K 2X	L M8x19mm 14X	M M8 Stainless Steel Spring Washer 14X	N T-SEAL 1220mm 1X	O 2X	P M8x20mm 4X
Q PROFORM PART 0000299 1X Refer to K307 for Sportbar assembly. Assemble bar before lid fitment	R M4 Spring Washer 2X	S Stainless steel thumb screw 2X	<p>Note 1: If at any stage of installation you find your sportlid to be an unacceptable fit please contact the manufacturer before continuing.</p> <p>Tools required: 4mm & 5mm Allen keys, 14mm Wrench</p> <p>INSTALLATION TIME APPROX: 30 Minutes</p>			Legend: ○ = NEW PART □ = 0000299 PART		
W CLEAR TAPE 35X50MM 2X	Z Sportlids Badge 1X	<p>1</p>						

Follow guide lines to trim liner in front corners.

2

Note 2: If required, use Proform Under Rail Bed Liner only. Not for use with Over Rail Bed Liner.

Ensure the mount rail is placed into the front corner of the cargo box

3

FINGER TIGHTEN ONLY

Fitting Kit Number	Manufacturer	Model Type	Year	Stockist	Cab Size	Product	Revision	Date	Page
IDFK135	Isuzu	RT50 DMax	2012/16	General Use	DC	Sportlid2	5	24-08-16	1 of 6

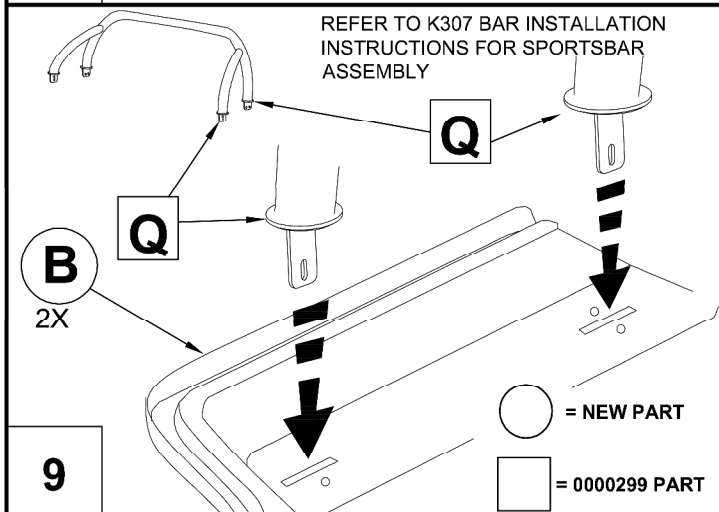
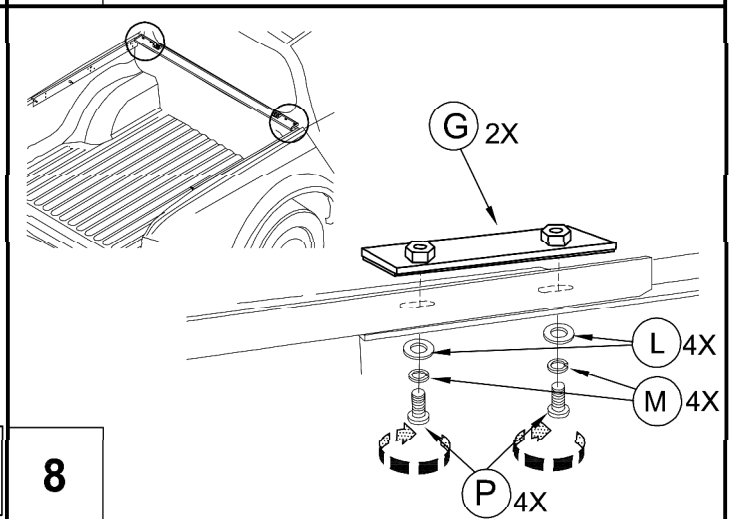
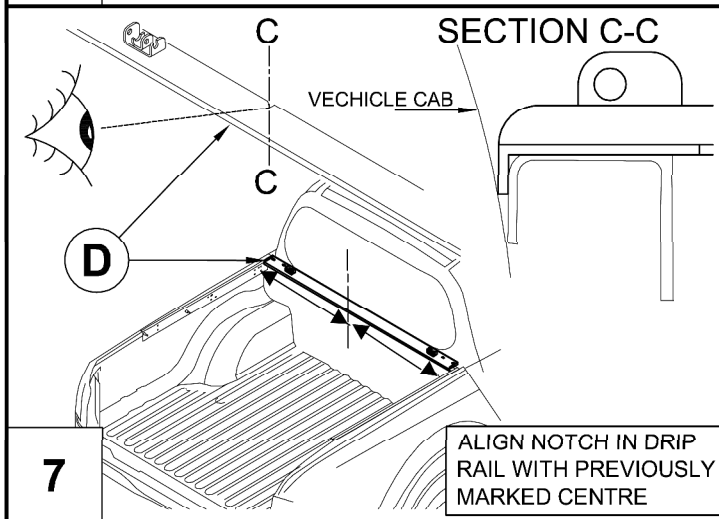
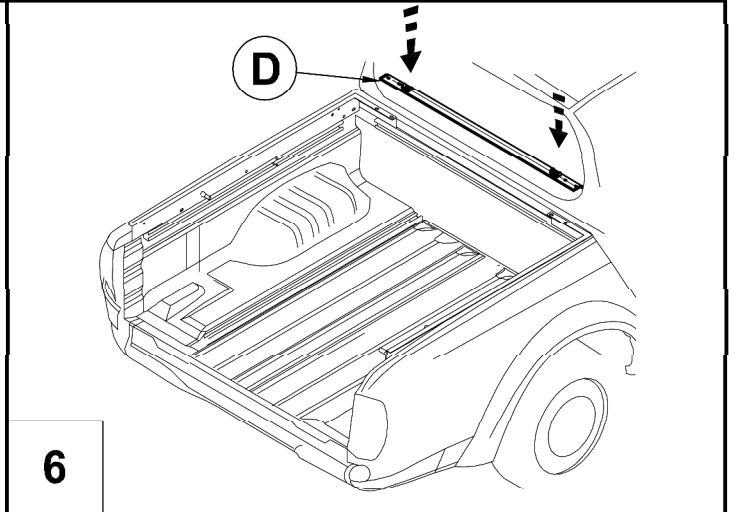
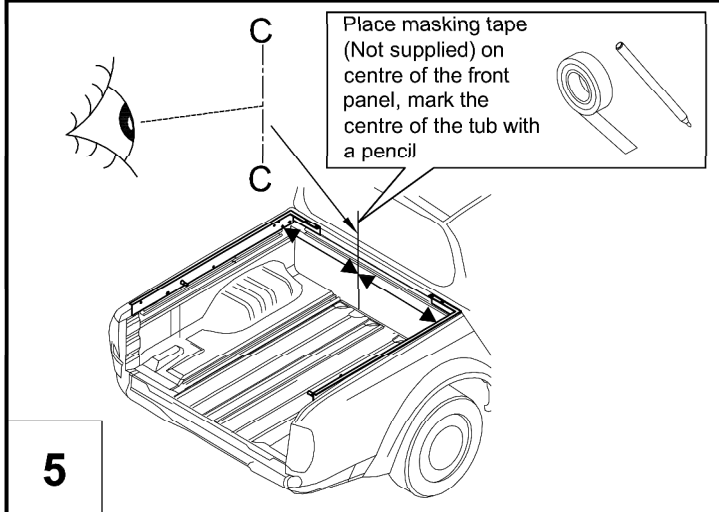
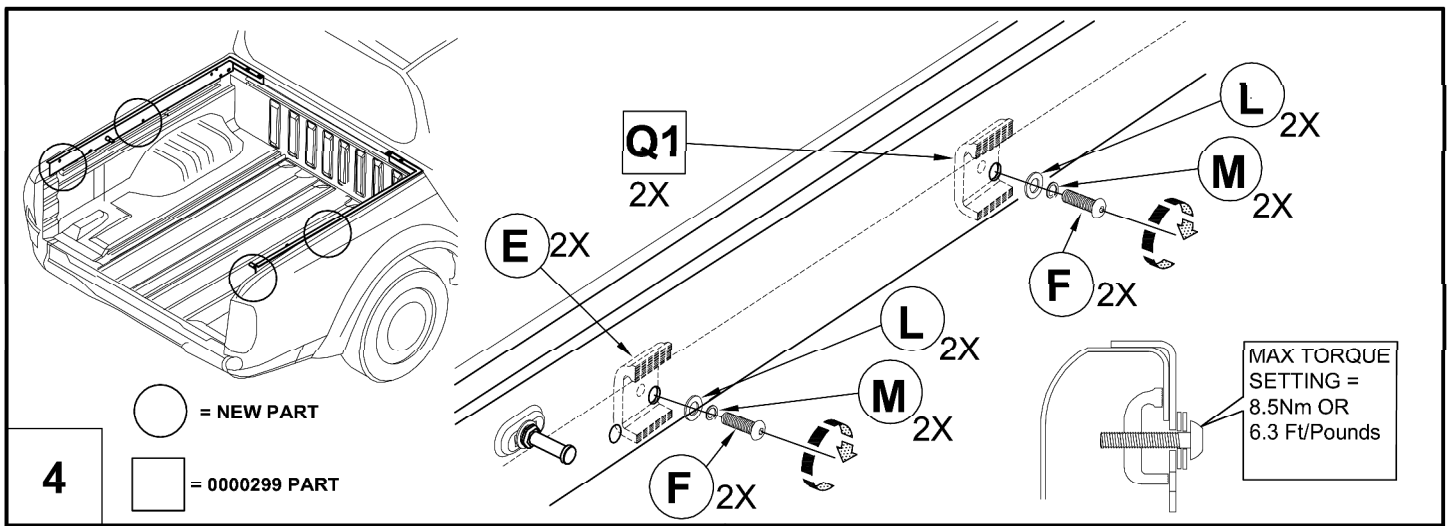

Fitting Kit Number	Manufacturer	Model Type	Year	Stockist	Cab Size	Product	Revision	Date	Page
IDFK135	Isuzu	RT50 DMax	2012/16	General Use	DC	Sportlid2	5	24-08-16	2 of 6

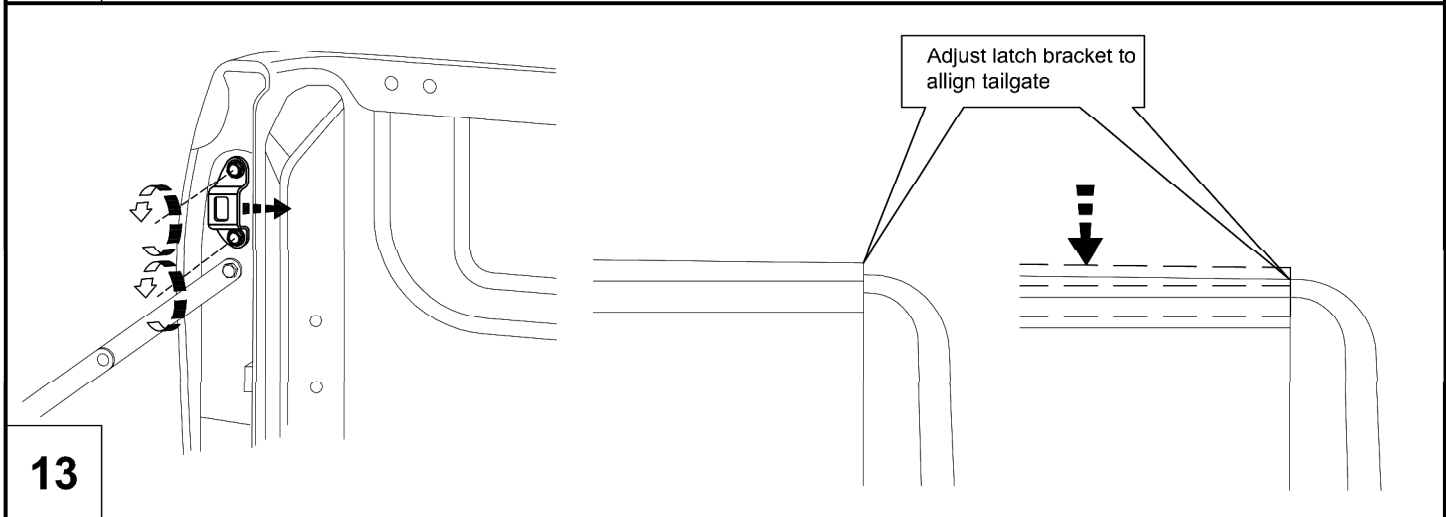
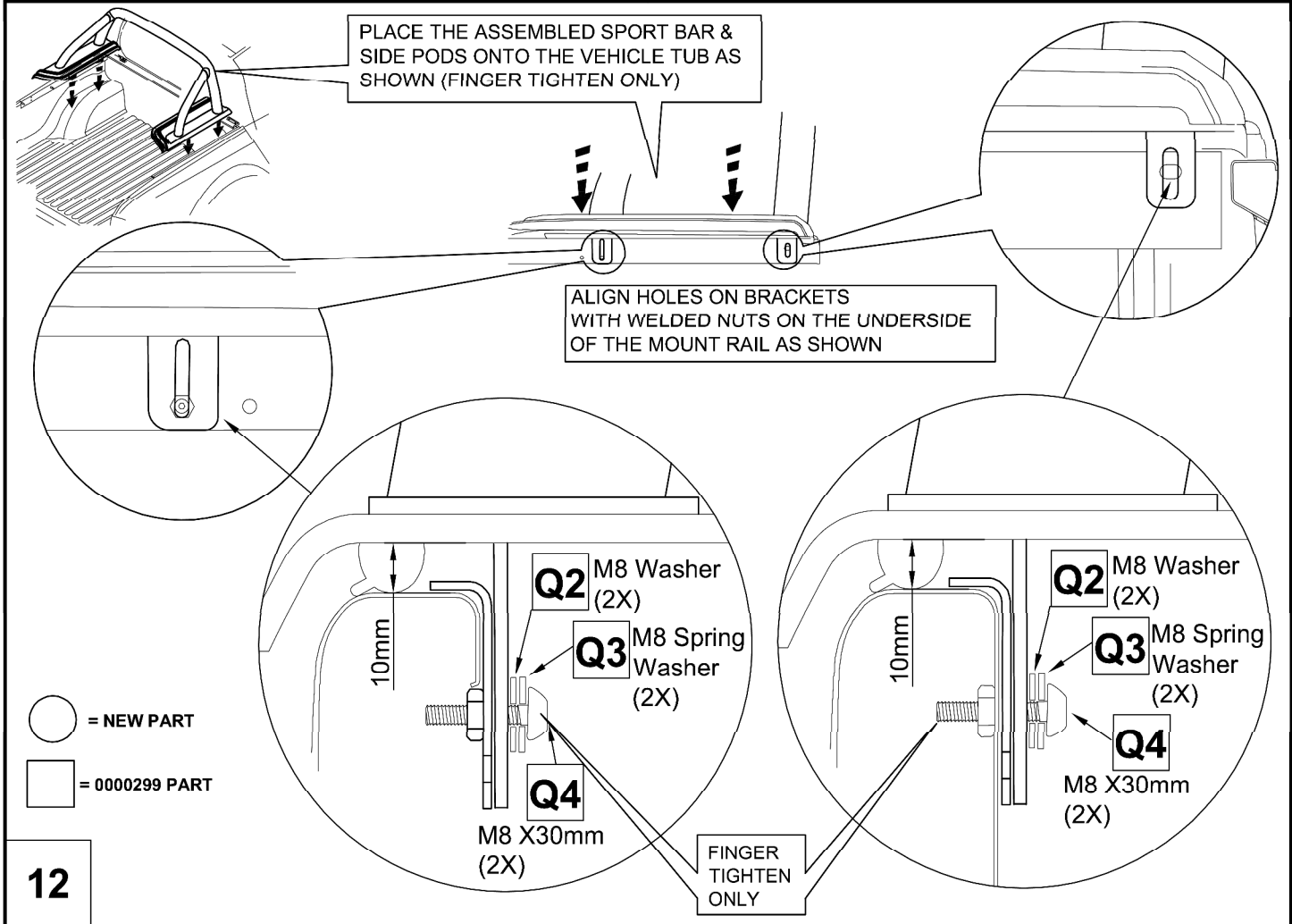
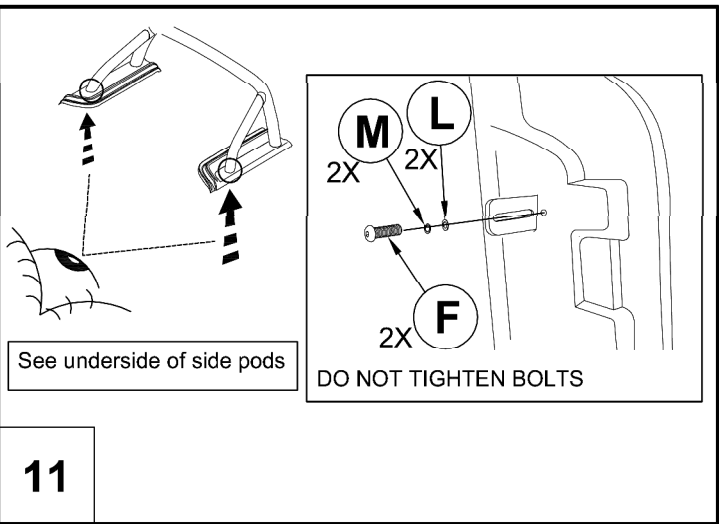
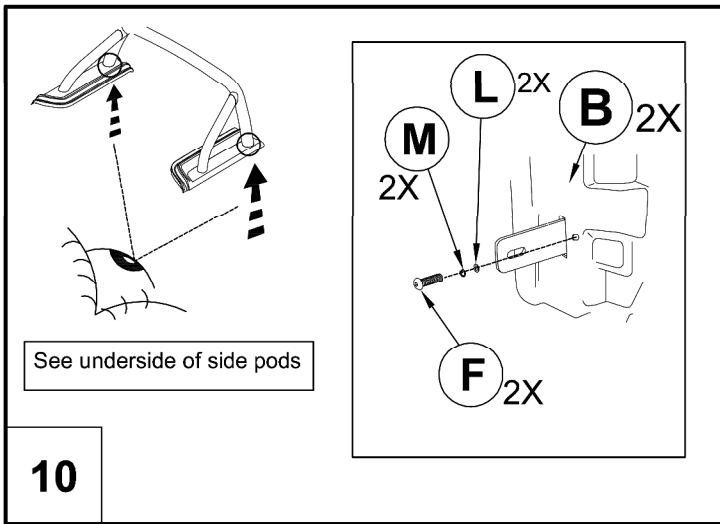

Fitting Kit Number	Manufacturer	Model Type	Year	Stockist	Cab Size	Product	Revision	Date	Page
IDFK135	Isuzu	RT50 DMax	2012/16	General Use	DC	Sportlid2	5	24-08-16	3 of 6



RAIN SEAL MUST BE APPLIED AFTER PAINT PROCESS IS COMPLETE
 DO NOT apply below 15°C.
 DO NOT stretch when applying.
 Apply pressure to seal. Adhesive is pressure activated.
 Allow 3hrs minimum to cure before fitting lid.

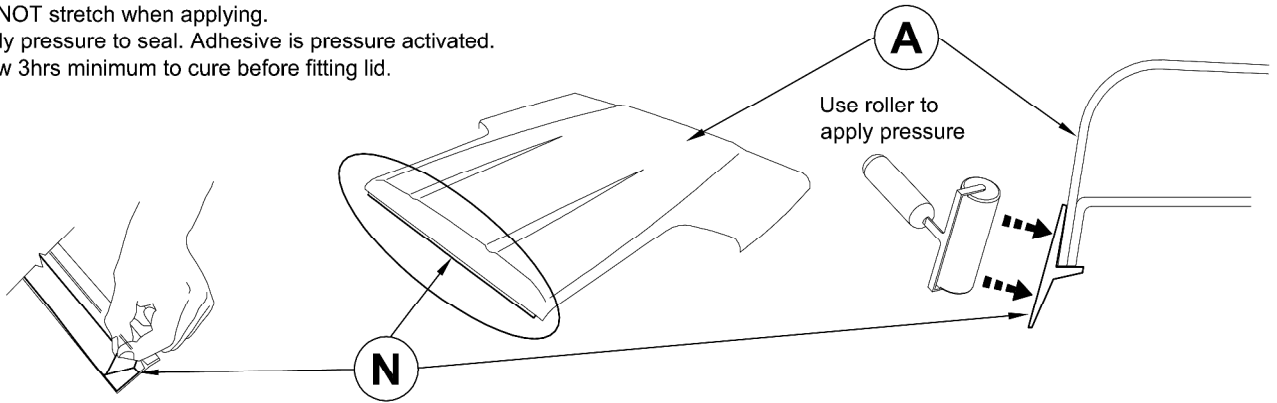

14

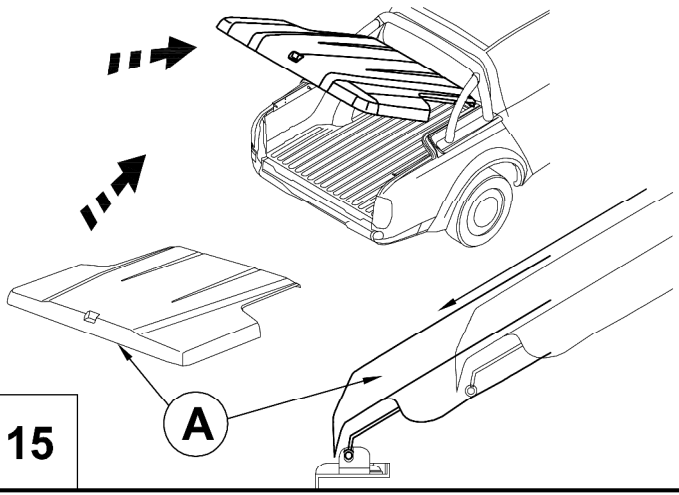

15

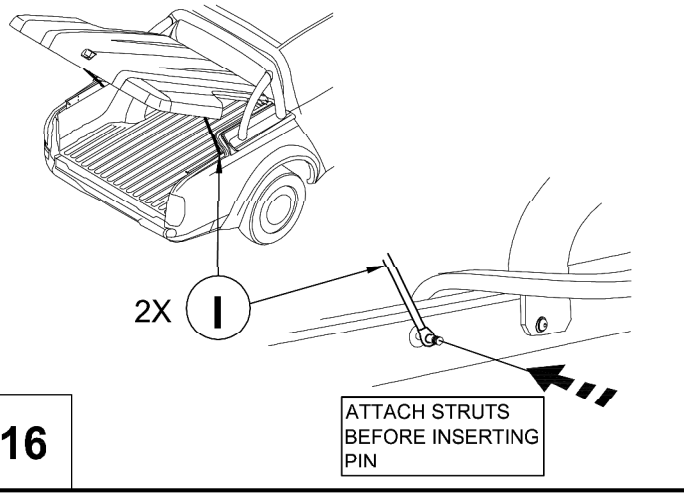

16

ATTACH STRUTS BEFORE INSERTING PIN

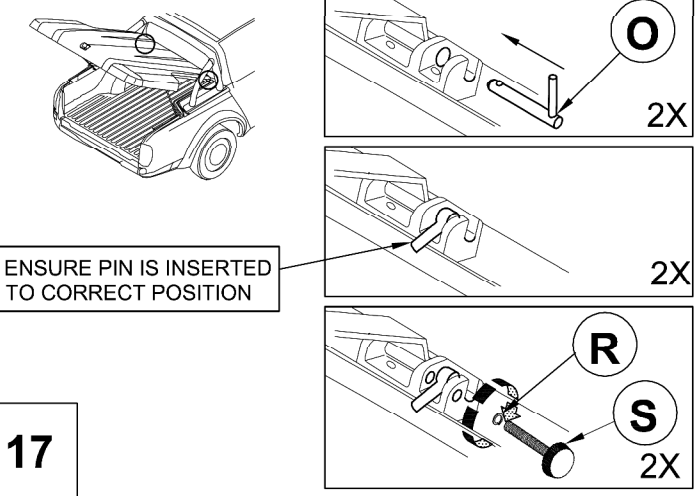

17

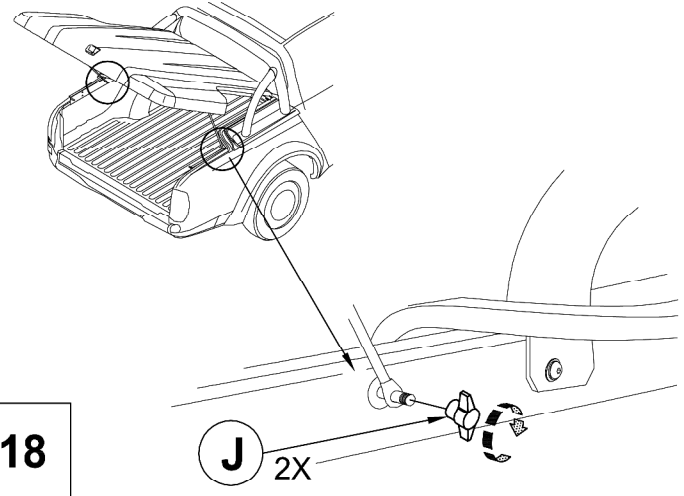

18

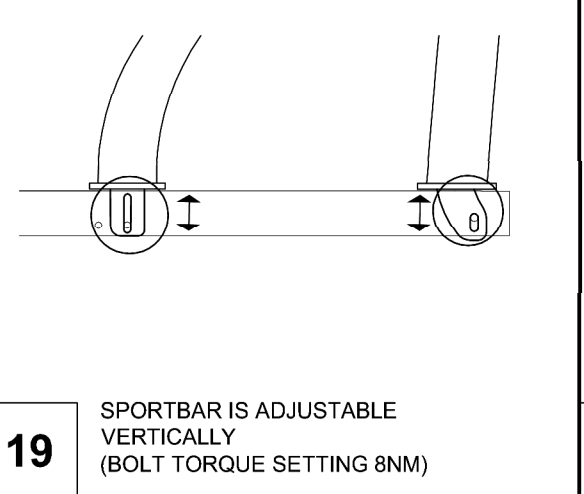

19

SPORTBAR IS ADJUSTABLE VERTICALLY (BOLT TORQUE SETTING 8NM)

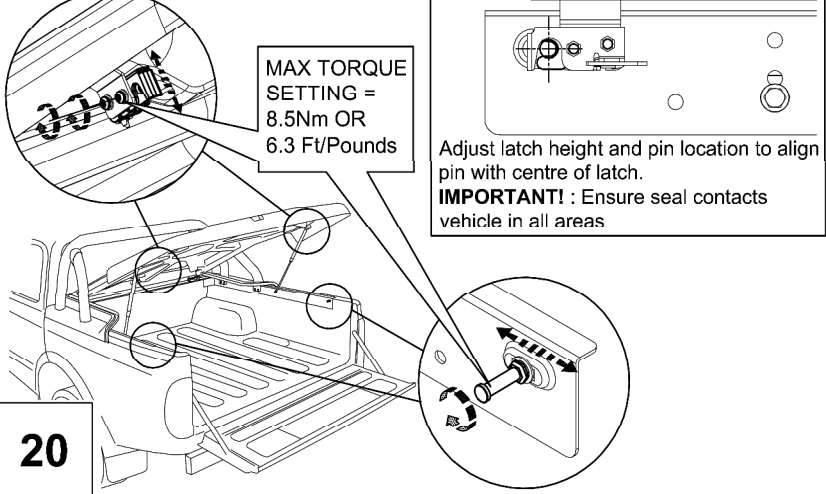

20

Fitting Kit Number	Manufacturer	Model Type	Year	Stockist	Cab Size	Product	Revision	Date	Page
IDFK135	Isuzu	RT50 DMax	2012/16	General Use	DC	Sportlid2	5	24-08-16	4 of 6

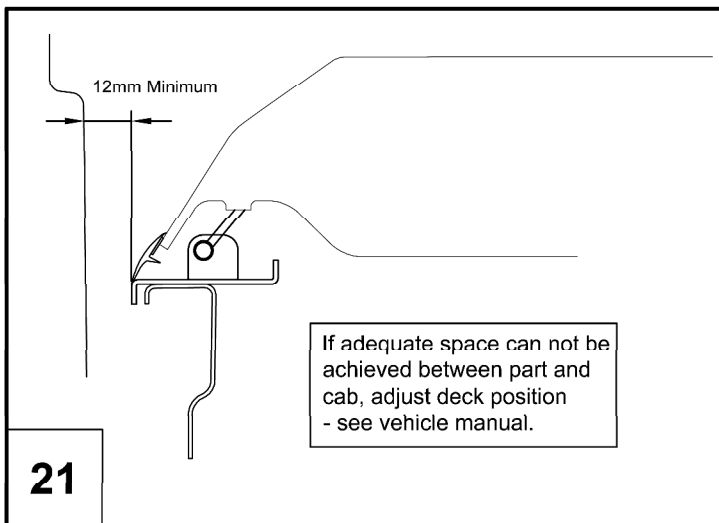

21

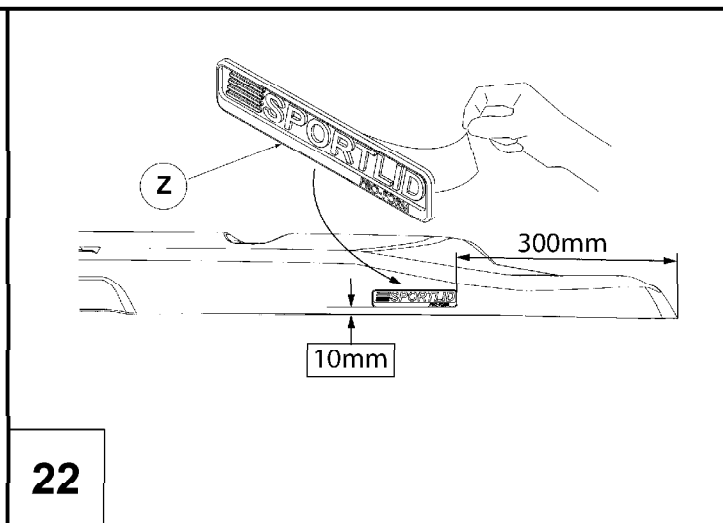

22

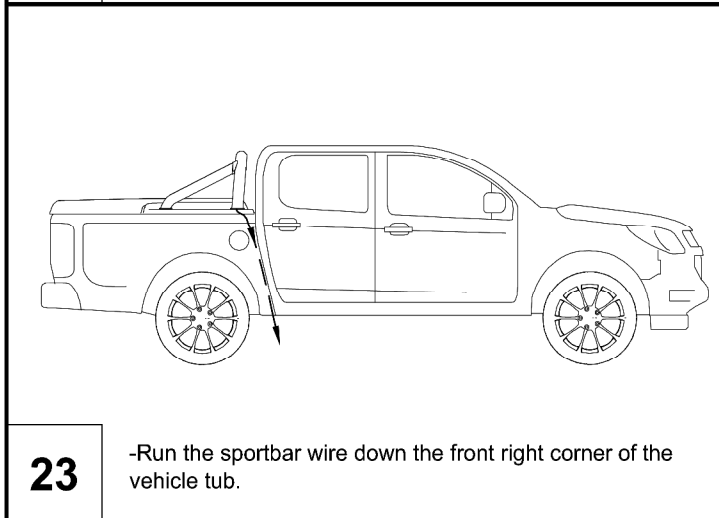

23

-Run the sportbar wire down the front right corner of the vehicle tub.

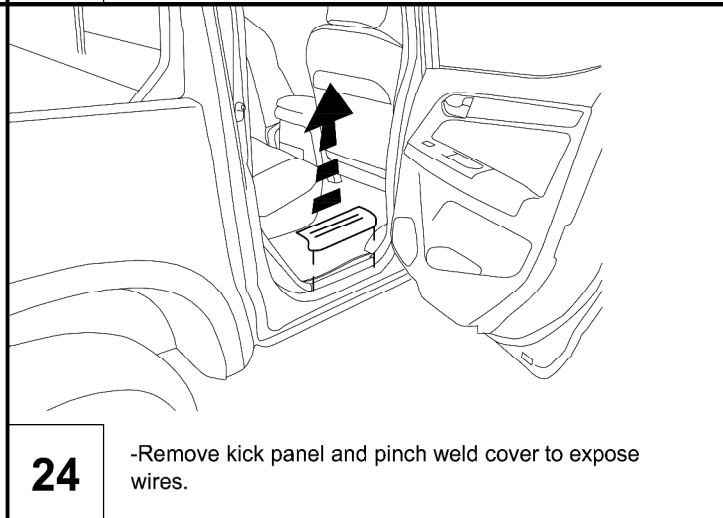

24

-Remove kick panel and pinch weld cover to expose wires.

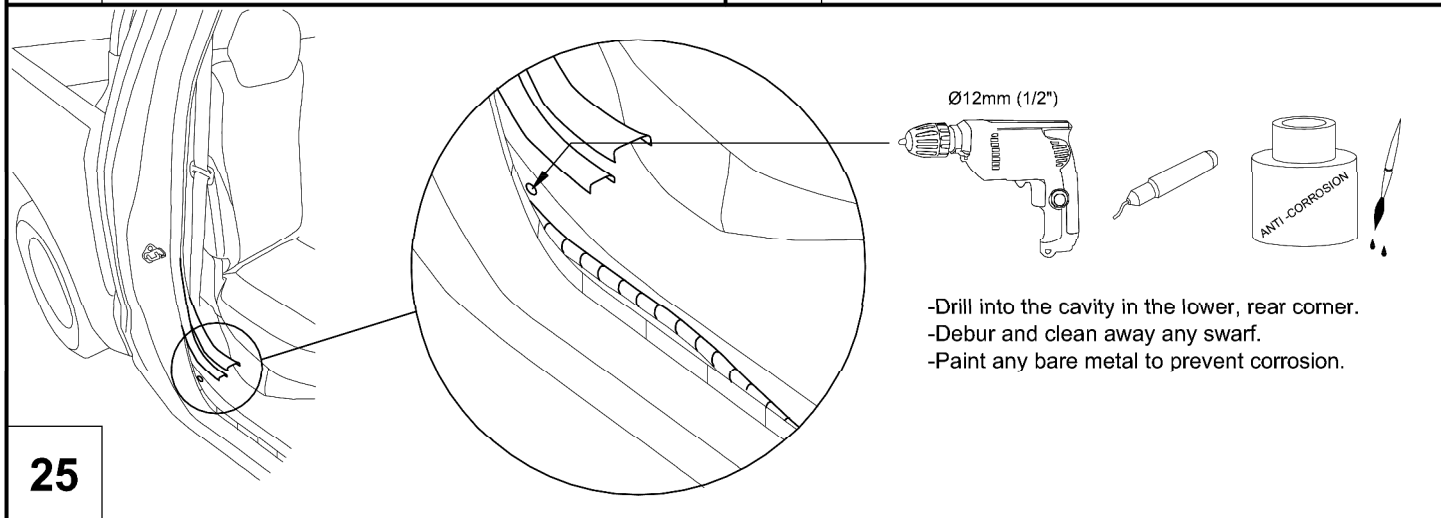

25

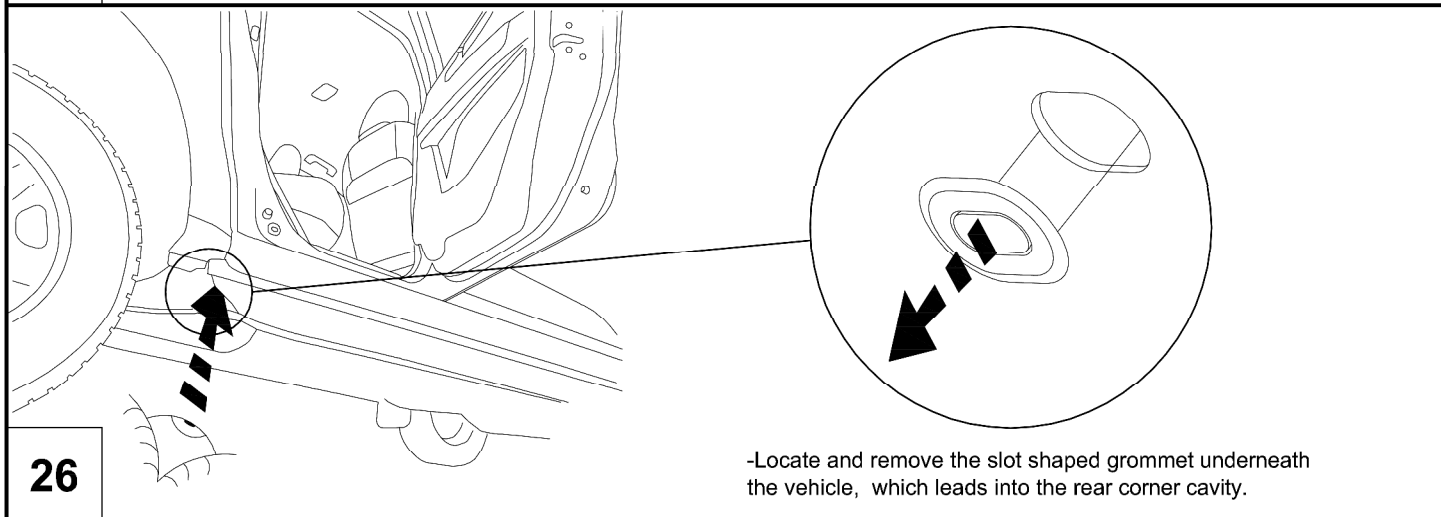

26

-Locate and remove the slot shaped grommet underneath the vehicle, which leads into the rear corner cavity.

Fitting Kit Number	Manufacturer	Model Type	Year	Stockist	Cab Size	Product	Revision	Date	Page
IDFK135	Isuzu	RT50 DMax	2012/16	General Use	DC	Sportlid2	5	24-08-16	5 of 6

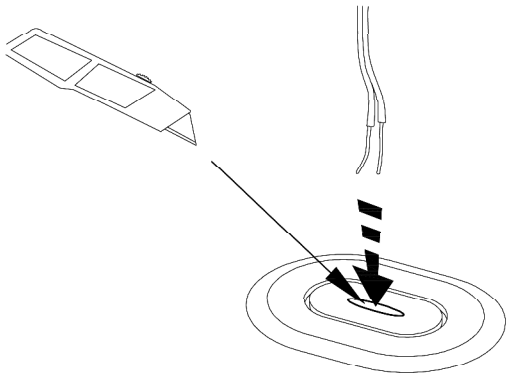

Tighten all bolts to torque settings stated.
Retain these instructions for future reference.

27 -Cut a small hole to feed the sportbar brake light wire through

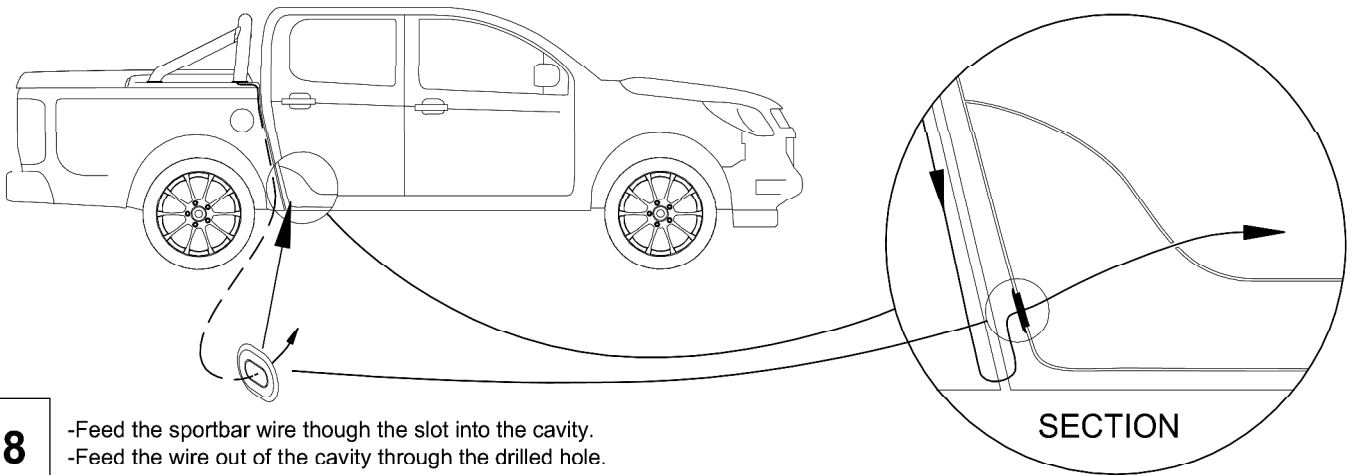

28 -Feed the sportbar wire through the slot into the cavity.
-Feed the wire out of the cavity through the drilled hole.

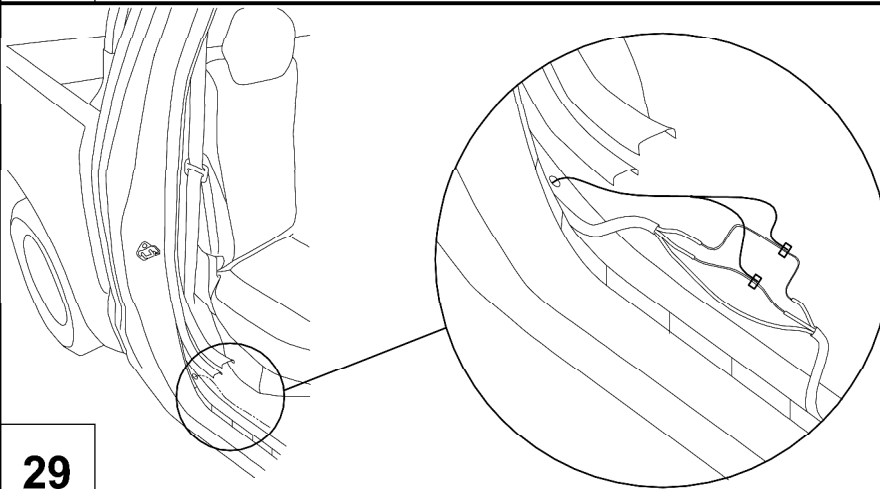

-Locate the high mount stoplight power and earth wire.
-Double check all wires to ensure the seat belt pre-tensioners or interior light are not disrupted.
-Scotch lock the required wires together.

29

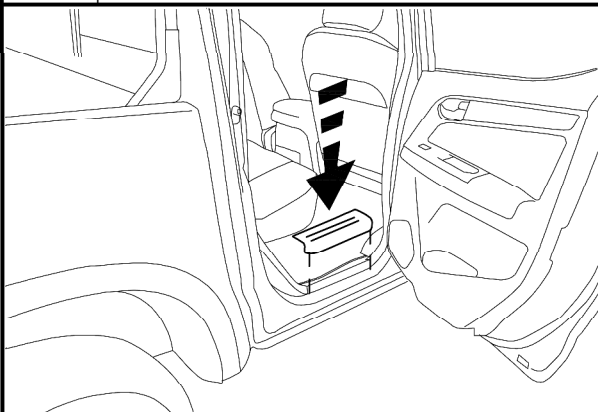

30 -Test to ensure correct installation.
-Replace kick panel and pinch weld cover.

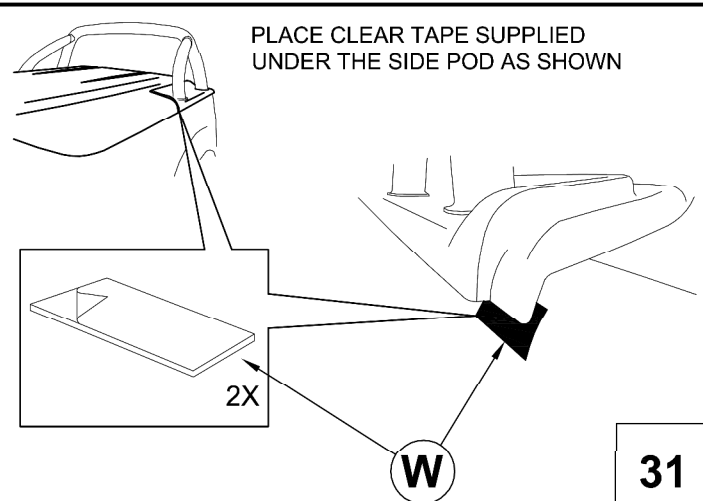

PLACE CLEAR TAPE SUPPLIED UNDER THE SIDE POD AS SHOWN

31

Fitting Kit Number	Manufacturer	Model Type	Year	Stockist	Cab Size	Product	Revision	Date	Page
IDFK135	Isuzu	RT50 DMax	2012/16	General Use	DC	Sportlid2	5	24-08-16	6 of 6