

NISSAN NAVARA ('05-)

-
- ✳ **Enganche fabricado por URBENI adaptable a la marca del vehículo.**
 - ✳ **Towbar made by URBENI adaptable to the brand of the vehicle.**
 - ✳ **Attelage fabriqué par URBENI adaptable à la marque de ce véhicule.**
 - ✳ **Für dieses Fahrzeug angepasst und hergestellt durch URBENI**
 - ✳ **Dispositivo de traino URBENI adeguato alla marca di questo veicolo.**

URBENI le ofrece una garantía del producto por un periodo de 2 años desde la fecha de entrega. conforme lo dispuesto en la directiva 1999/44/CE y la ley 23/2003, esta garantía está limitada a reemplazar el producto defectuoso y en ningún caso se extenderá a daños o perjuicios consecuenciales.

THE URBENI's products have a warranty period of 2 years after the delivery date, conform to the standard 1999/44/CE, this warranty is limited to the replacement of the defective products, and it will not never cover any private damages.

Les produits d'URBENI ont une garantie de 2 ans depuis la date de livraison ce qui est conforme à la Normative Européenne 1999/44CE. Cette garantie inclue de remplacer le produit défectueux, mais en aucun cas les dommages ou préjudices conséquents

URBENI gewährt eine Garantie von einen 2 Jahre in ordnung nach dem Fertigungsnorm. Der Hersteller behält sich das Recht vor die schadhafte Ware zu repaieren oder zu ersetzen und in keinem Fall übernimmt er Folgekosten für Schäden an Dritten.

Bemerkung: Für einen Mangel am Produkt, der durch den Fahrzeughalter oder eine andere. Person aufgrund unsachgemäßer Benutzung verursacht wurde, übernimmt Urbeni keine Haftung. Alle befestigungsschrauben der KmH nach ca. 1000 Anhänger-Km und bei jeder Fahrzeuginspektion gemäss den angegebenen Anziehdrehmomenten nachziehen

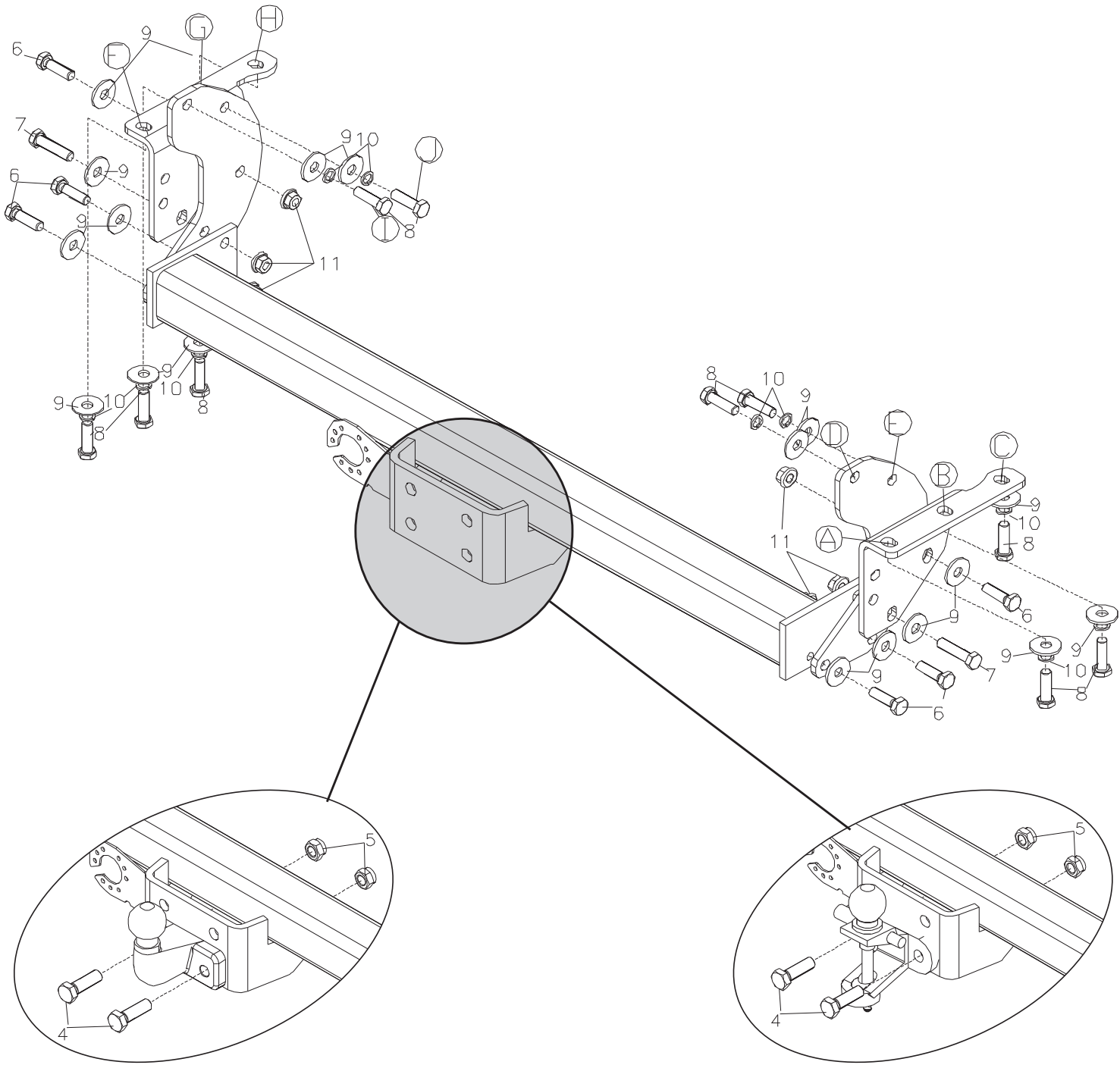

REF: 02356

URBENI

CLASS **F**

e13 APPROVAL NUMBER
00*2262

TYPE **N 019**

D- VALUE
D **15,20** kN

MAX.VERT.LOAD.
S **150** kg

www.urbeni.com
MADE IN SPAIN

REF: 12356

URBENI

CLASS **F**







e13 APPROVAL NUMBER
00*2262

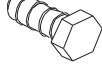
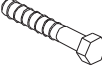
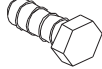

TYPE **N 019**

D- VALUE
D **15,20** kN

MAX.VERT.LOAD.
S **150** kg

www.urbeni.com
MADE IN SPAIN

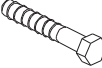
N°		Q	
1		1	
2		1	
3		1	
6		6	M12x40 DIN 933
7		2	M12x50 DIN 931
8		10	M12x1,25x40 DIN 931
9		18	M12 DIN 9021
10		12	M12 DIN 7980
11		7	M12 DIN 6923

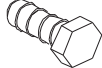
			
4		2	M16x50 DIN 931
5		2	M16 DIN 985
12		1	M12x30 DIN 933

1

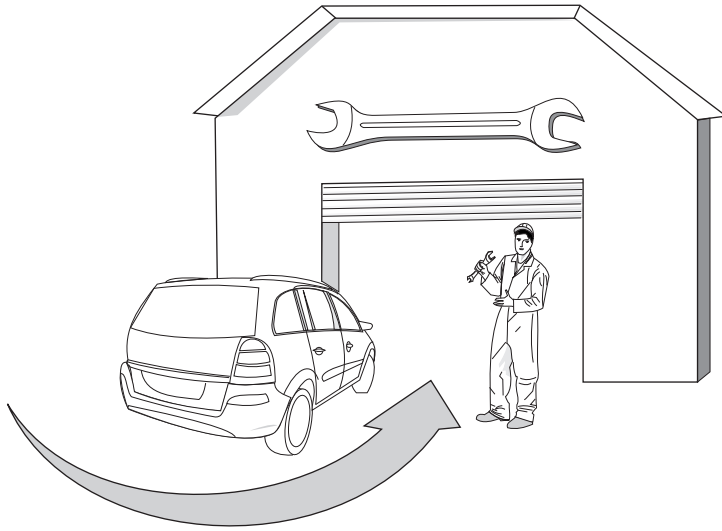

2

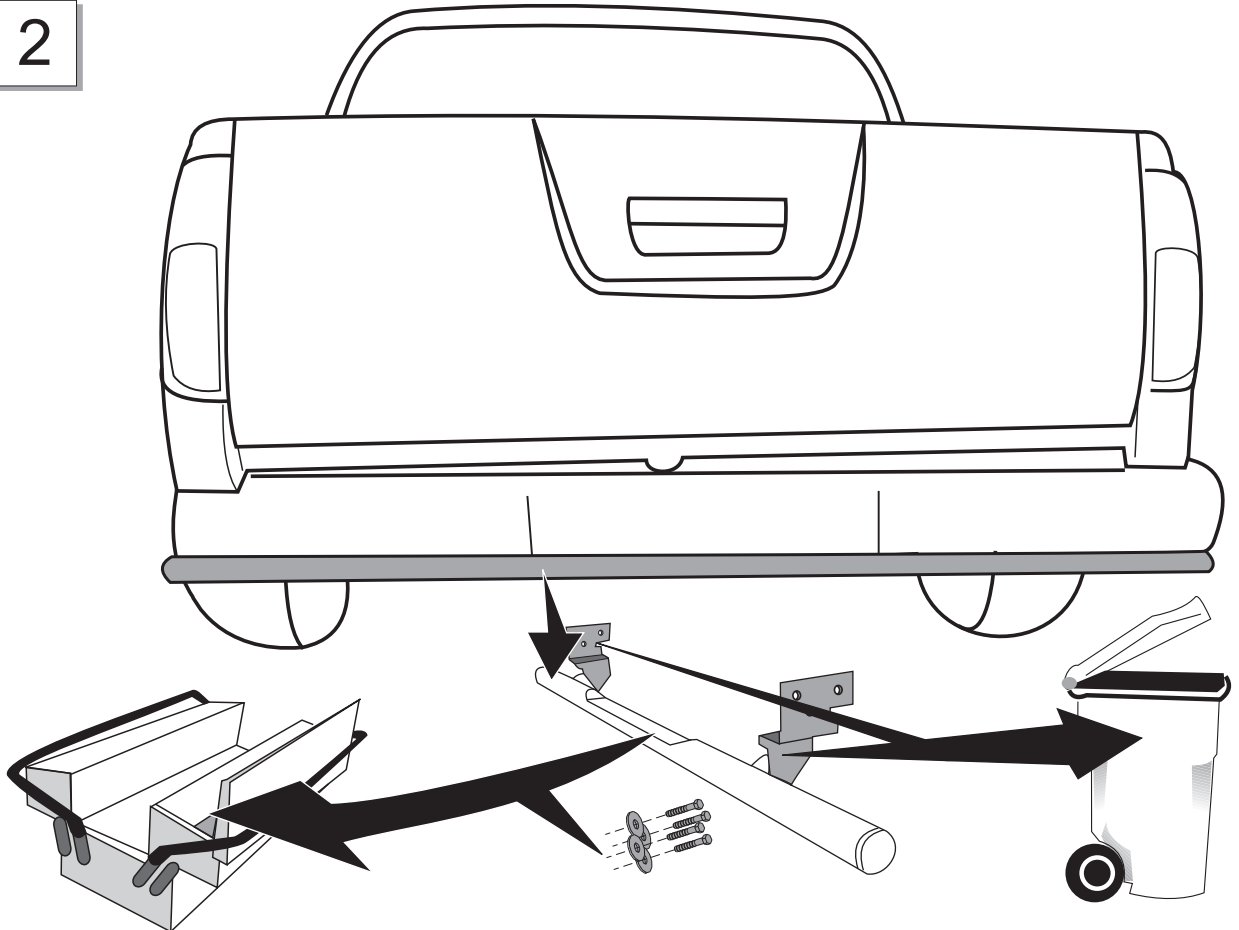

3

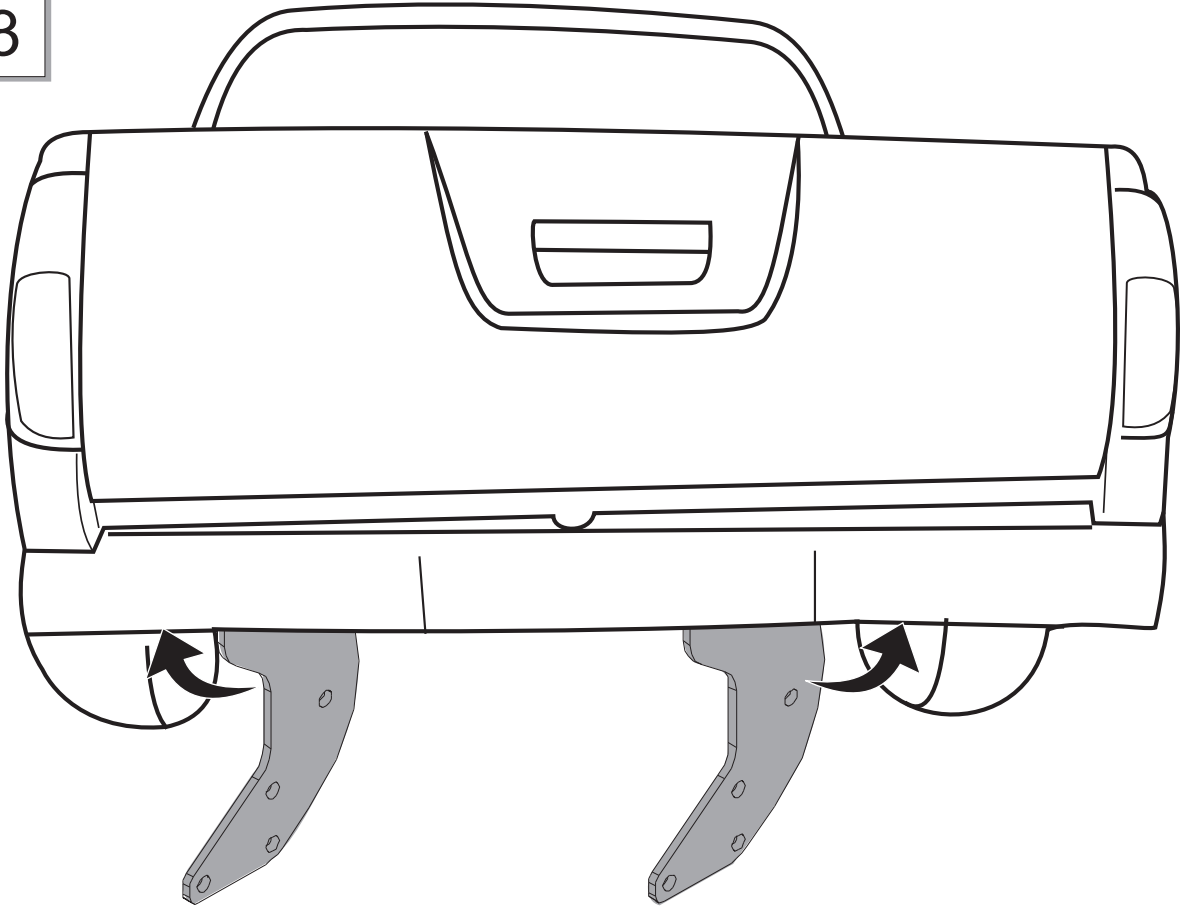

4

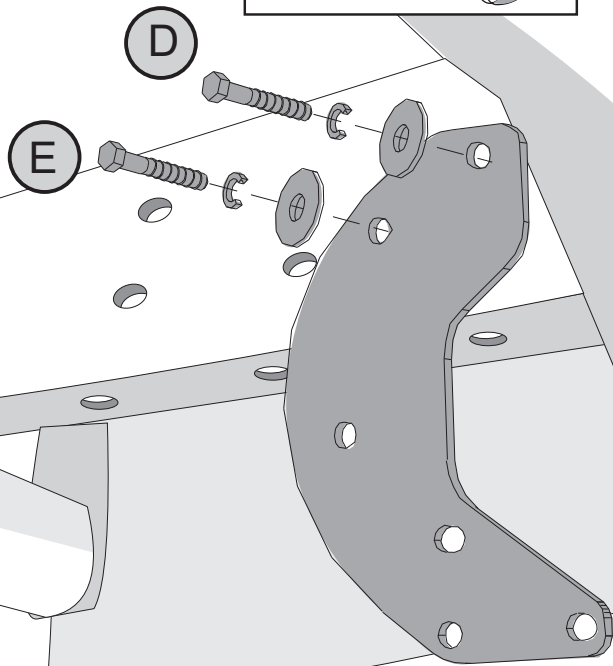
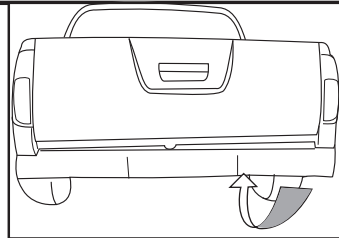

5

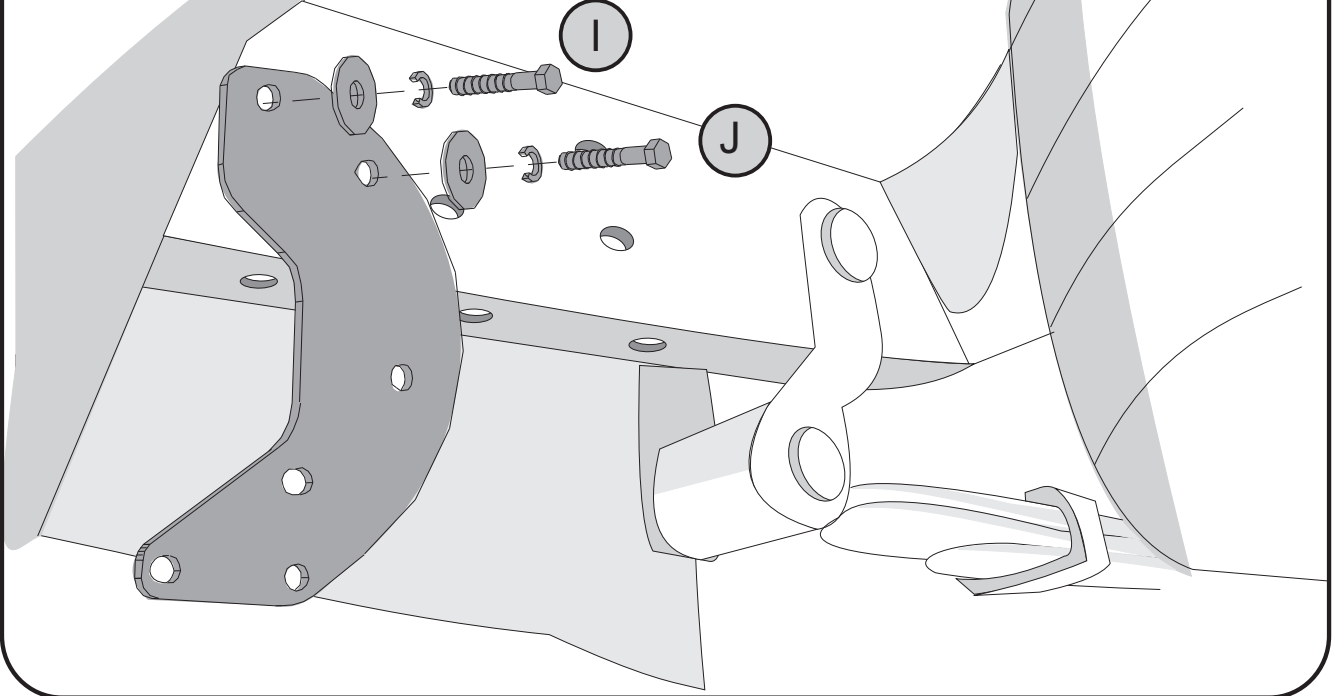
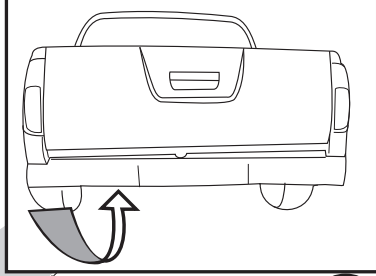

6

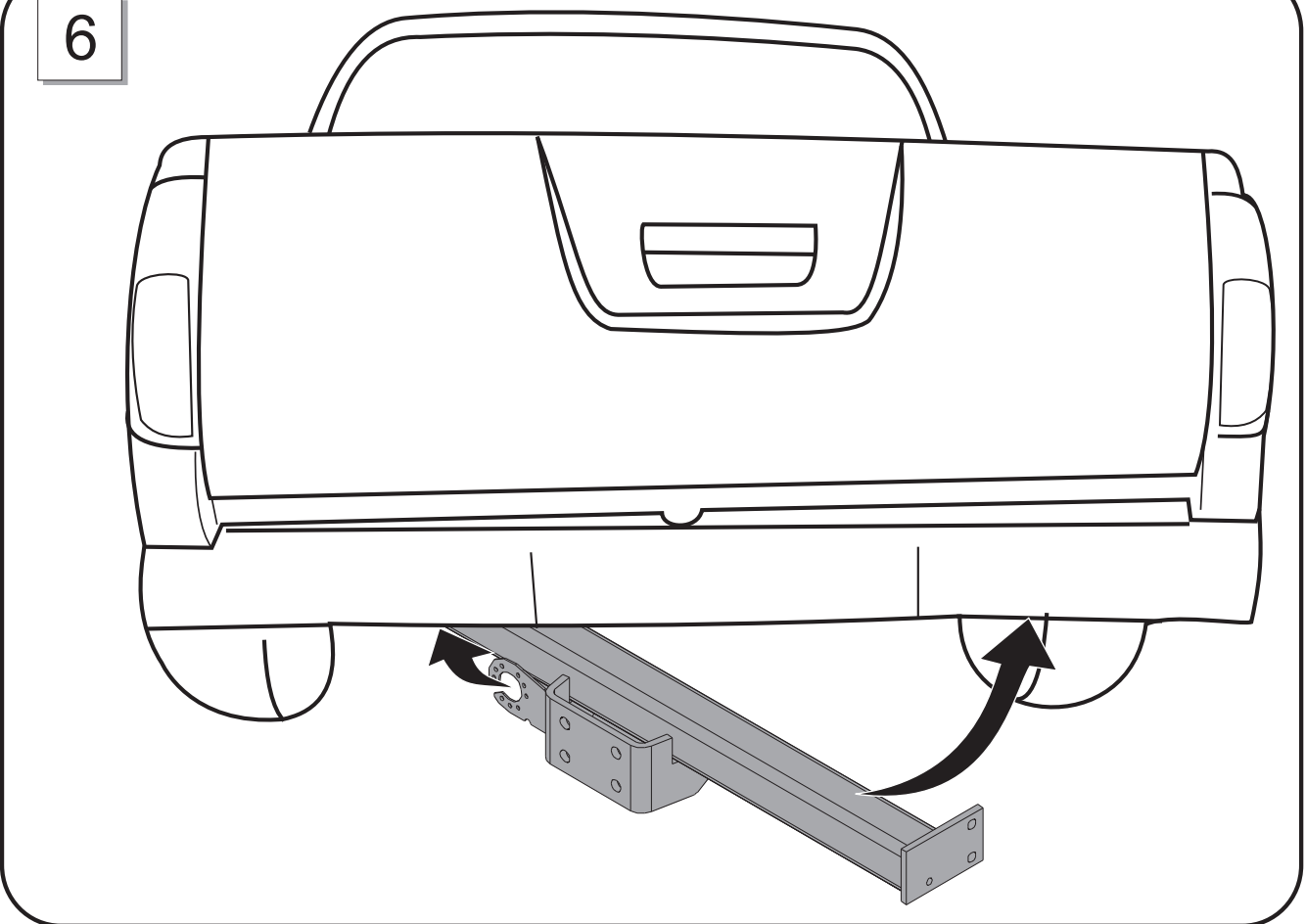

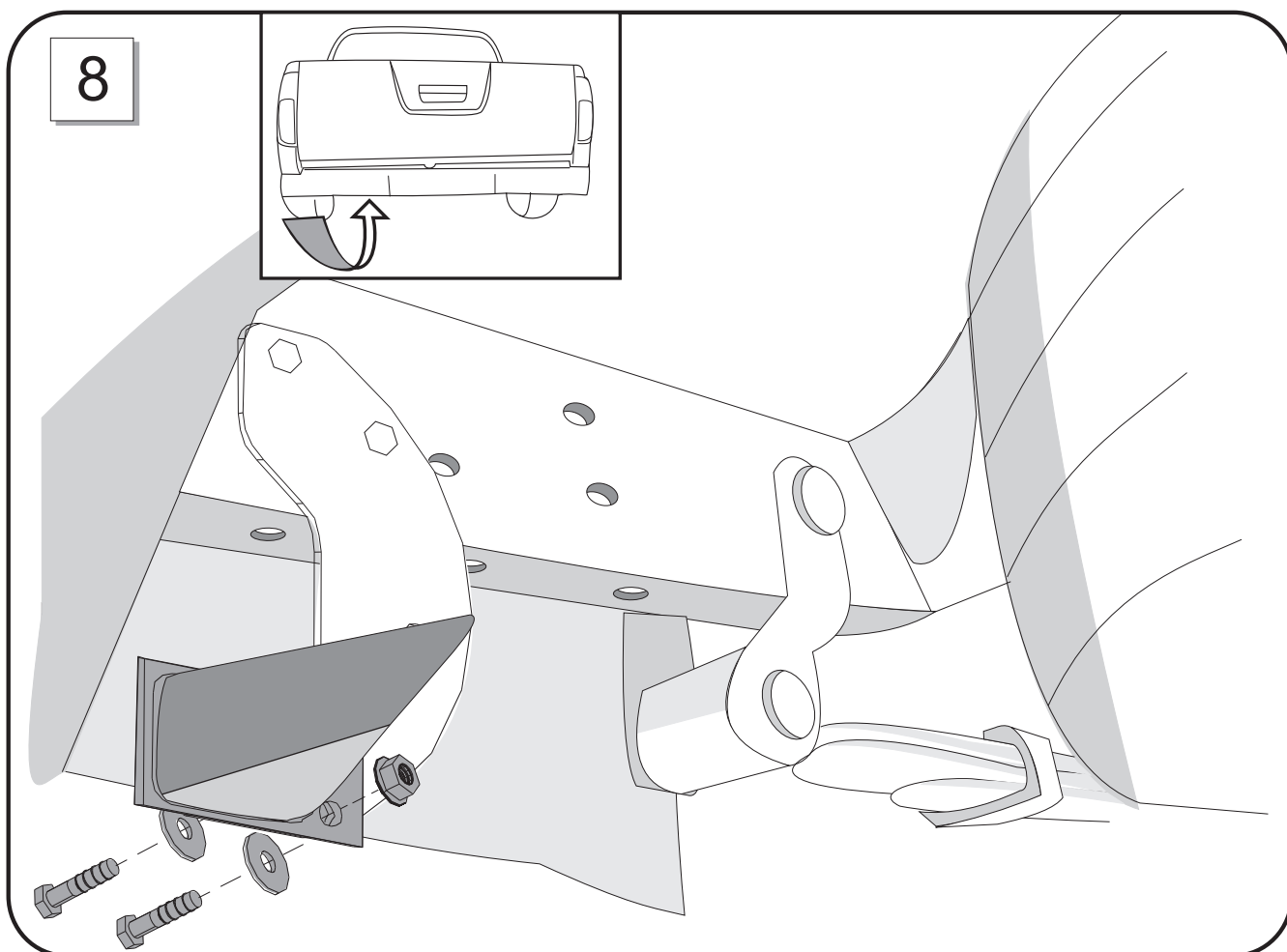
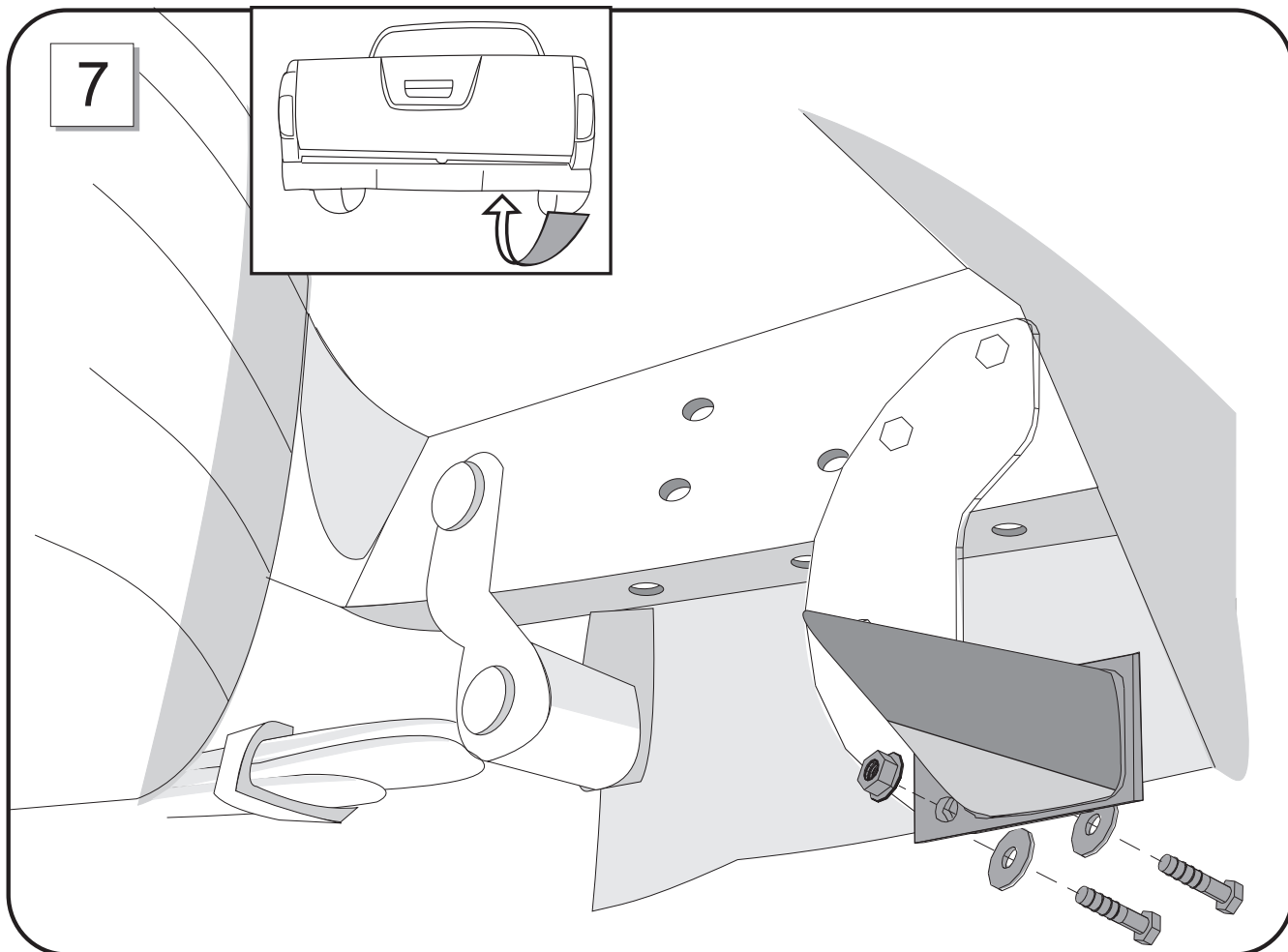

9

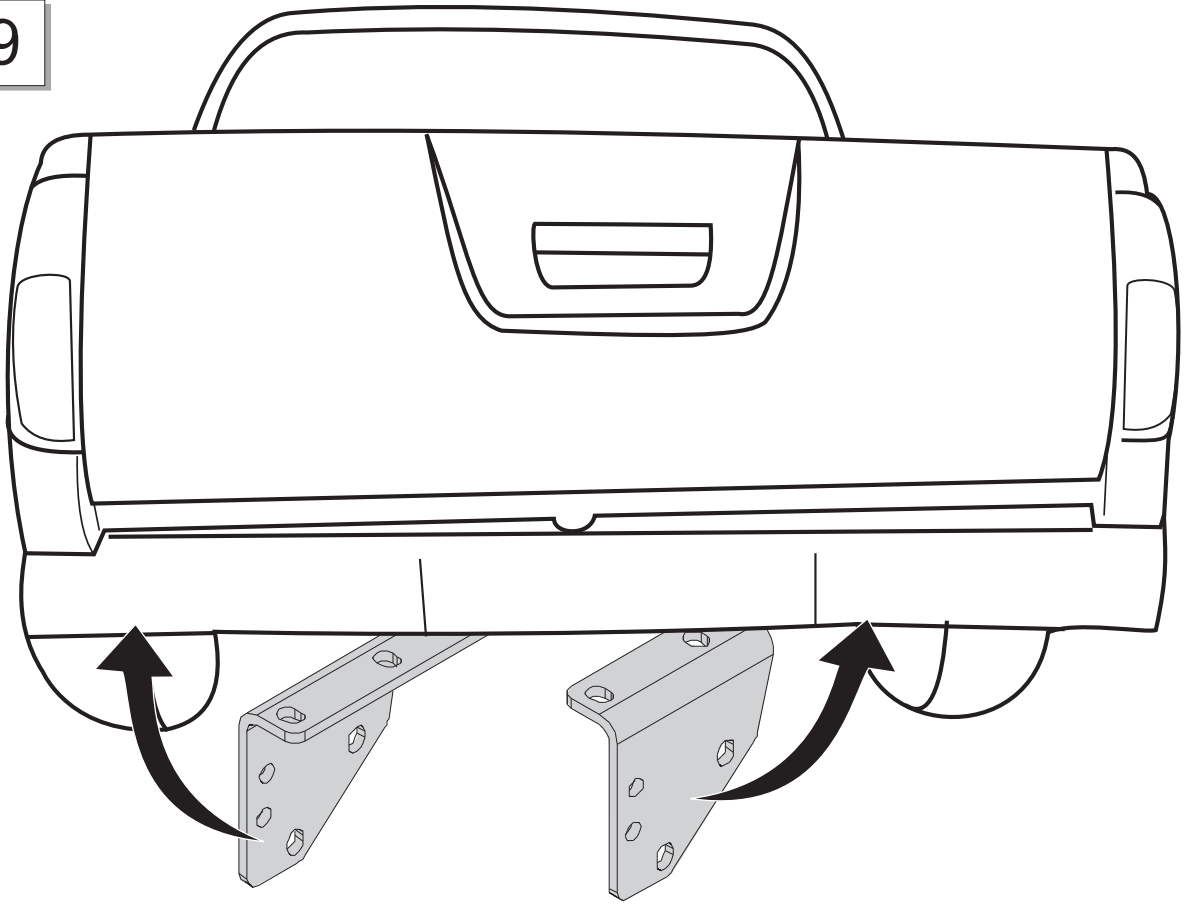

10

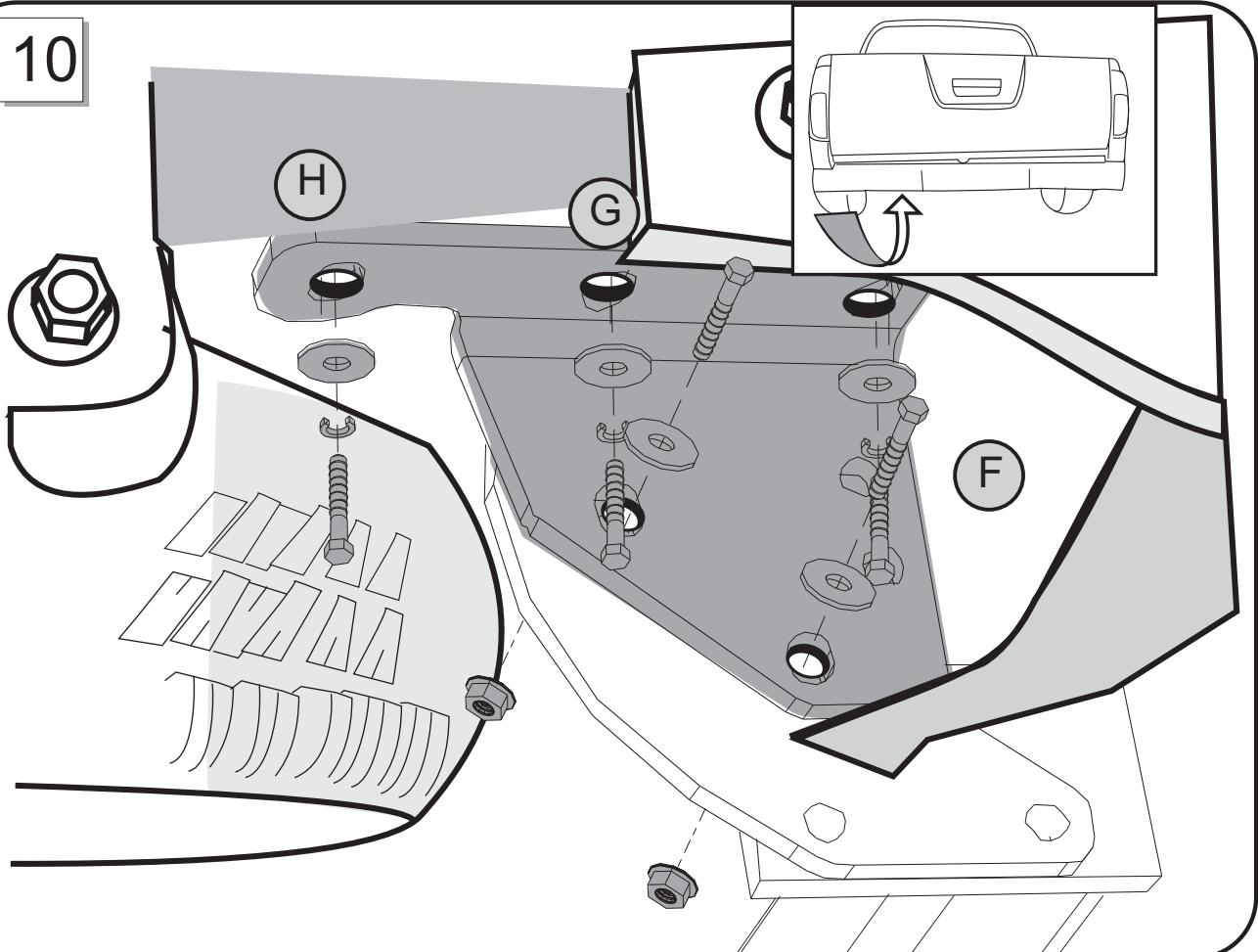

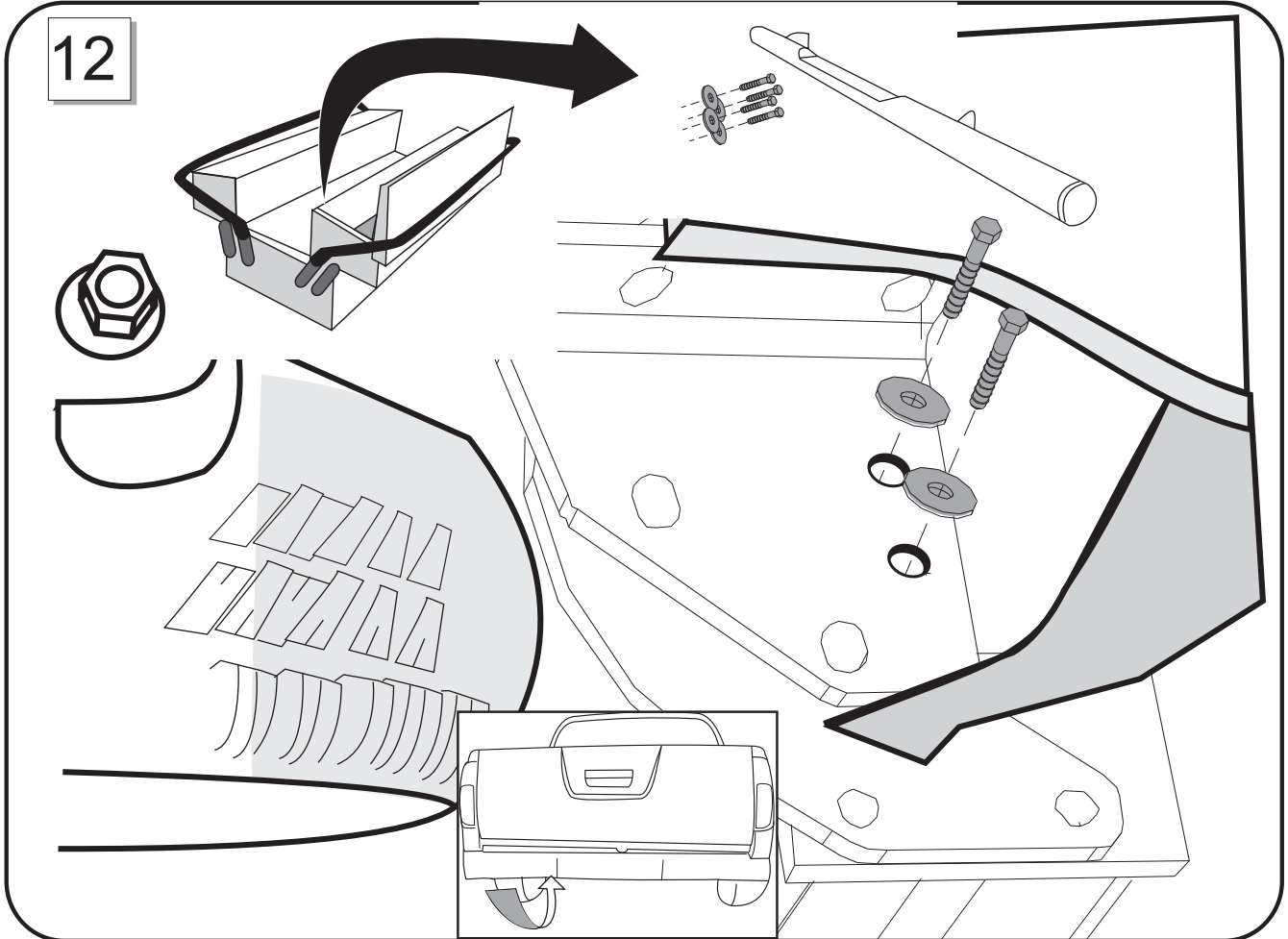
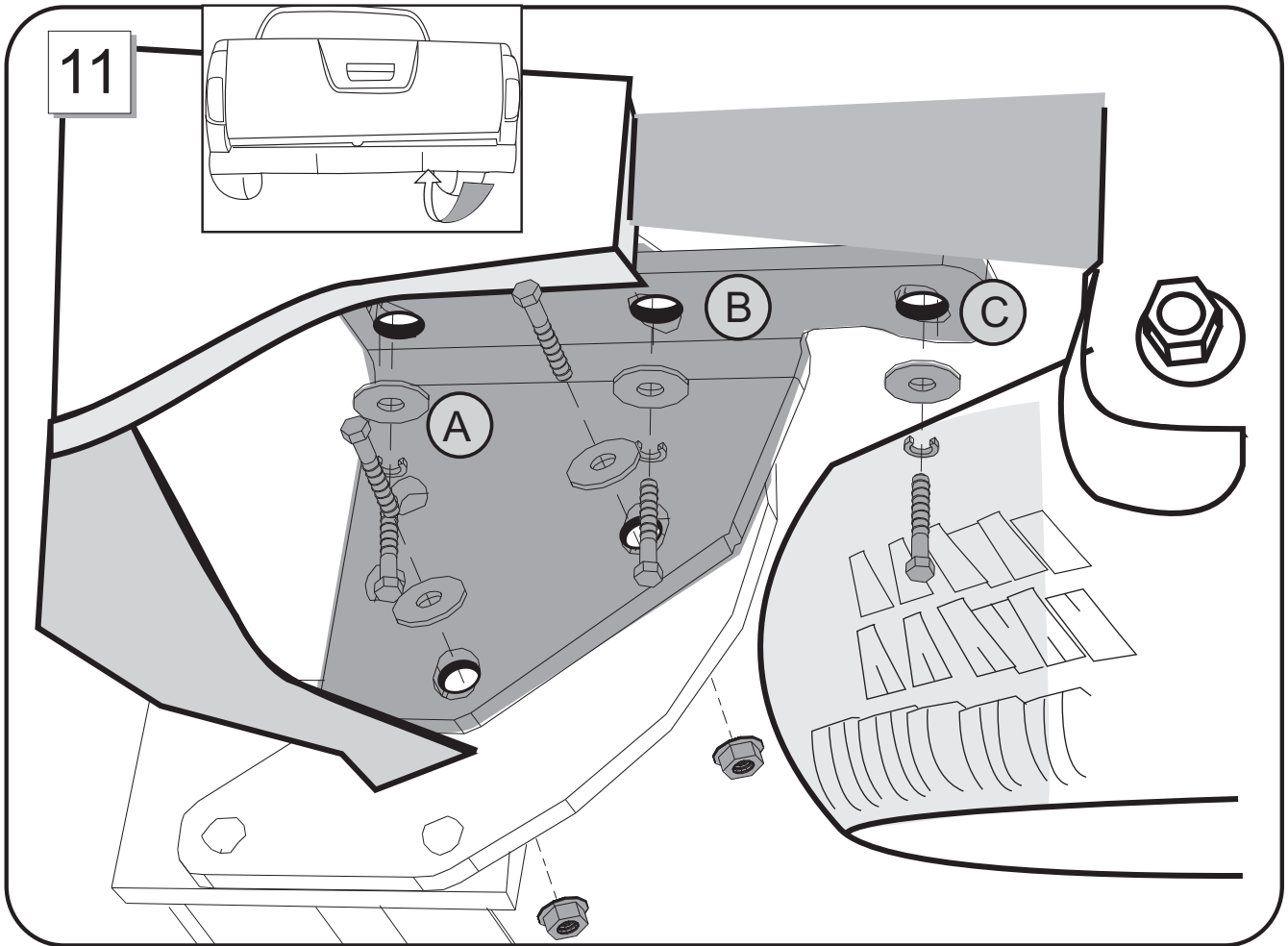

13

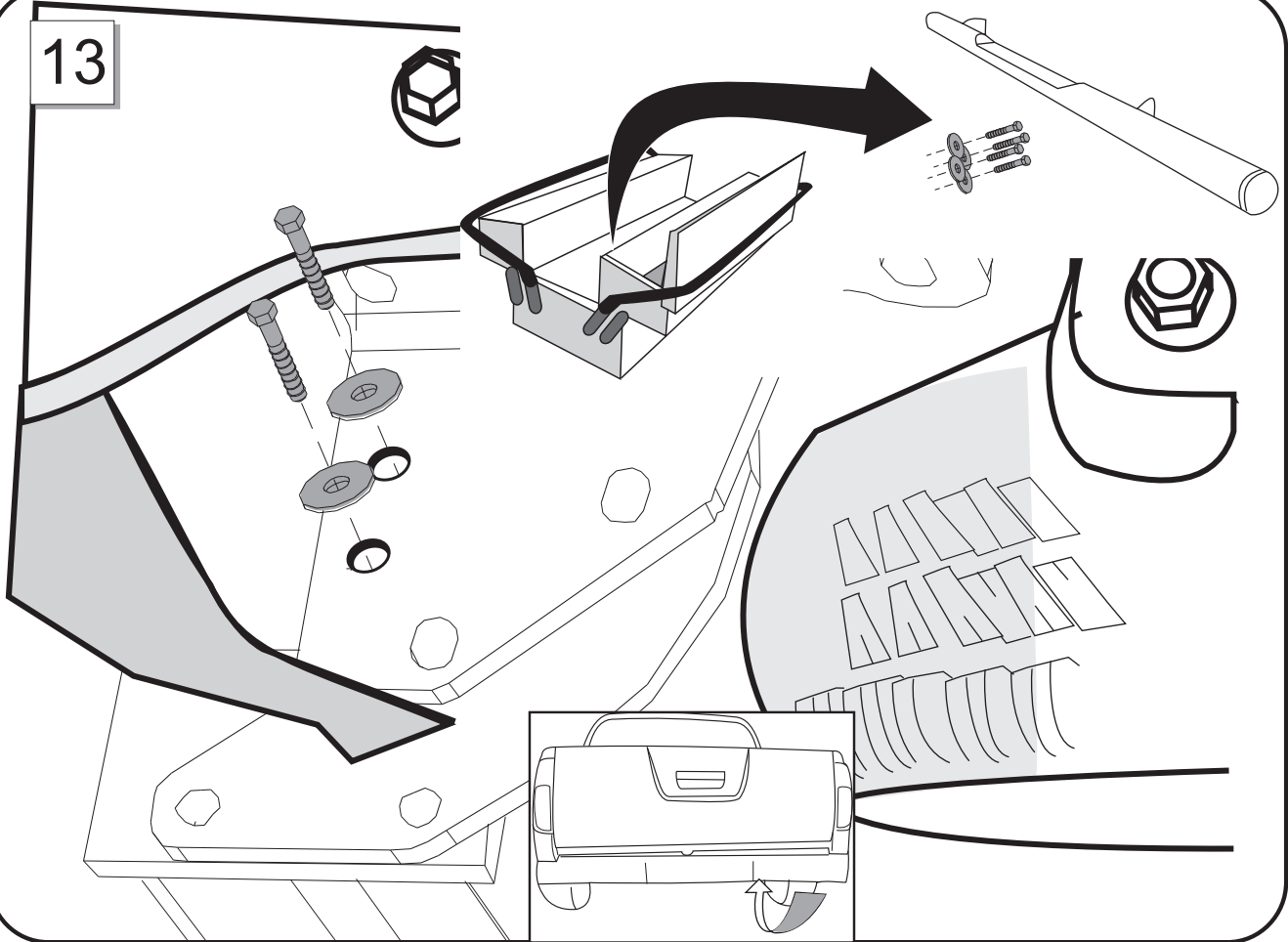

14

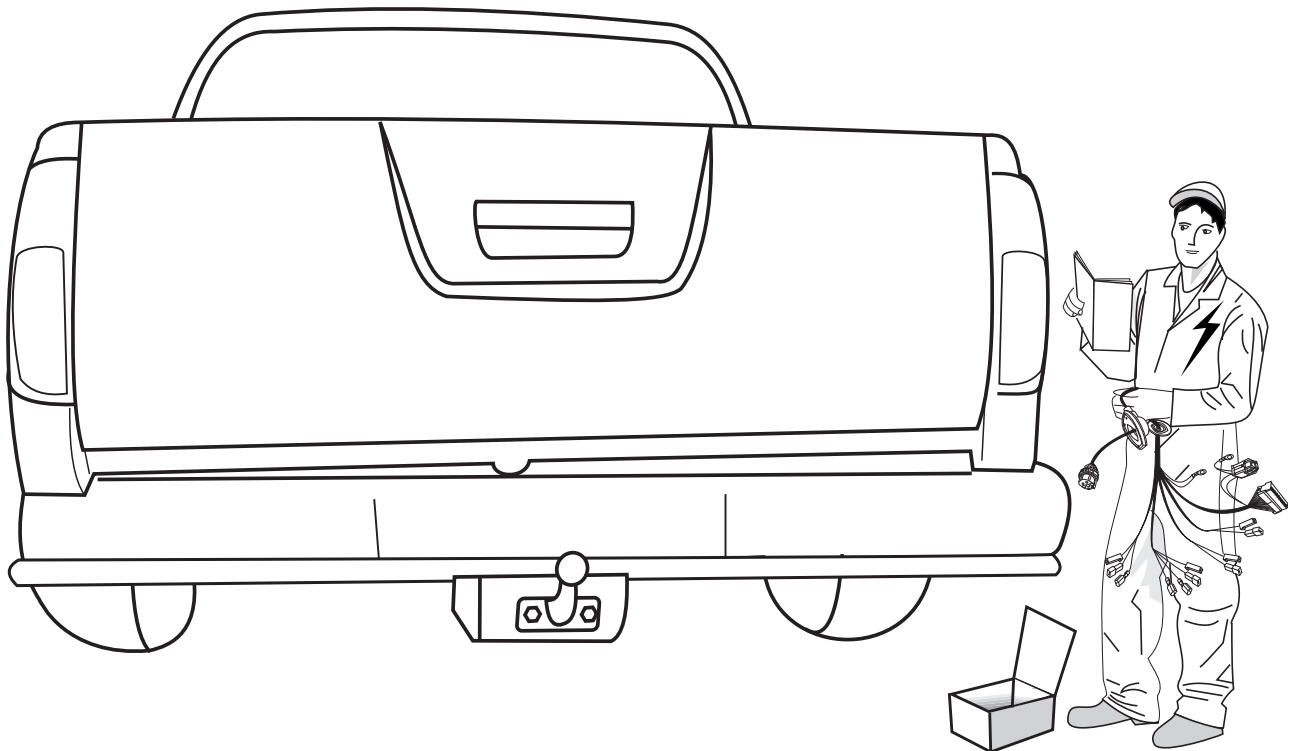

15

URBENi
150 kg

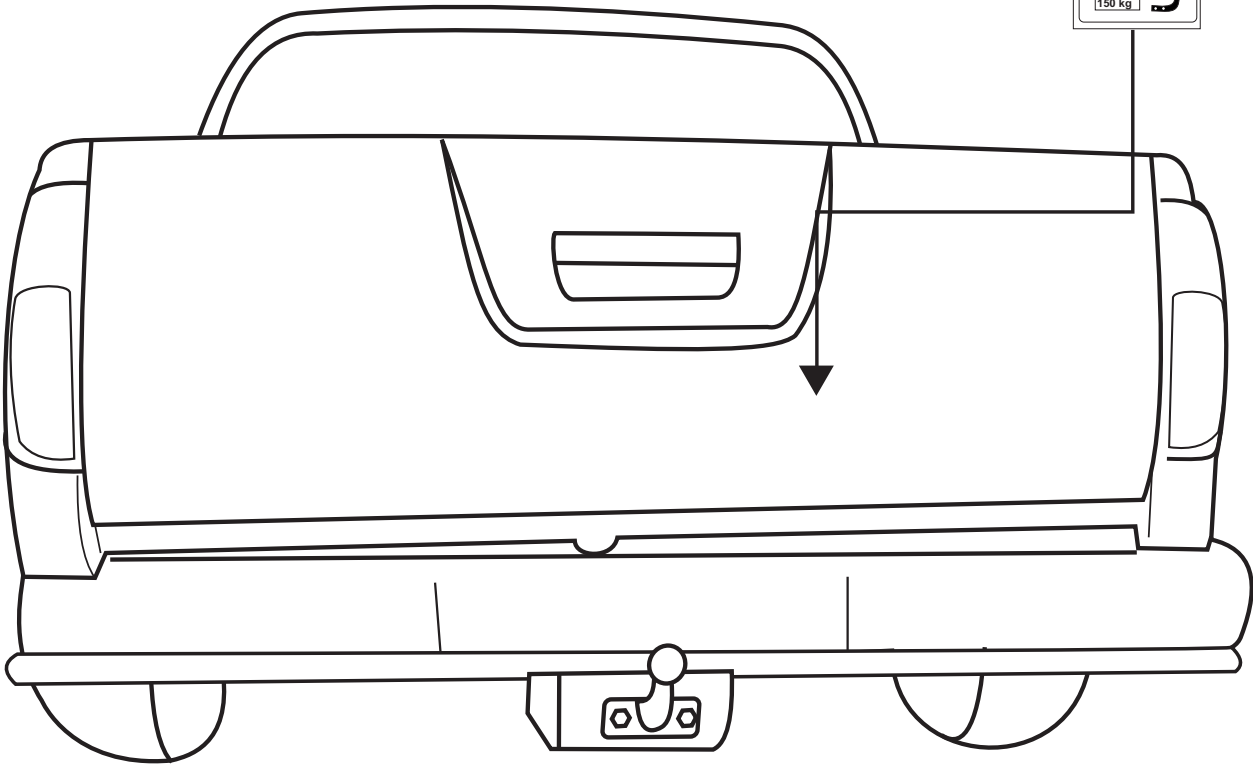

16

E I

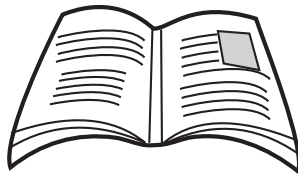

NL GR IRL DK
GB F D CZ

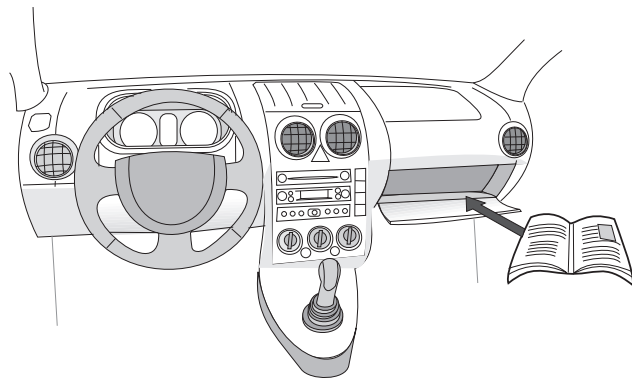
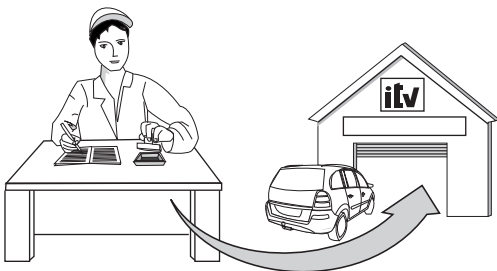

MINISTERE DES TRANSPORTS

Luxemburg, le 28 juin 2006
19-21, Boulevard Royal
L-2910 LUXEMBOURG
Tél- 478-1 Télécopieur 241817 - Télex 1465 CIVAIR LU

REFERENCE : e13*94/20*94/20*2262*00

ANNEXES : Documentation technique



Certificat de réception CE par type
EC Type-Approval Certificate

Communication concernant¹
Communication concerning¹

- la réception
the type approval
- ~~l'extension de la réception~~
~~the extension of type approval~~
- ~~le refus de la réception~~
~~the refusal of type approval~~
- ~~le retrait de la réception~~
~~the withdrawal of type approval~~

d'un type d'élément de construction visé par la directive 94/20/CE
of a type of a component with regard to Directive 94/20/EC

Numéro de réception² : e13*94/20*94/20*2262*00
Type-approval number² :

Motif de l'extension : Not applicable
Reason of extension :

SECTION I
SECTION I

- 0.1. **Marque (raison sociale du constructeur) :** URBENI
Make (trade name of manufacturer) :
- 0.2. **Type :** N 019
Type :
- Description(s) commerciale(s) générale(s) :** Not applicable
General commercial description(s) :
- Version(s)/Variante(s) :** Not applicable
Version(s)/Variant(s) :
- 0.3. **Moyens d'identification du type, tels que marqués sur l'élément de construction :** See point 0.7.
Means of identification of type if marked on the component :
- 0.3.1. **Emplacement de ce marquage :** See point 0.7.
Location of that marking :

CERTIFICADO DE MONTAJE

D., expresamente autorizado por la empresa....., domiciliada en provincia de, calle n° teléfono, dedicada a la actividad, con n° de Registro Industrial y n° de registro especial (1).....

CERTIFICA

Que la mencionada empresa ha realizado la/s reforma/s, y asume la responsabilidad de la ejecución, sobre el vehículo marca tipo variante denominación comercial matrícula y n° de bastidor de acuerdo con:

La normativa vigente en materia de reformas de vehículos.
Las normas del fabricante del vehículo aplicables a la/s reforma/s llevadas a cabo en dicho vehículo.
El proyecto técnico de la/s reforma/s, adjunto al expediente.

OBSERVACIONES:

INSTALACIÓN DE DISPOSITIVO PARA REMOLCAR,

MARCA:

Nº HOMOLOGACIÓN: e.....*94/20*.....

VALOR D:kN

VALOR S:Kg

M.M.R.:Kg

..... a de de 20.....

Firma y Sello

Fdo.:

(1) En el caso de que la reforma sea efectuada por un fabricante se indicará N/A



URBENI, S.L.

Pol. Centrovía, A-2, Km 303. c/Buenos Aires, nº10
50196 LA MUELA-ZARAGOZA (ESPAÑA)
Tel.: +34 976 14 44 01 / +34 902 41 78 50
Fax.: +34 976 14 44 02

DA COMPILARE PER IL COLLAUDO

DICHIARAZIONE DI CORETTO MONTAGGIO

La sottoscritta Ditta dichiara di aver montato in maniera corretta ed in conformità alle prescrizioni sia del costruttore del veicolo che del costruttore del dispositivo stesso il seguente dispositivo di attacco meccanico:

Tipo:

Il dispositivo di attacco meccanico sopra descritto è stato installato su autoveicolo tipo:

.....

targa:

.....

Si dichiara inoltre di aver informato l'utente del veicolo sull'USO e MANUTENZIONE del dispositivo stesso.

.....

TIMBRO E FIRMA

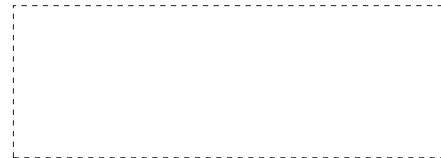

Dispositivo di traino

codice:

Per autoveicoli:

Tipo:

Clase e tipo di attacco:

Omologazione:

Valor D:

Massa Massima

Rimorchiabile:

Carico Verticale Massimo:

Larghezza max.

Rimorquiabile

per Caravan e T.A.T.S.: Vedere CARTA di
CIRCOLAZIONE VEICOLO

(motrice) + 70 cm =.....

arrotondare ai 5 cm superiore

(vedi D.M. 28/05/85)

