

Kit de montage FORD RANGER

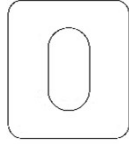

X12
O0031

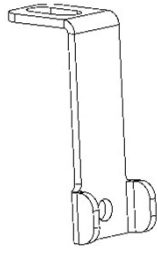

X2
O0010



X2
O0011

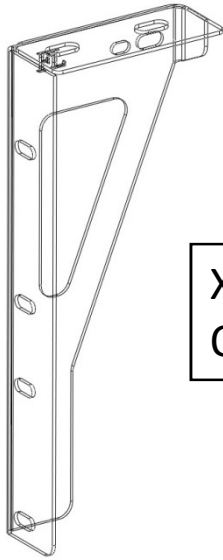

X1
O0014G

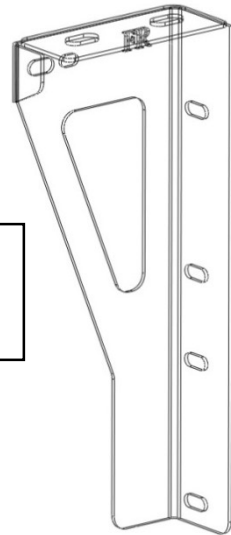

X1
O0014D

X1
O0013G

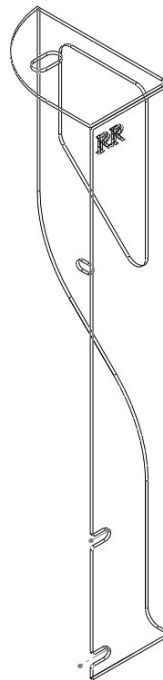
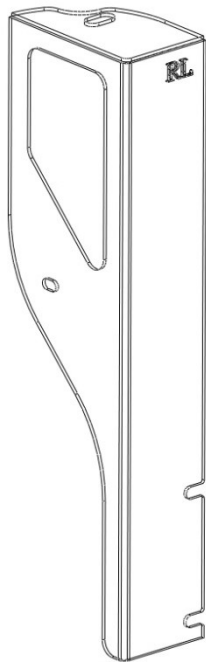

X1
O0013D

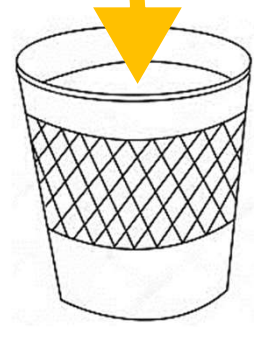
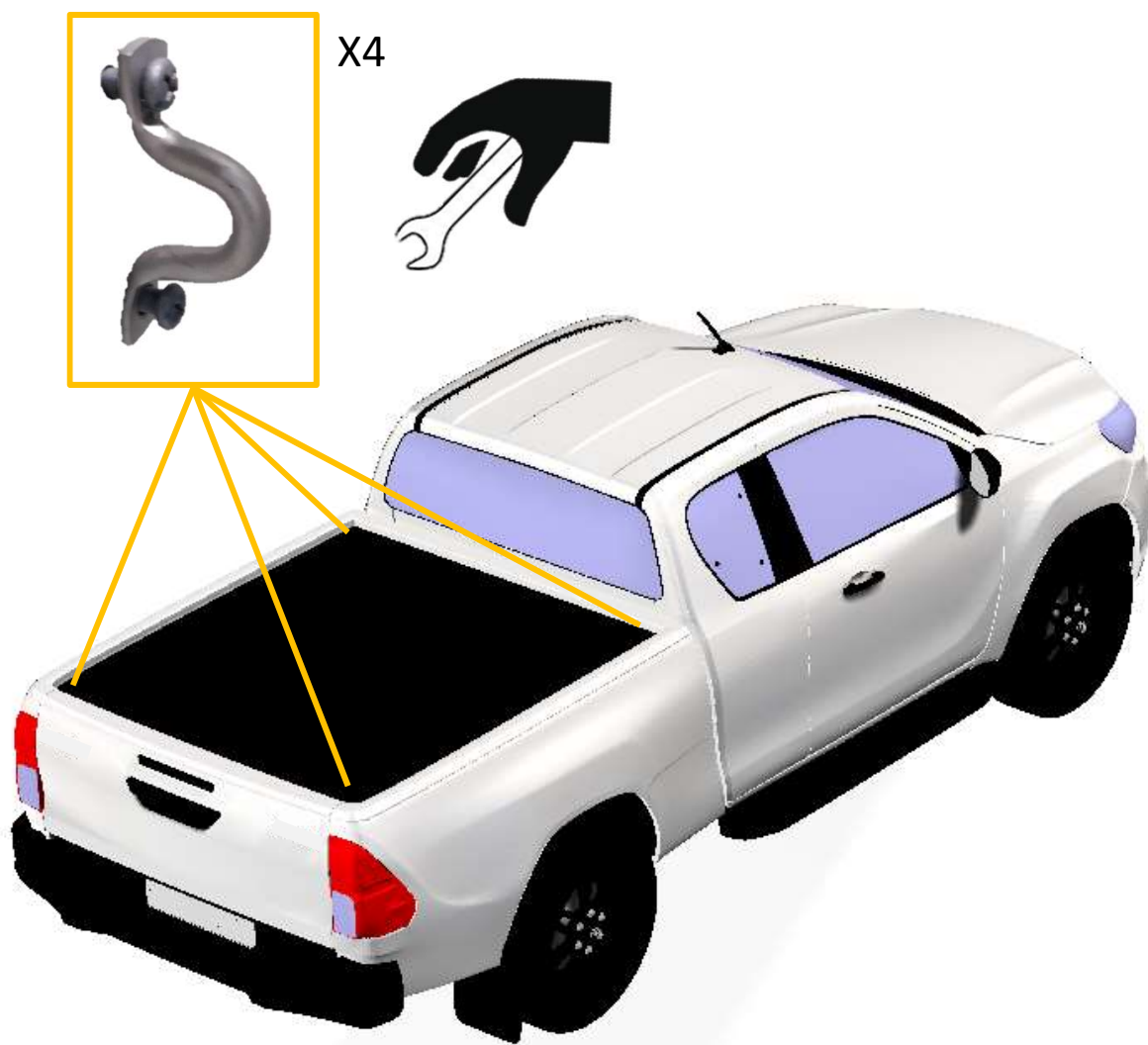

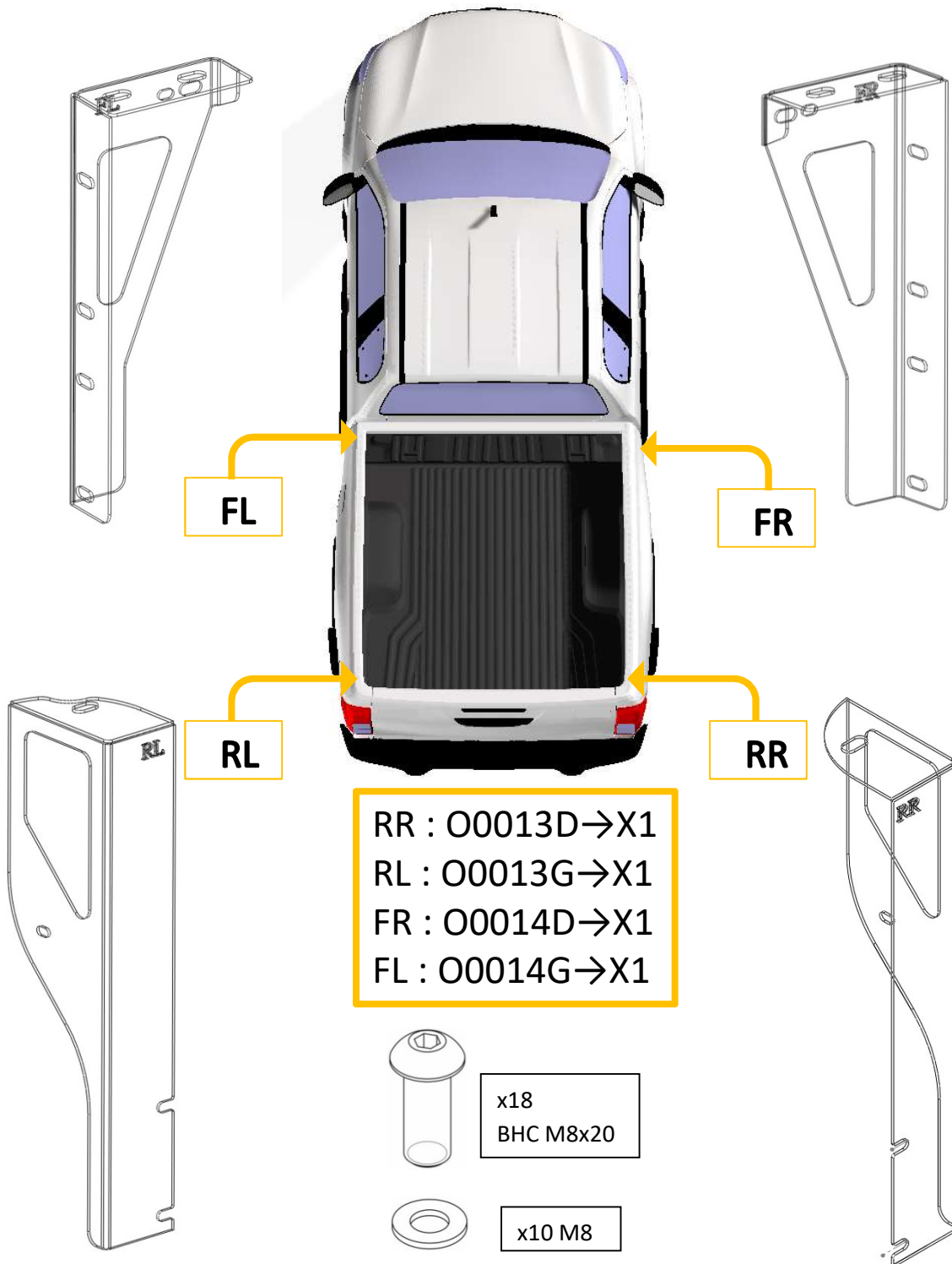



x18
BHC M8x20

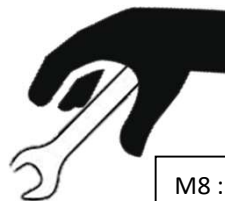
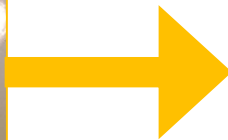

N°4
X4

M8 : $C_s = 16 \text{ Nm}$



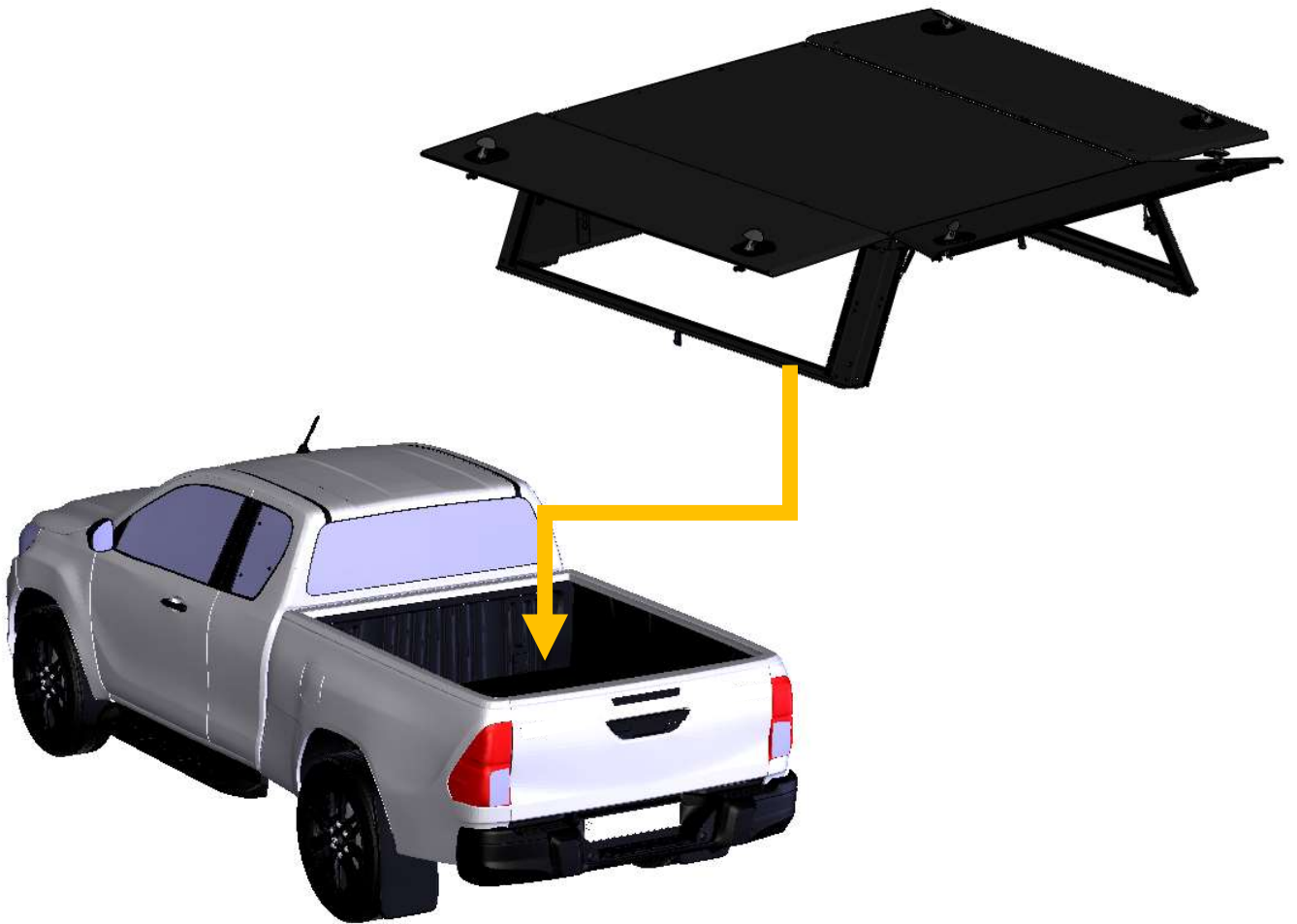

X6
O0031

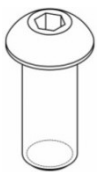

x6
BHC M10x25



x12 M10

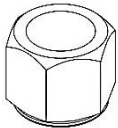

x6 M10



M10 : C_s = 20 Nm



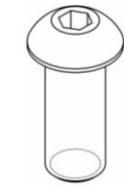

x2
BHC M6x16

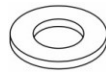

x2 M6

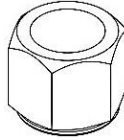

x2 M6



N°1
X2

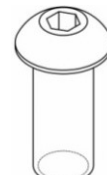

x2
BHC M8x25



x2 M8

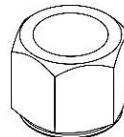

x2 M8



N°2
X2

M8 : $C_s = 6 \text{ Nm}$
M6 : $C_s = 6 \text{ Nm}$

HARD TOP

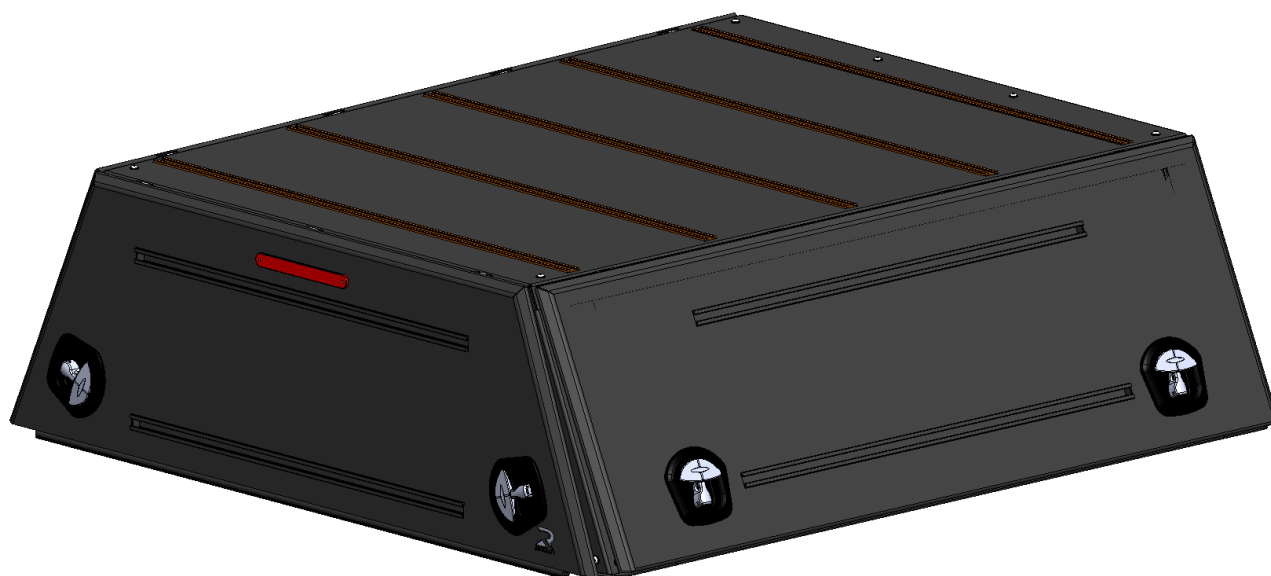

GUIDE DE MONTAGE



x22
BHC M4x16
A4701_5



X4
CHC M4x12
A4563_20



X47
BHC M8x20
A4861_10



x48 M4
A4633_3

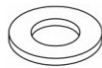

X59 M8
A4633



X47 M8
Plastic
A4634_9



x48 M4
A4701_5



X60 M8
A4701_3

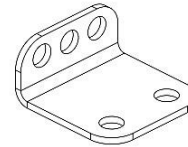

x2

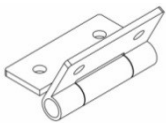

x11
A5913_7

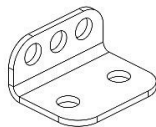

x4



x1,5 m
A7003_1

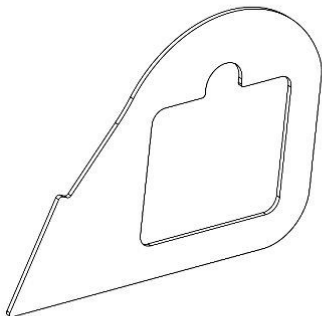

x1
O0012



x13 m
A7003_3

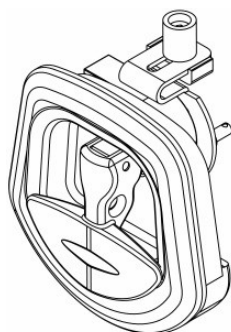

x6
A5911_9

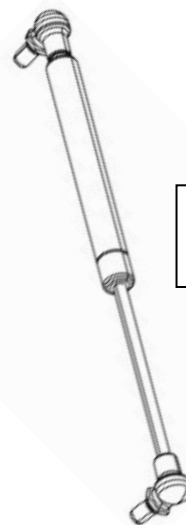

x6
O0021

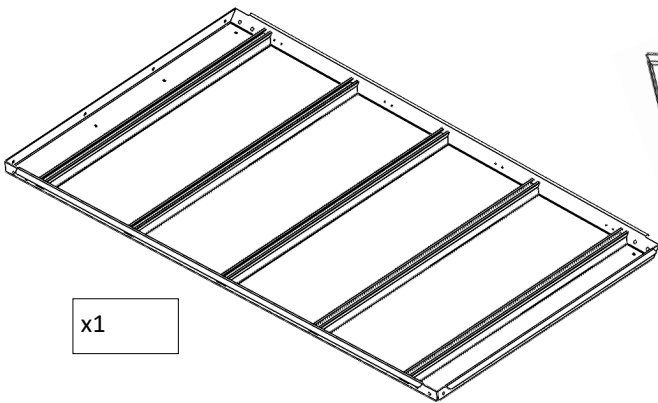

x1

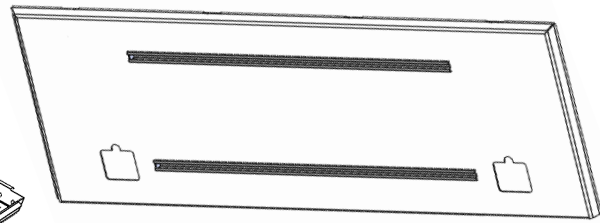

x2

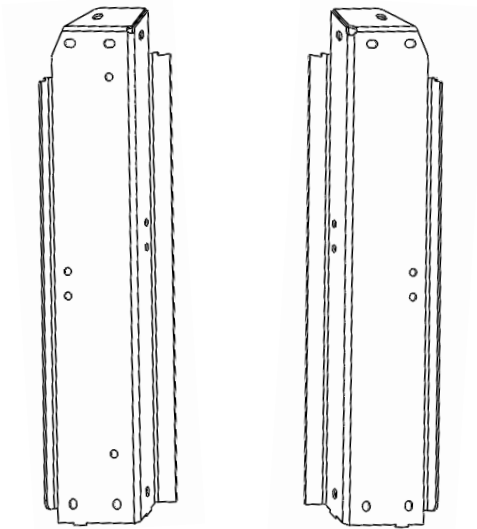

X1 LEFT

X1 RIGHT

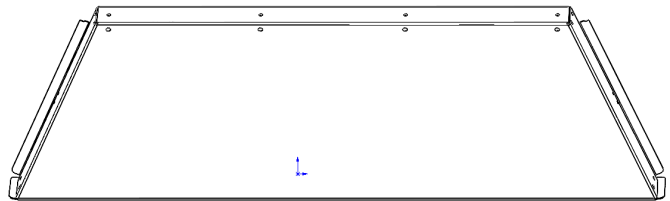

x1

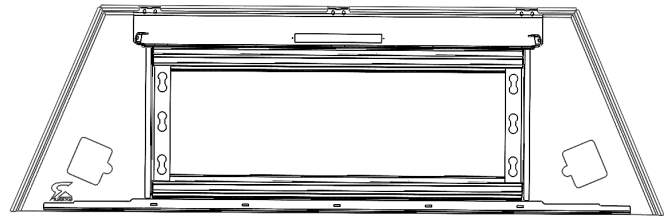

x1

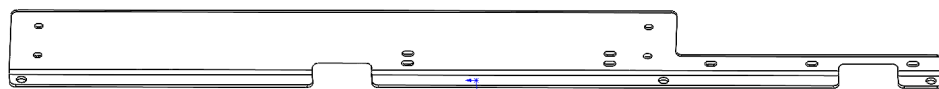

x1



x1

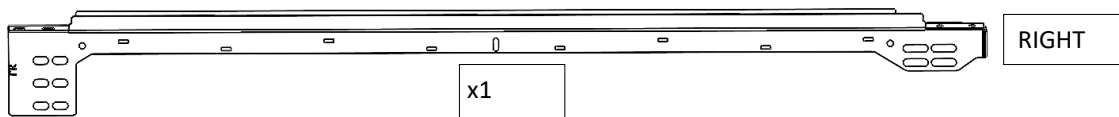

x1

RIGHT

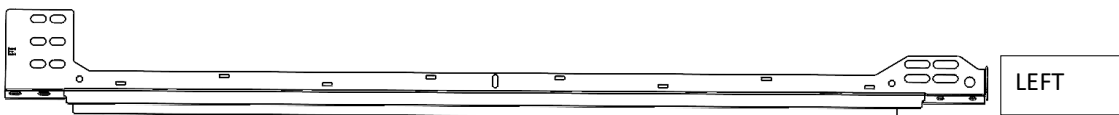

x1

LEFT

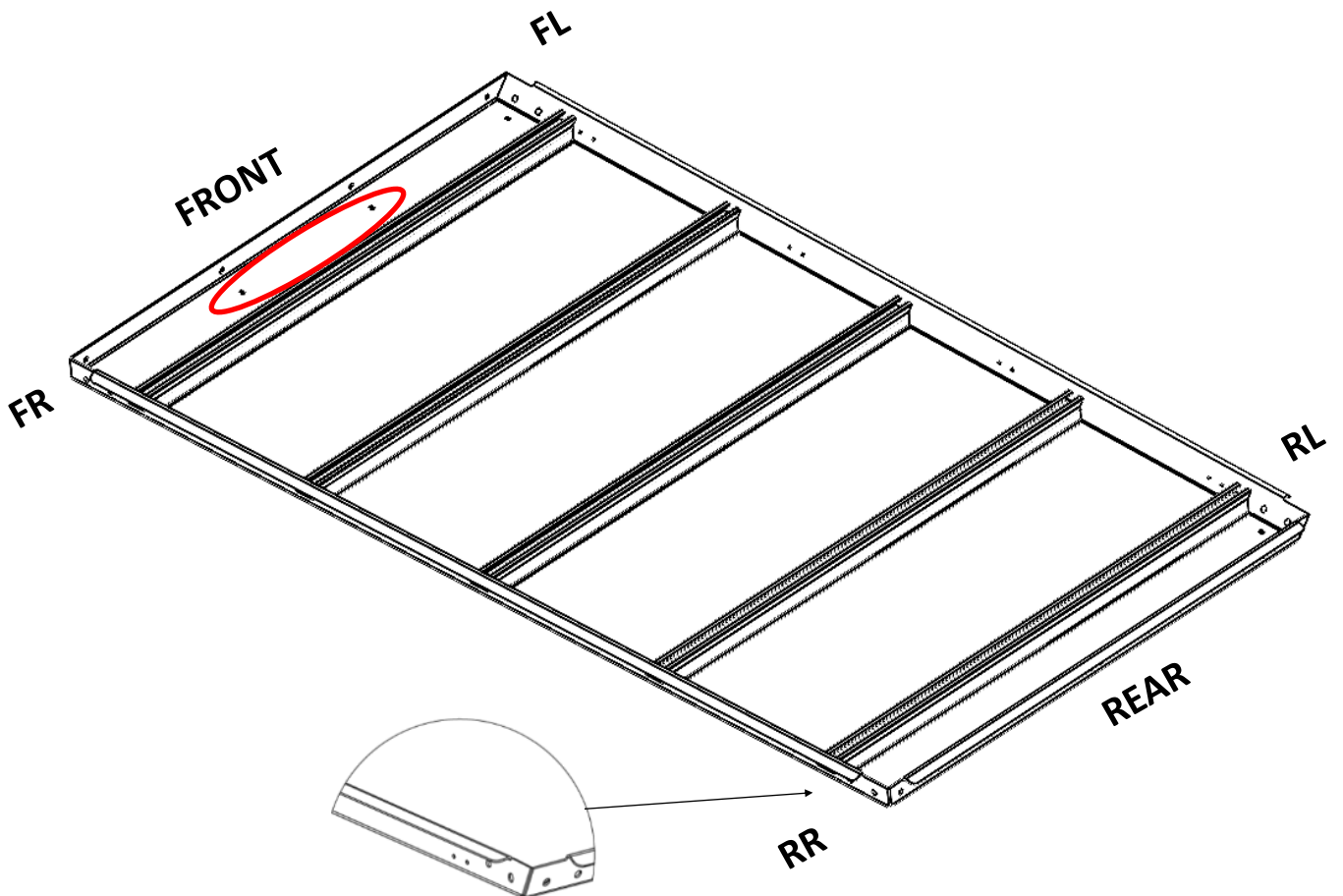
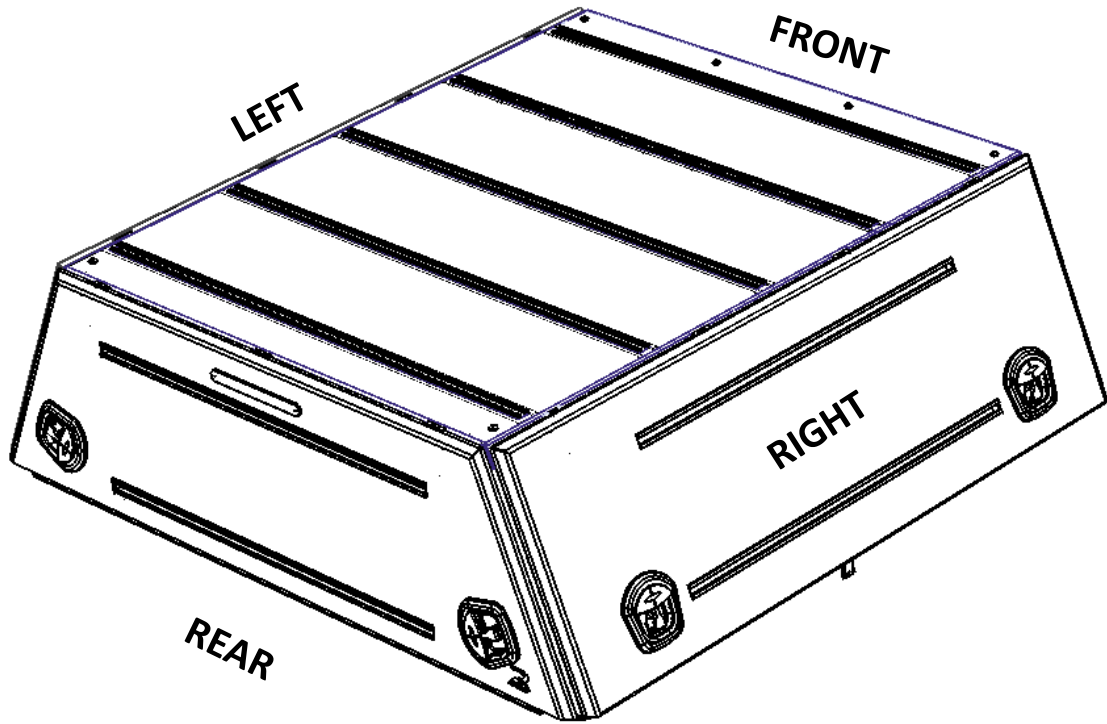

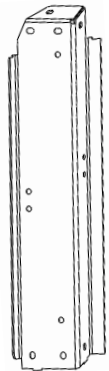

X1 LEFT

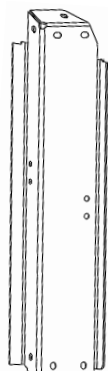

X1 RIGHT



X8 BHC M8x20

Outside



X8 M8 Plastic

Inside



X8 M8



X8 M8

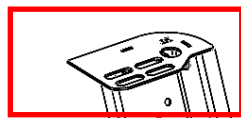
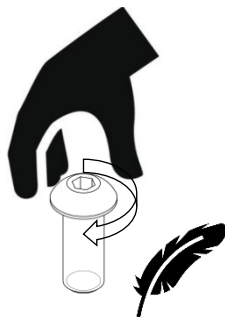

REAR LEFT



REAR RIGHT

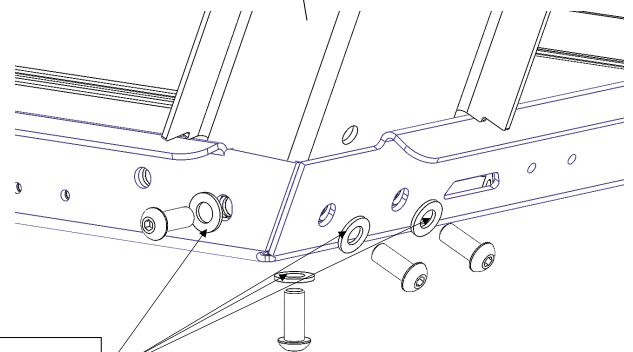
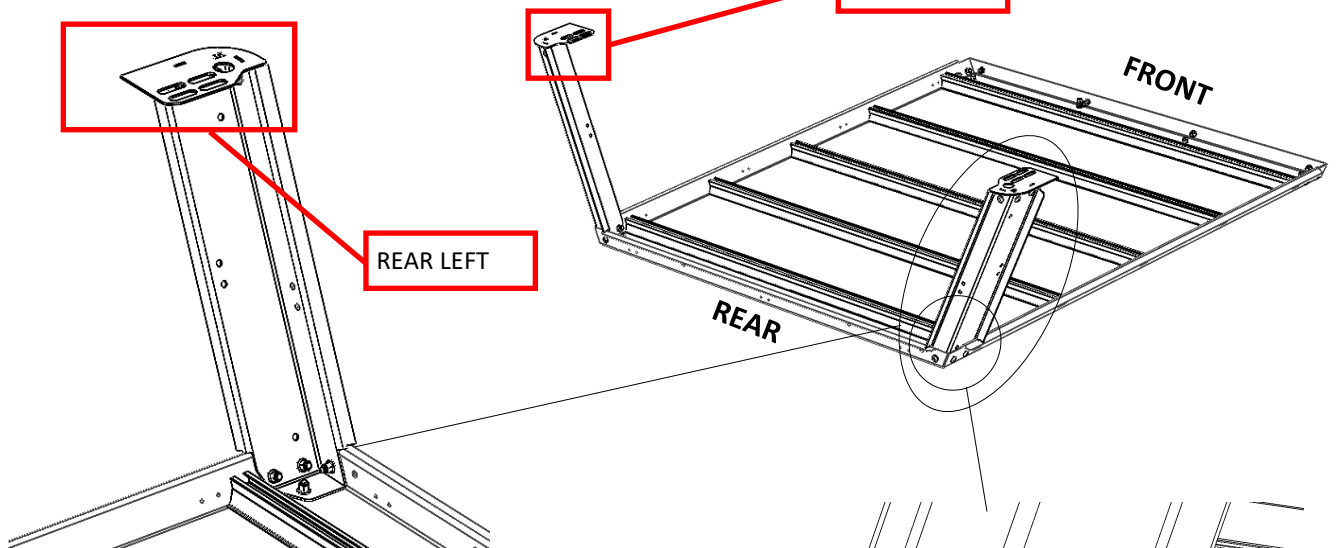

PLASTIC

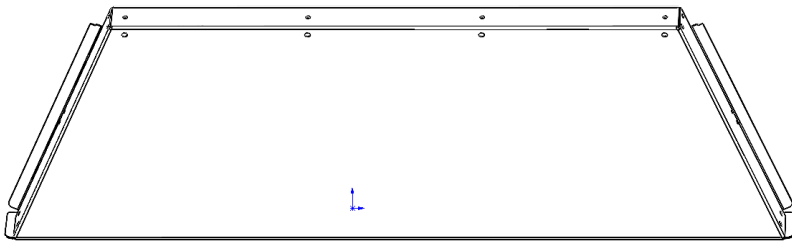

X1



X12 BHC M8x20

Outside



X12 M8 Plastic

Inside



X12 M8



X12 M8

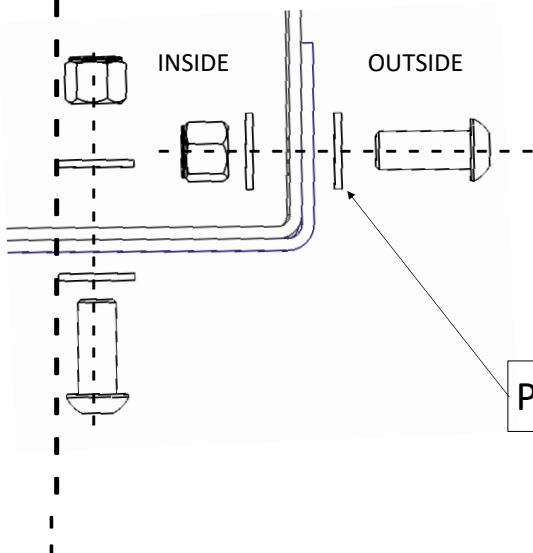
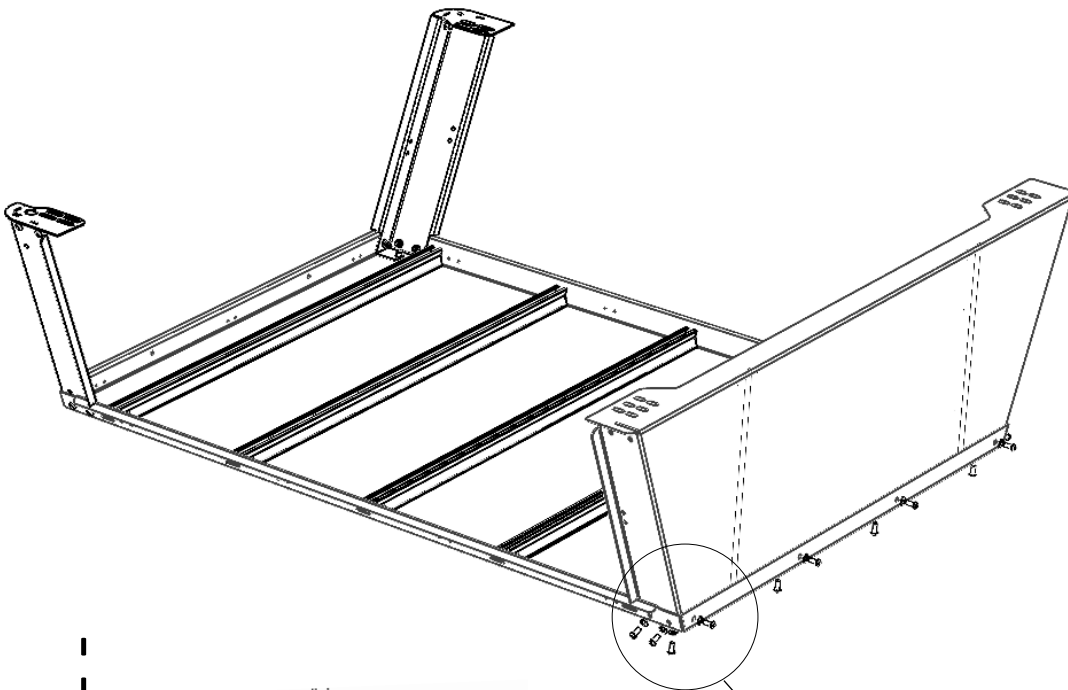
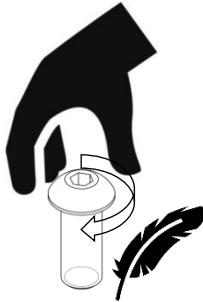

PLASTIC

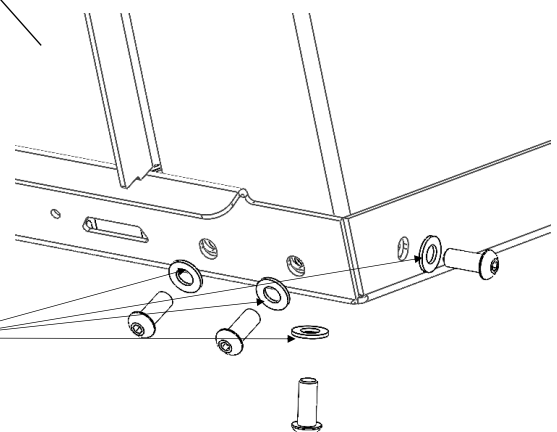

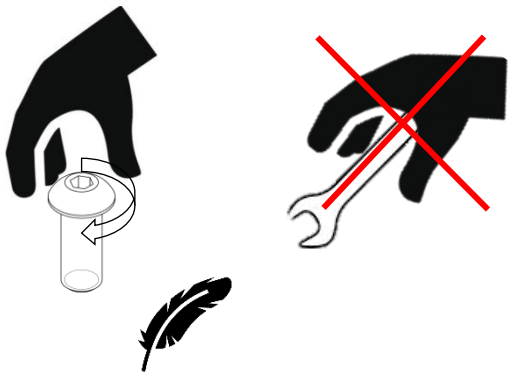

X10 BHC M8x20

Outside



X10 M8 Plastic

Inside



X10 M8



X10 M8

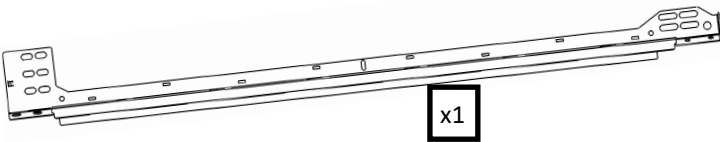
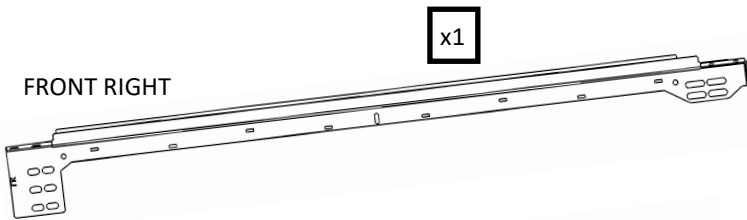

FRONT LEFT

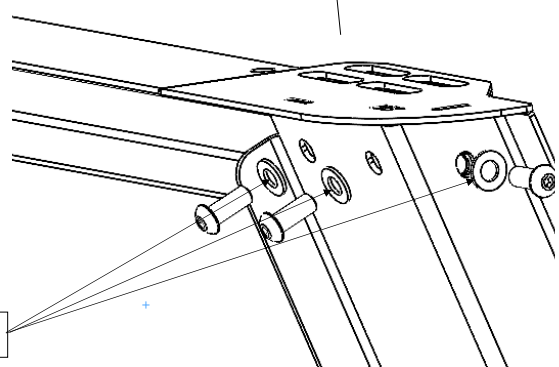
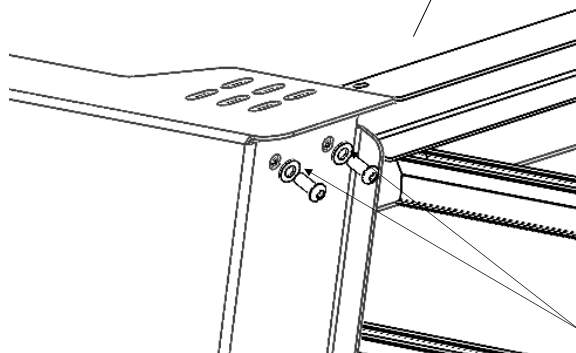
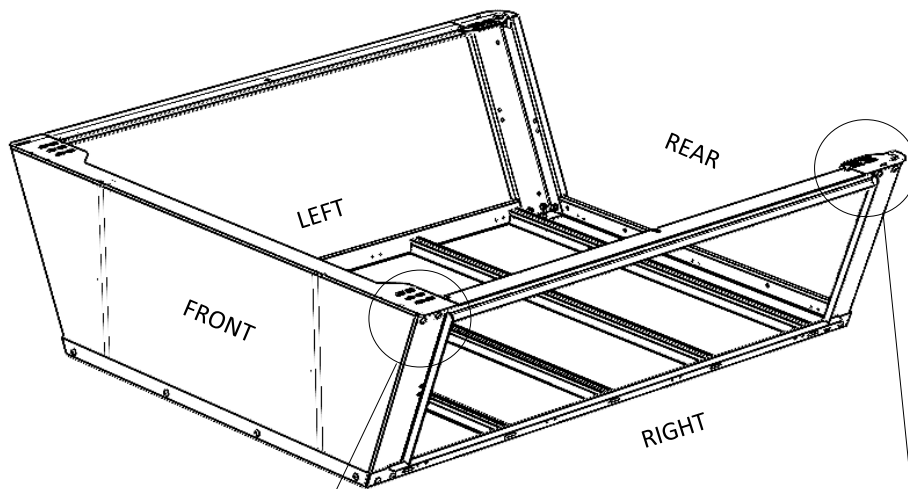

PLASTIC

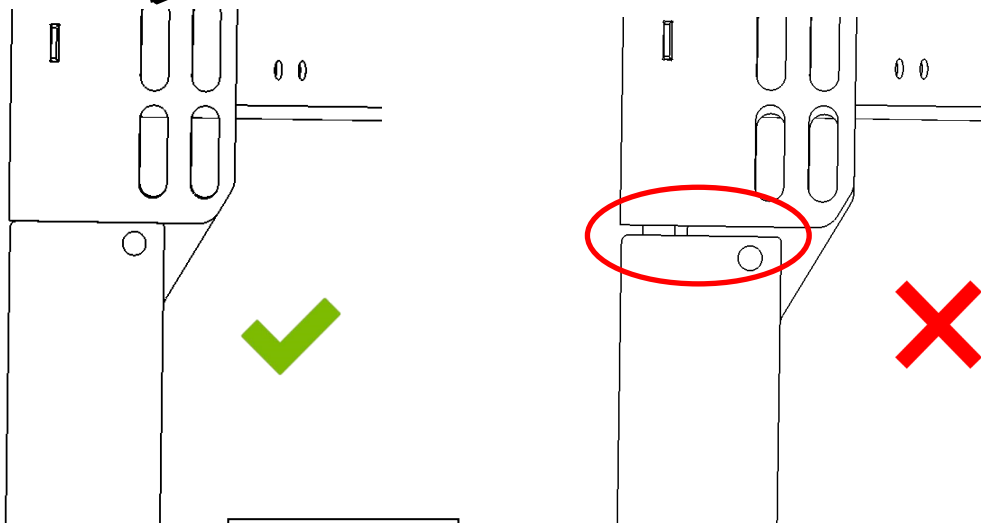
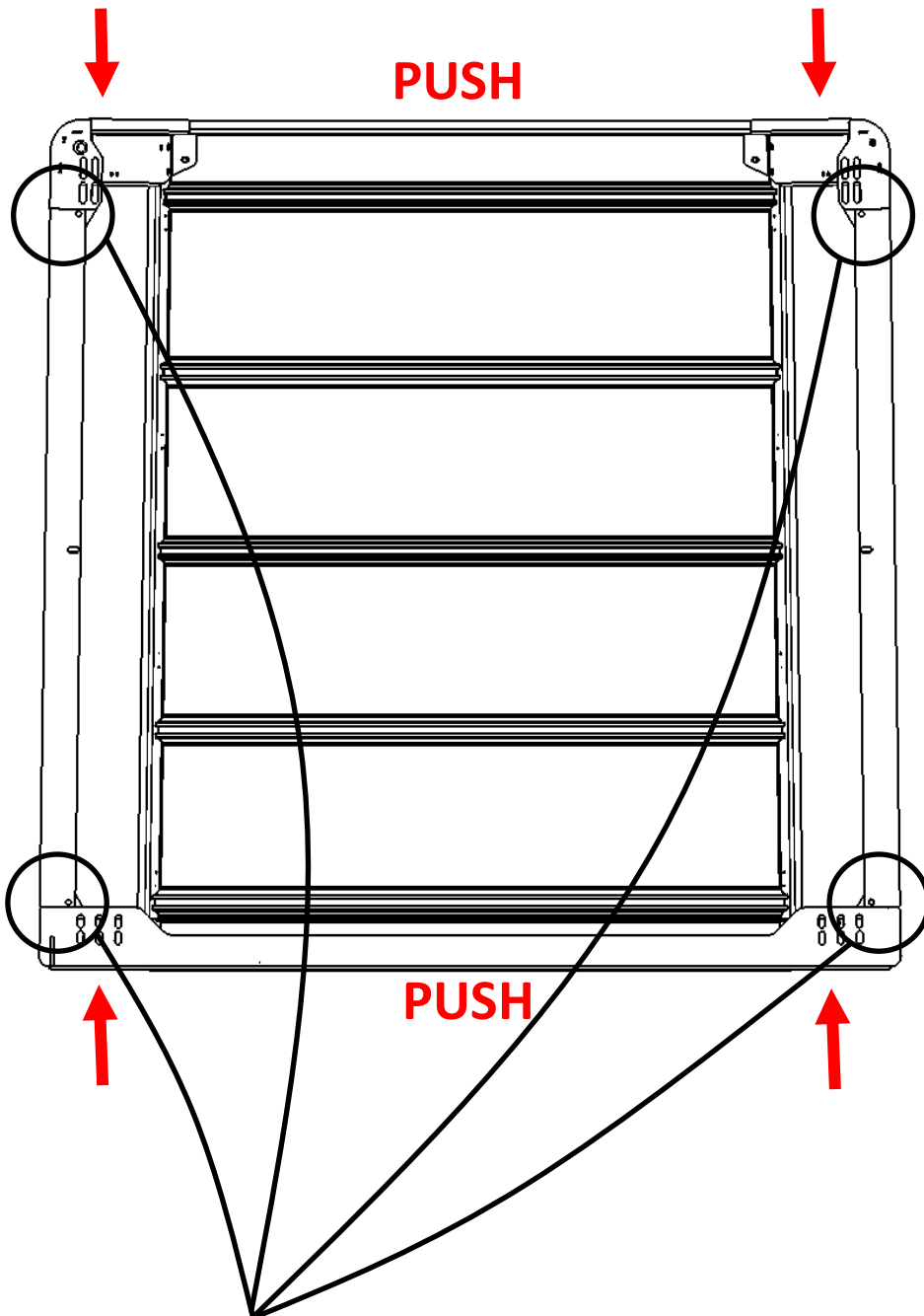

M8 : $C_s = 16 \text{ Nm}$
M6 : $C_s = 7 \text{ Nm}$

ALL SCREWS

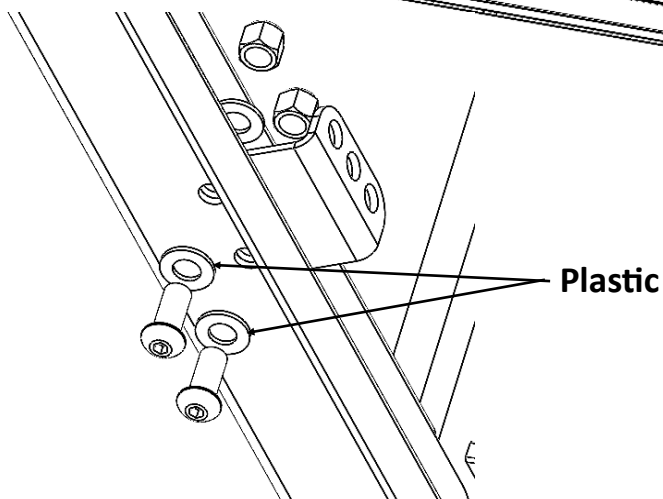
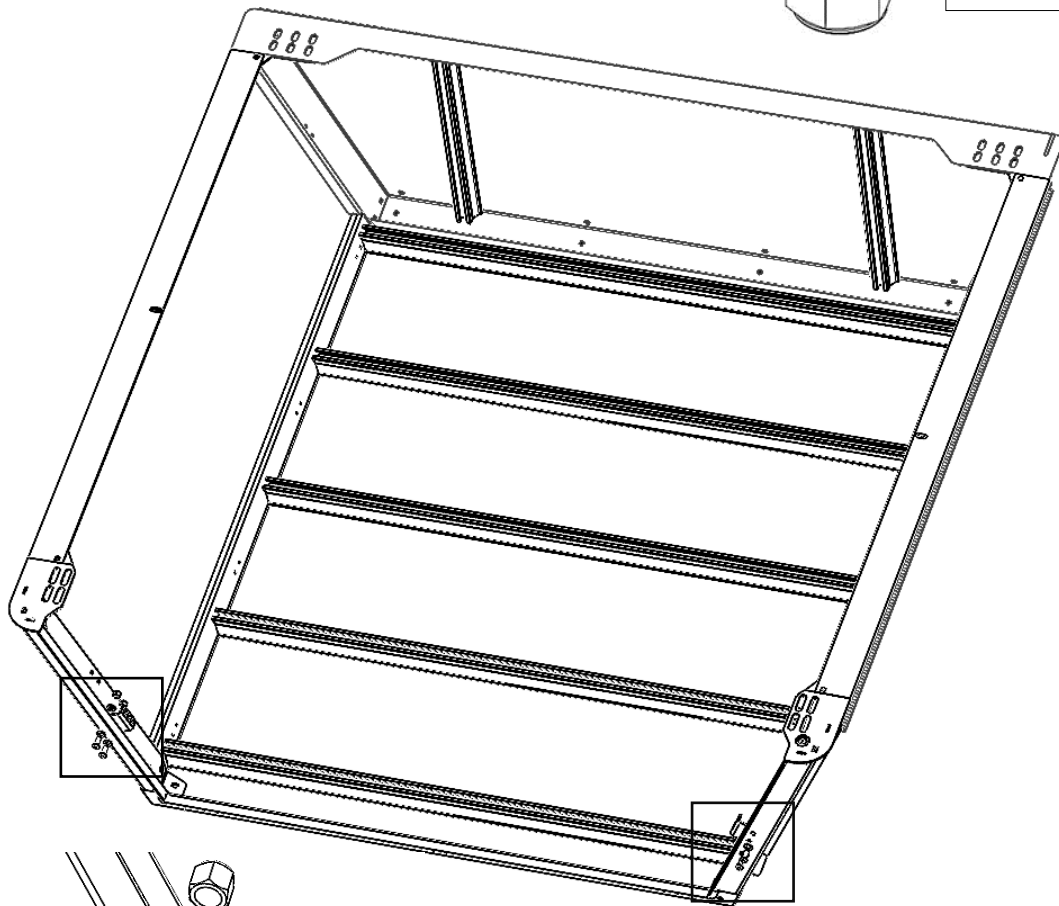
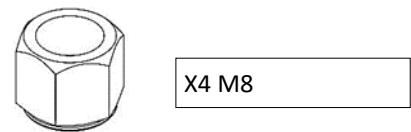
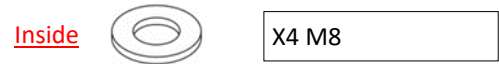
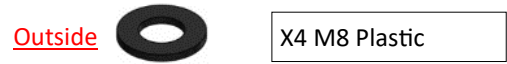
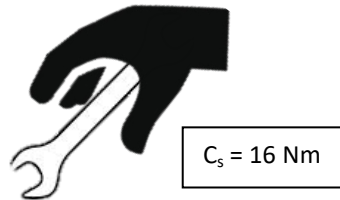
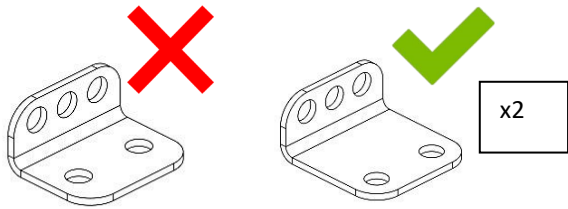

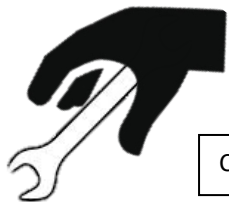
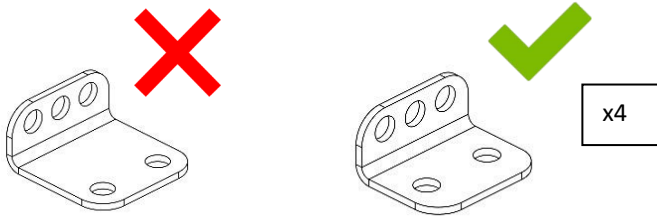

$C_s = 16 \text{ Nm}$



X8 BHC M8x20



Outside

X8 M8 Plastic



Inside

X8 M8



X8 M8

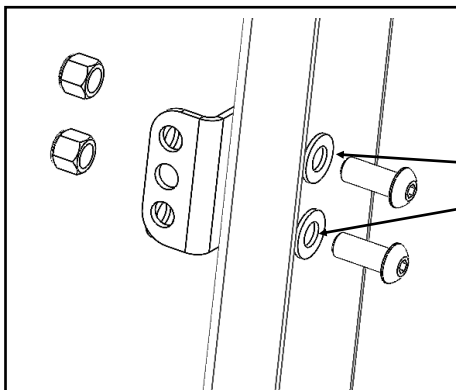

Plastic

x4

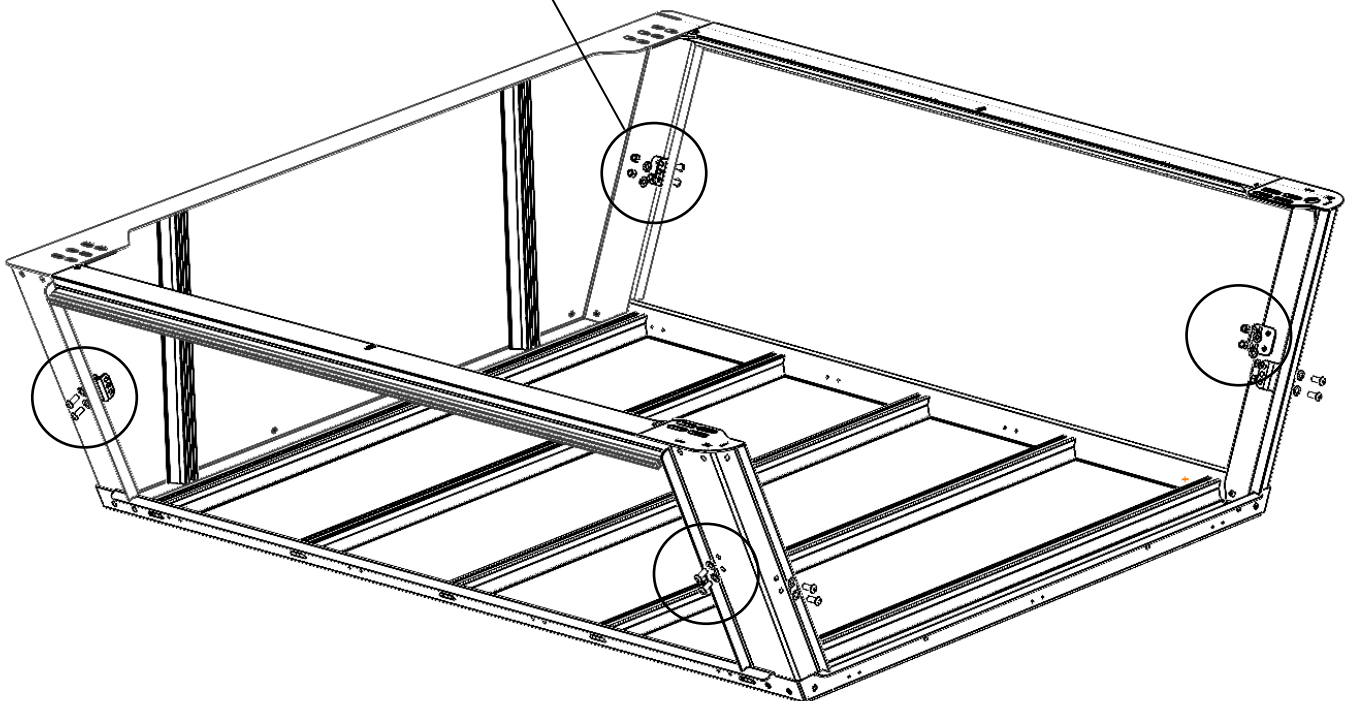

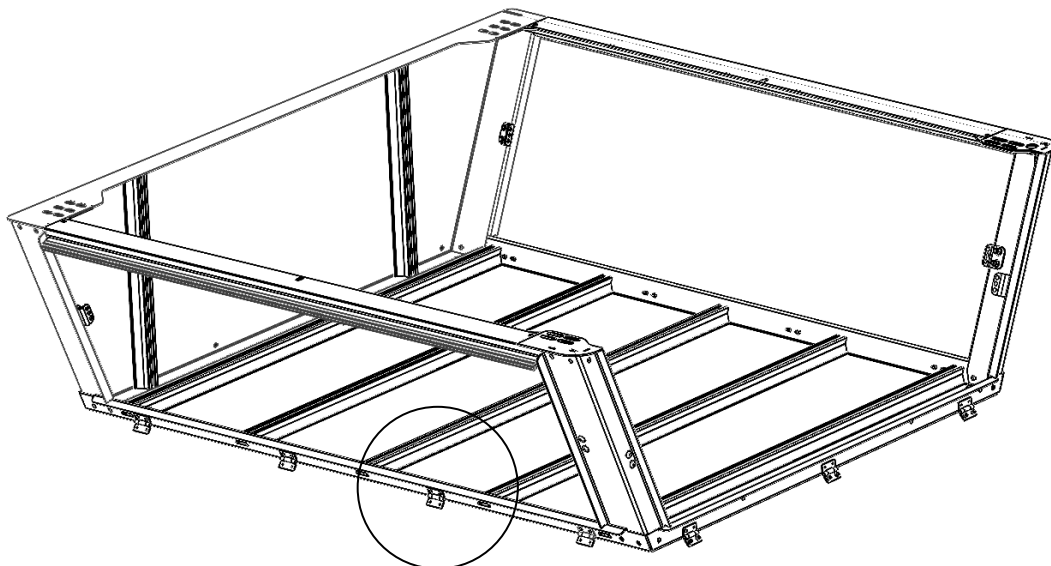
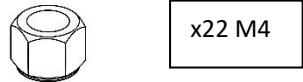
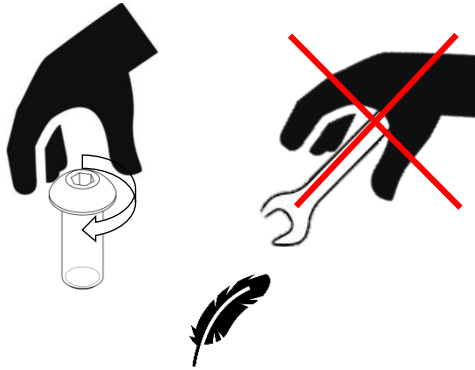
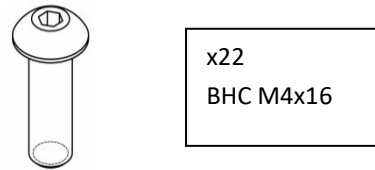
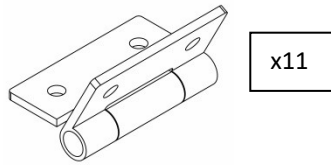

x11

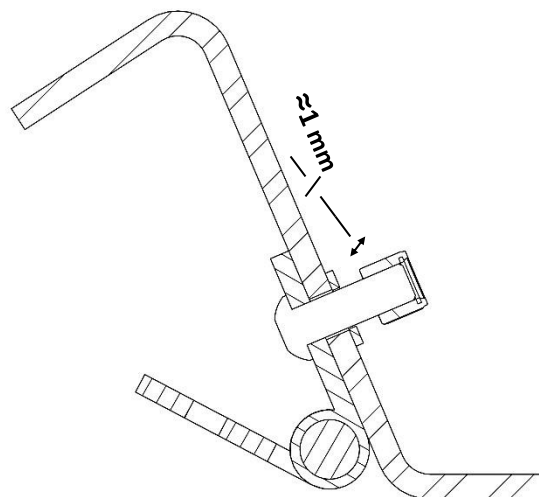
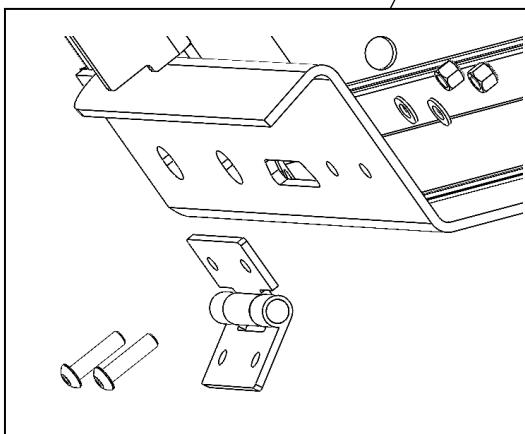

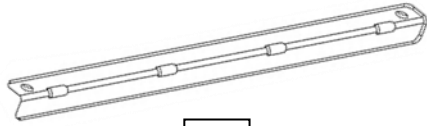

x1

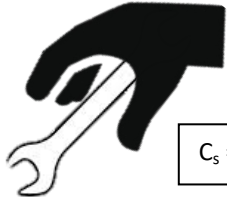

$C_s = 16 \text{ Nm}$



X2 BHC M8x20

Outside



X2 M8 Plastic

Inside



X2 M8



X2 M8

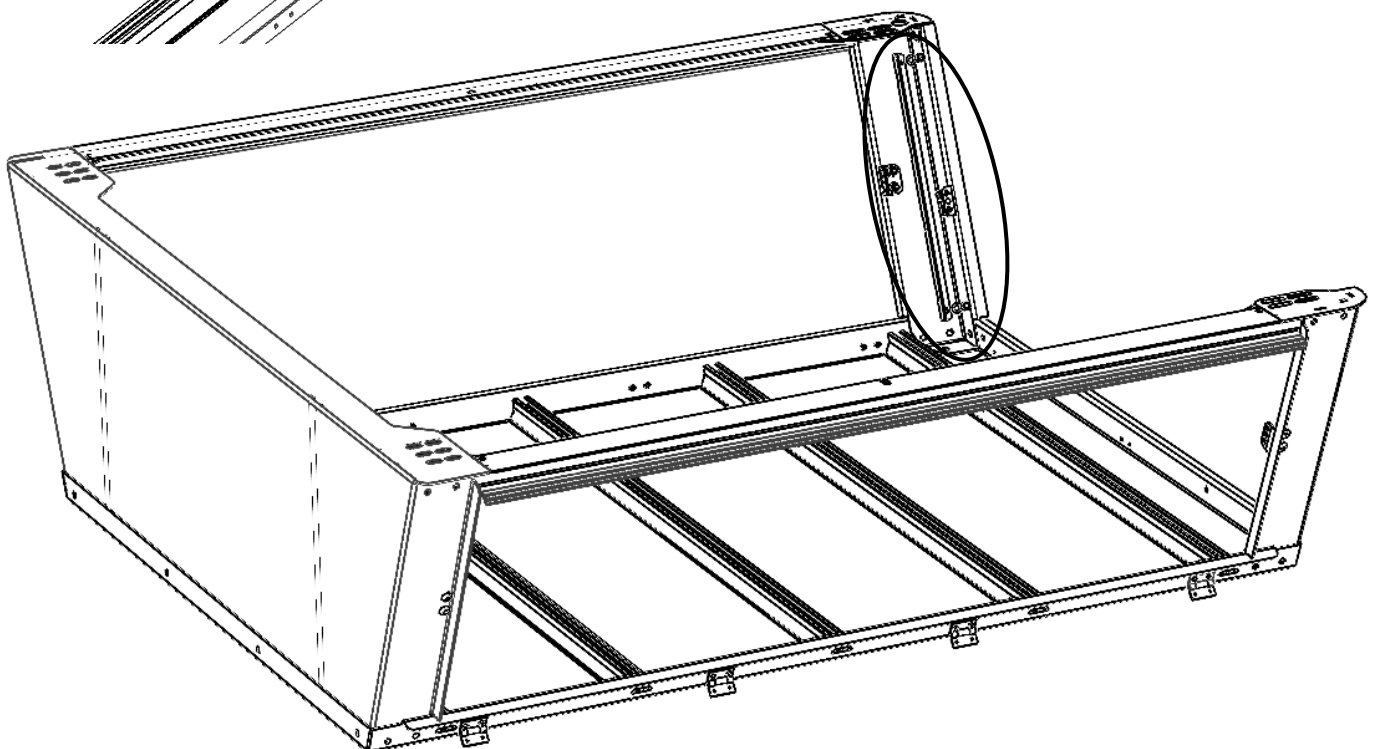
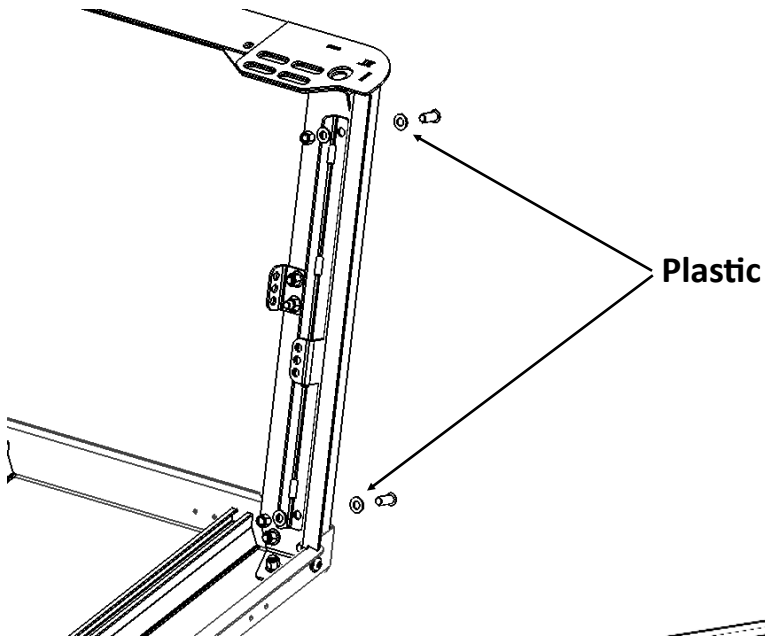

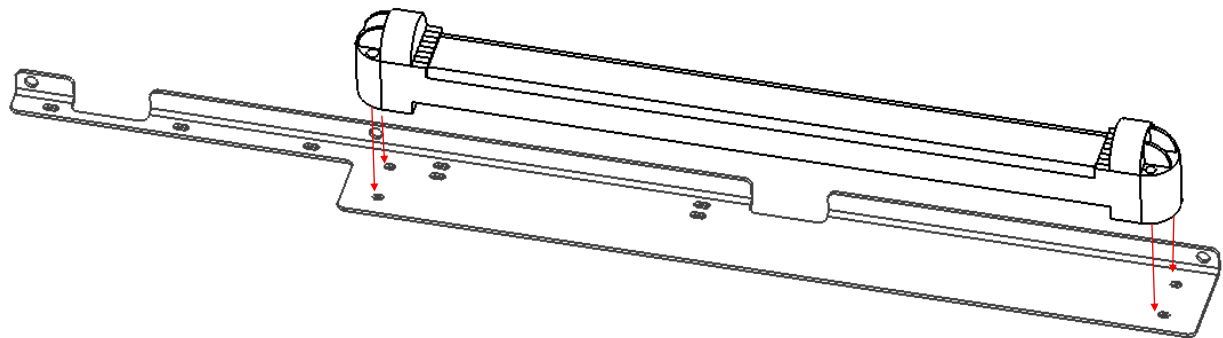
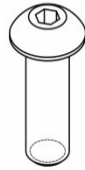
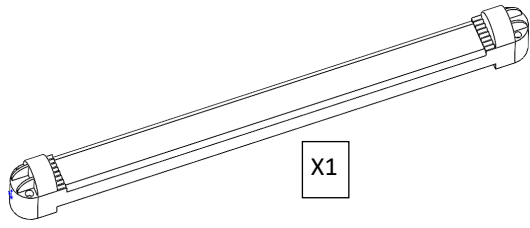

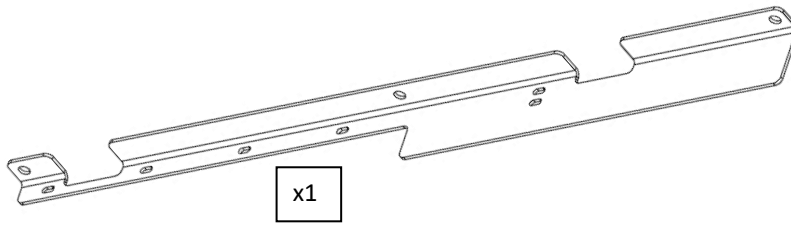

x1



X3 BHC M8x20

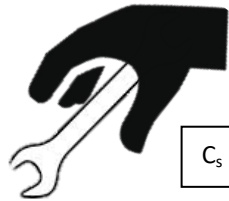

$C_s = 16 \text{ Nm}$

Outside



X3 M8 Plastic

Inside



X3 M8



X3 M8

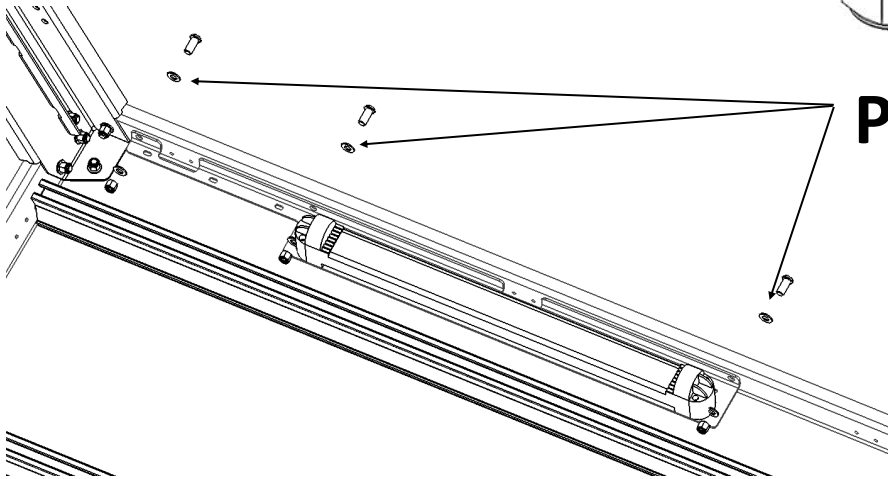

Plastic

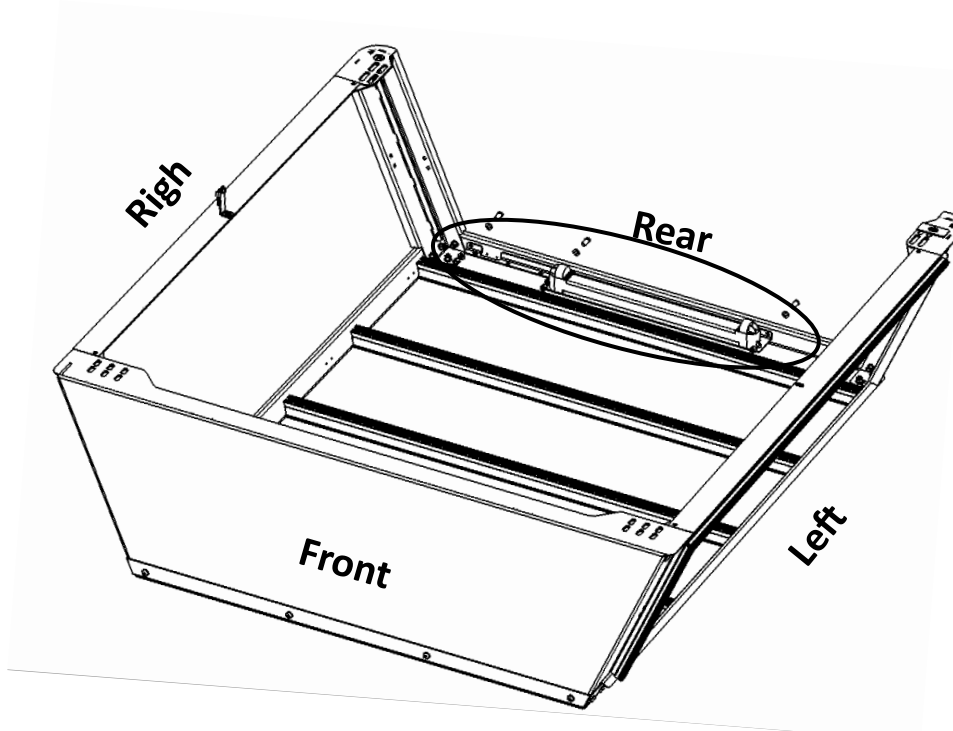

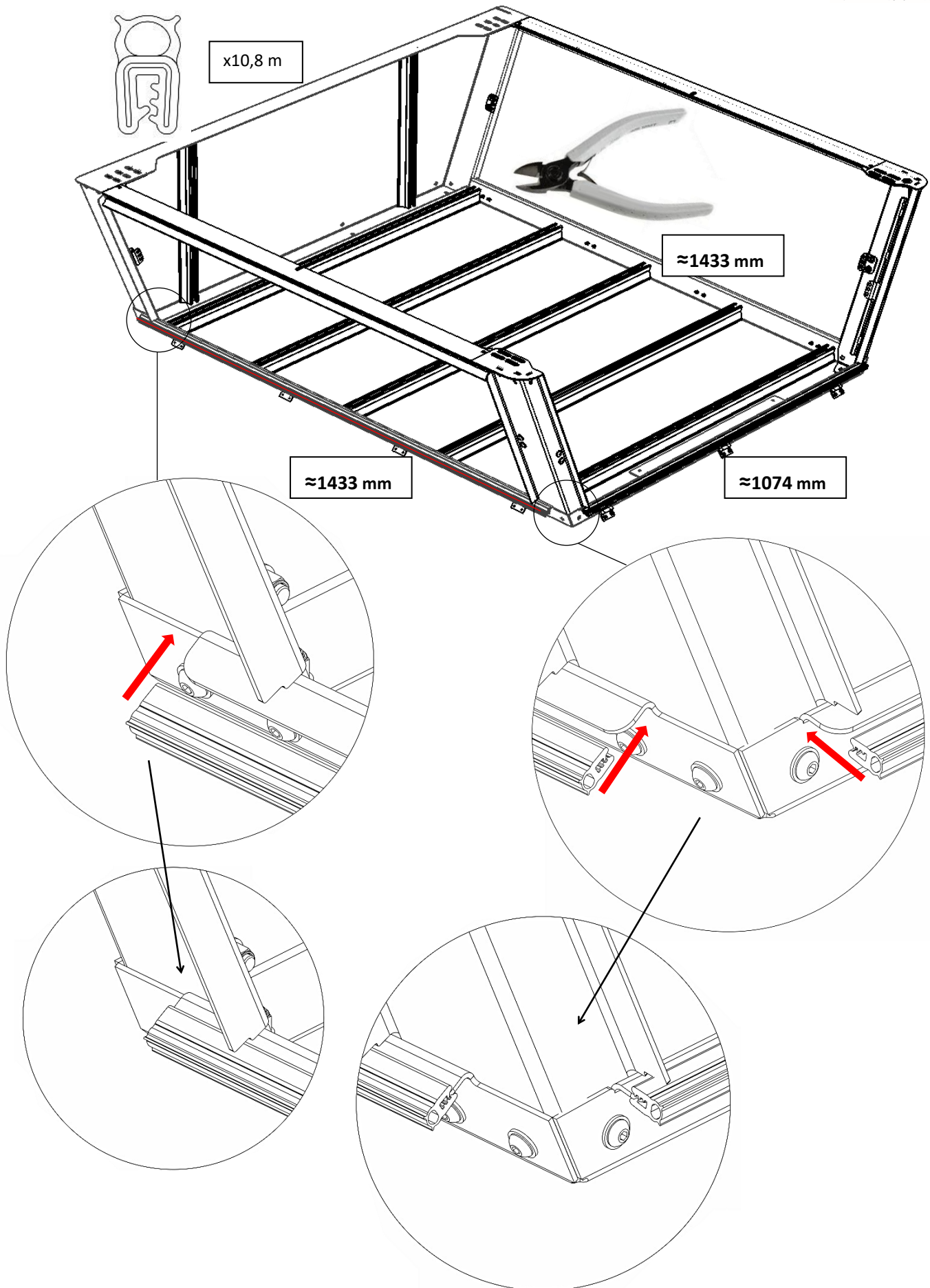

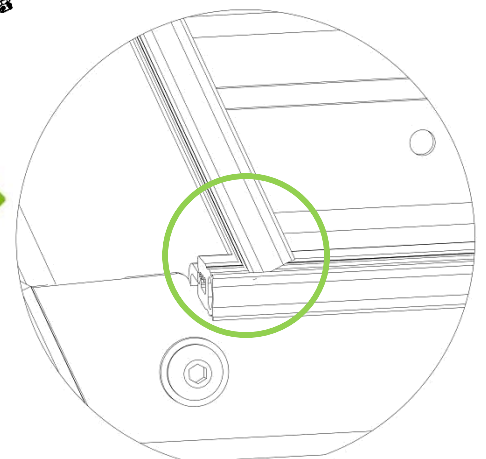
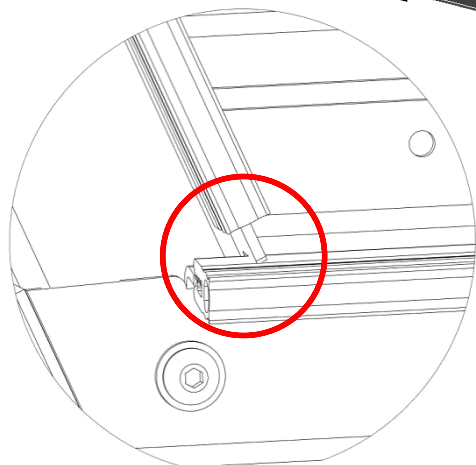
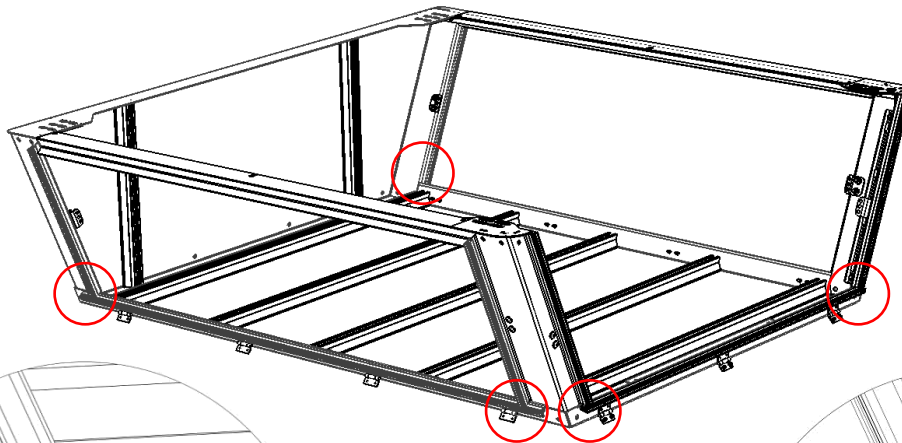
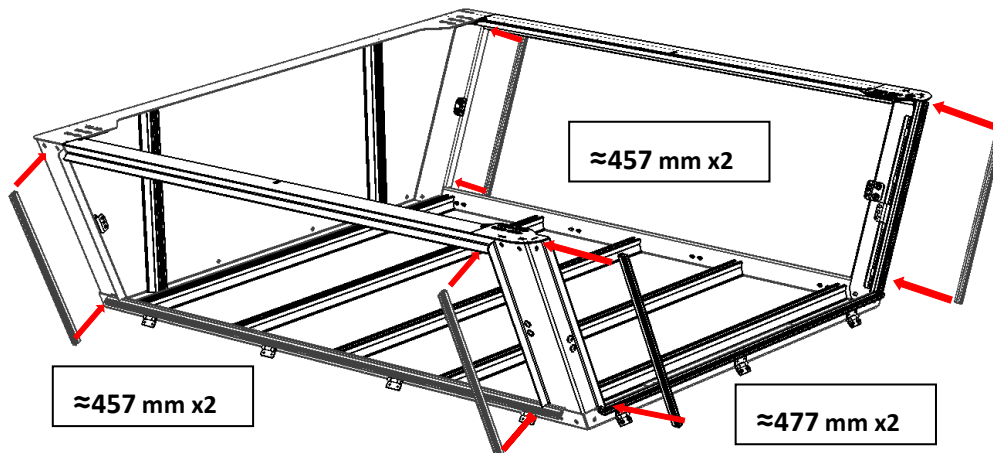
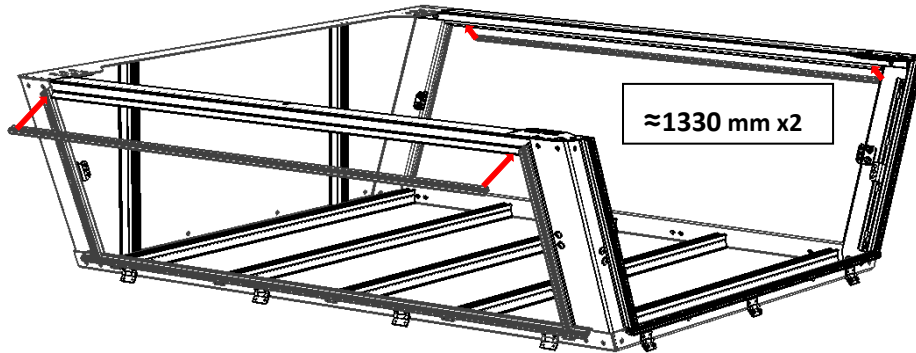

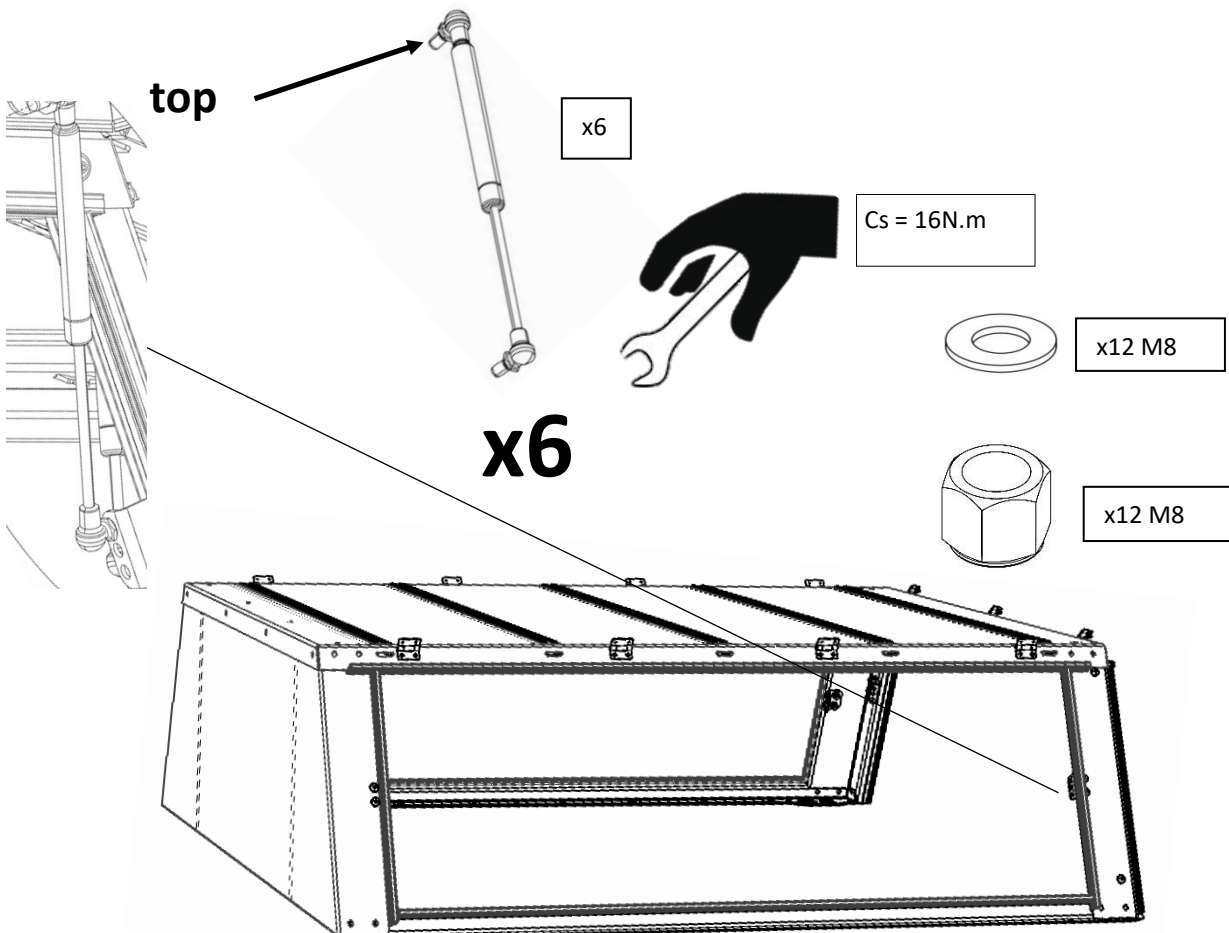
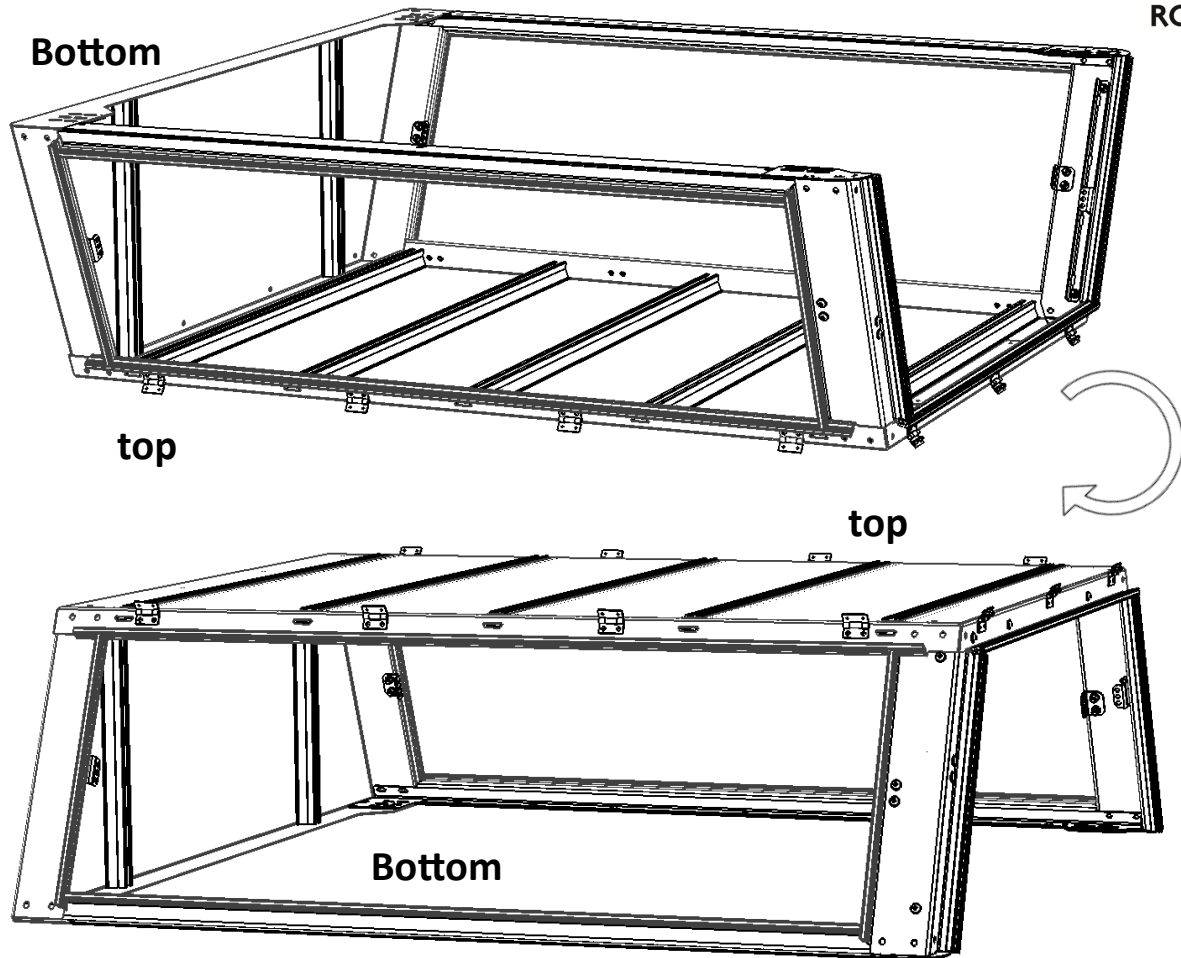

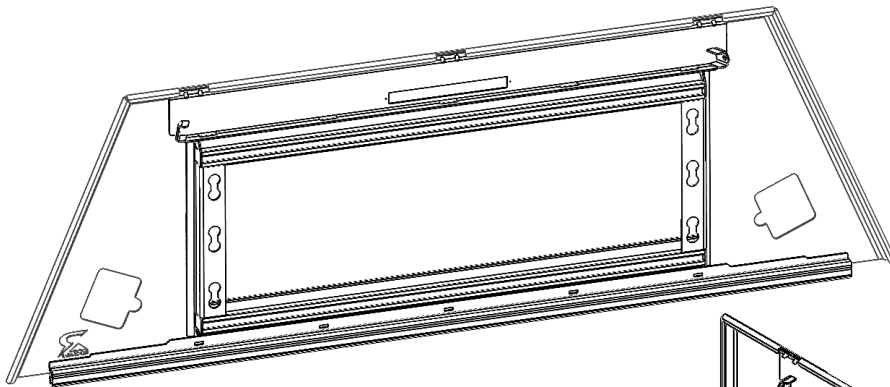

X22 M4

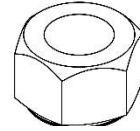

X22 M4

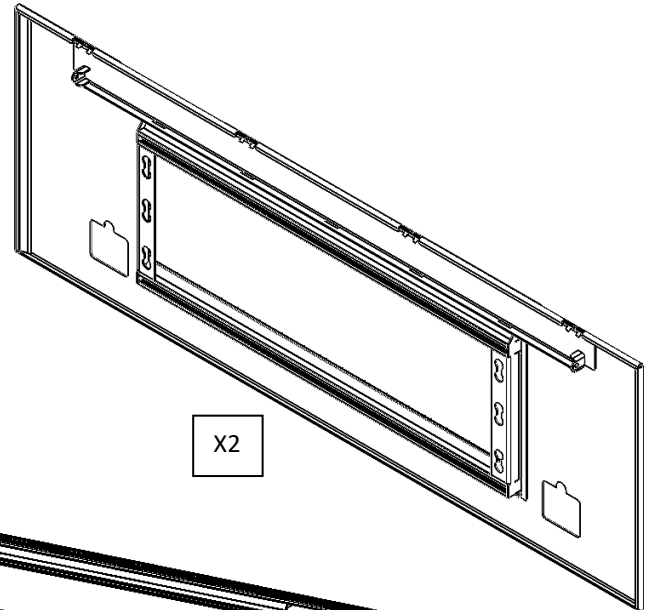
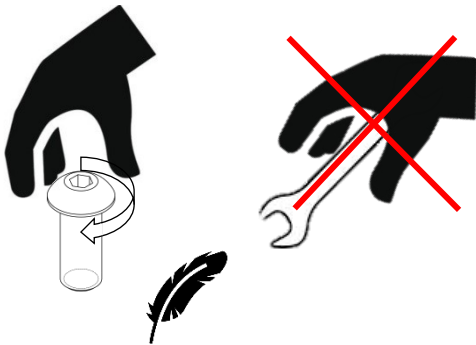

X2

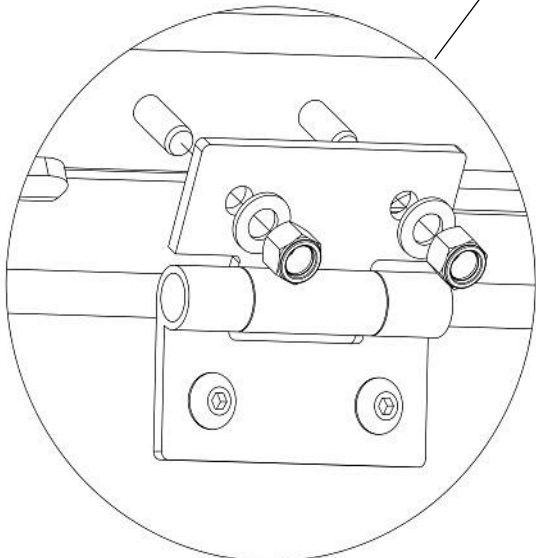
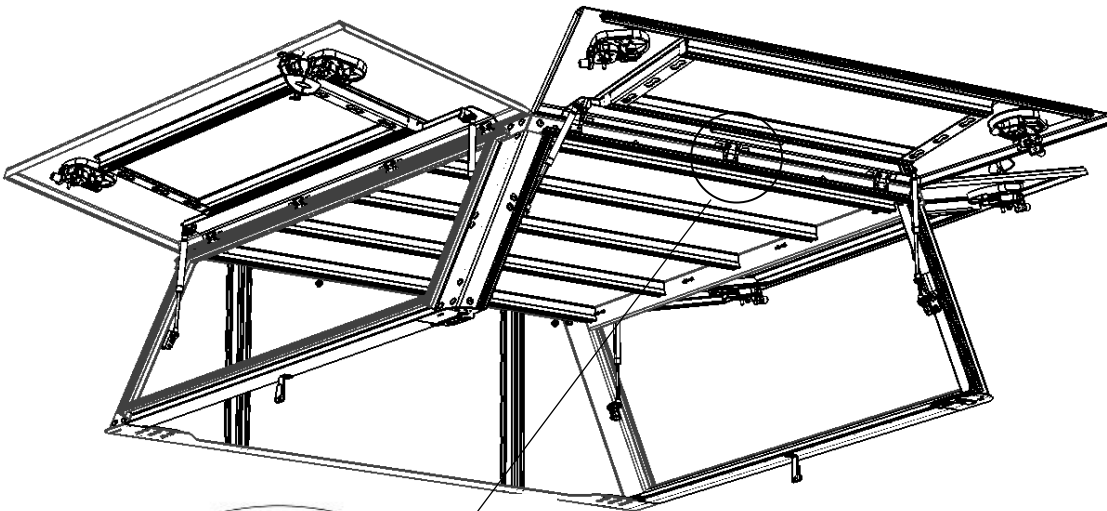

x11

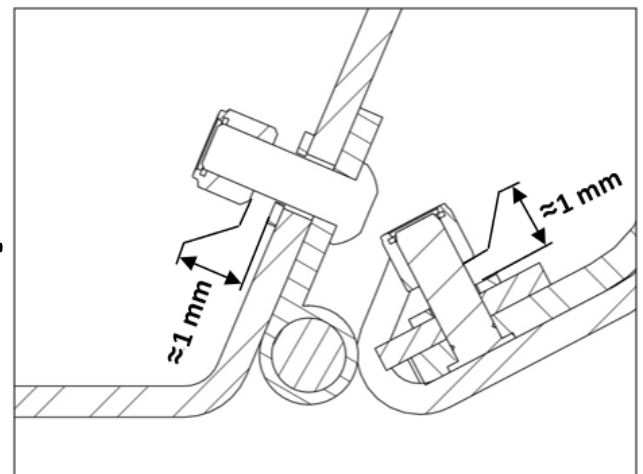

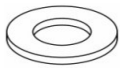
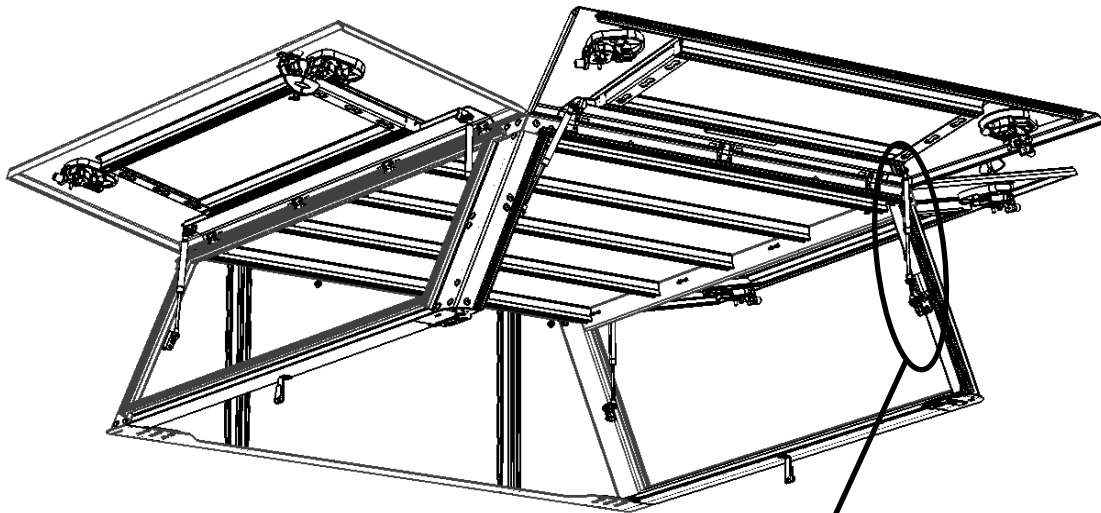

x12 M8

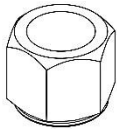

x12 M8

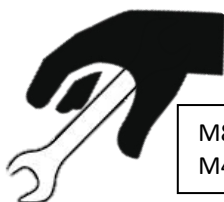
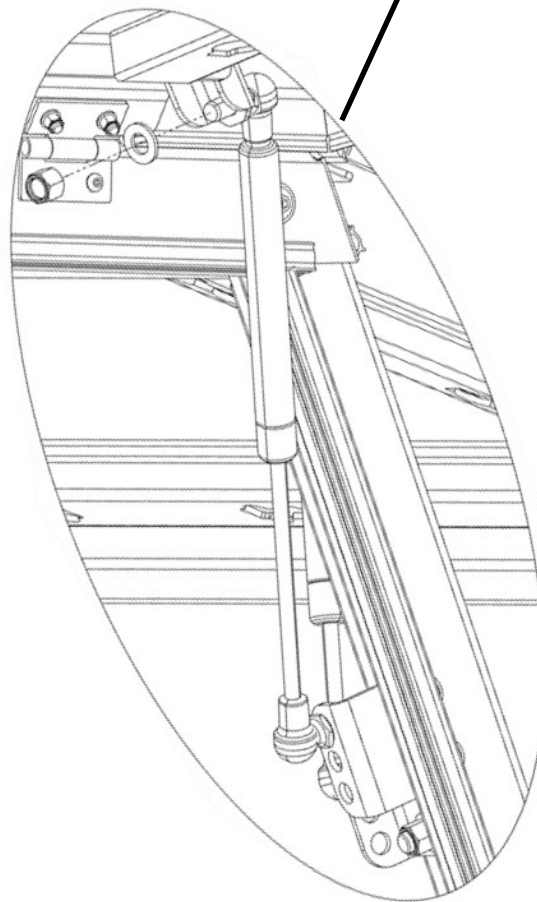

M8 : $C_s = 16 \text{ Nm}$
M4 : $C_s = 3 \text{ Nm}$

ALL SCREWS

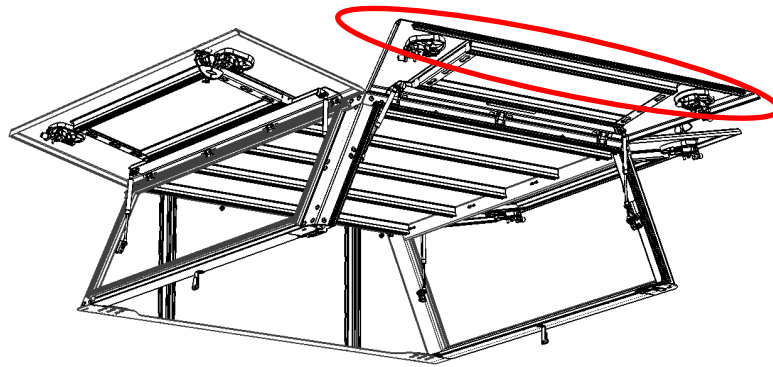

x1,5 m

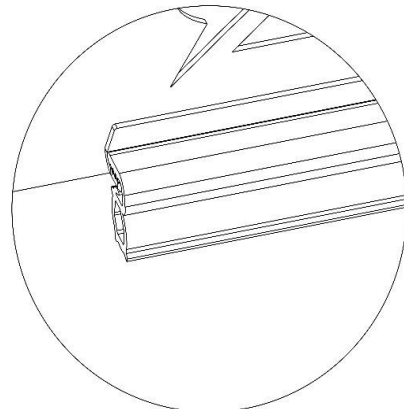
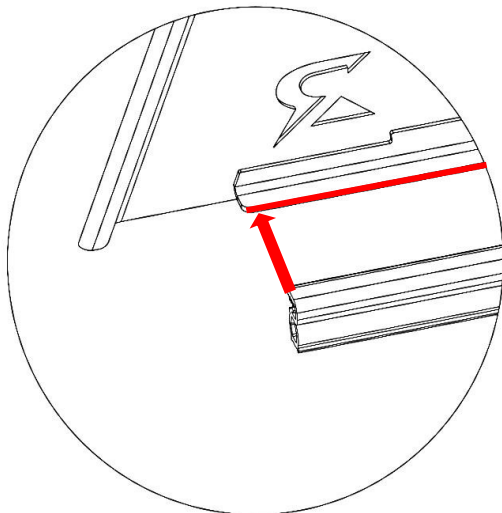
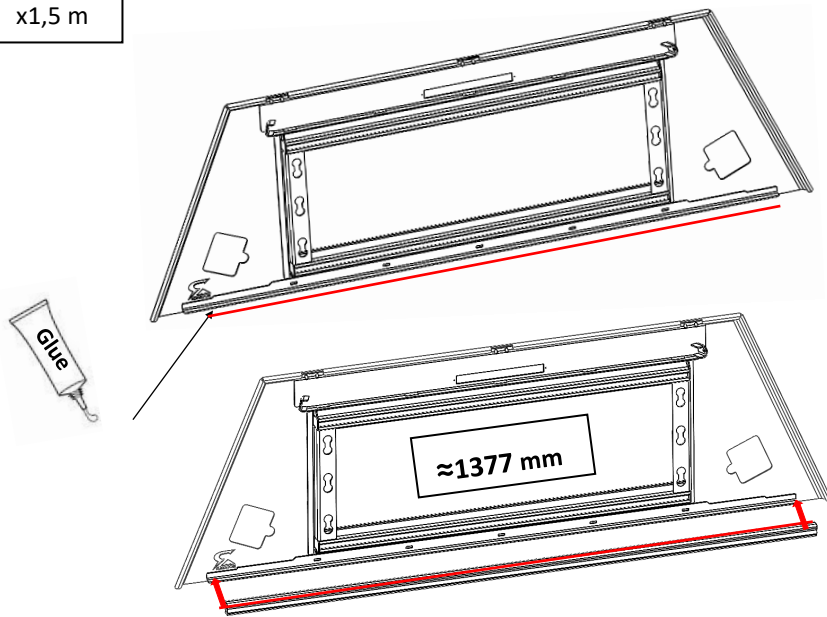

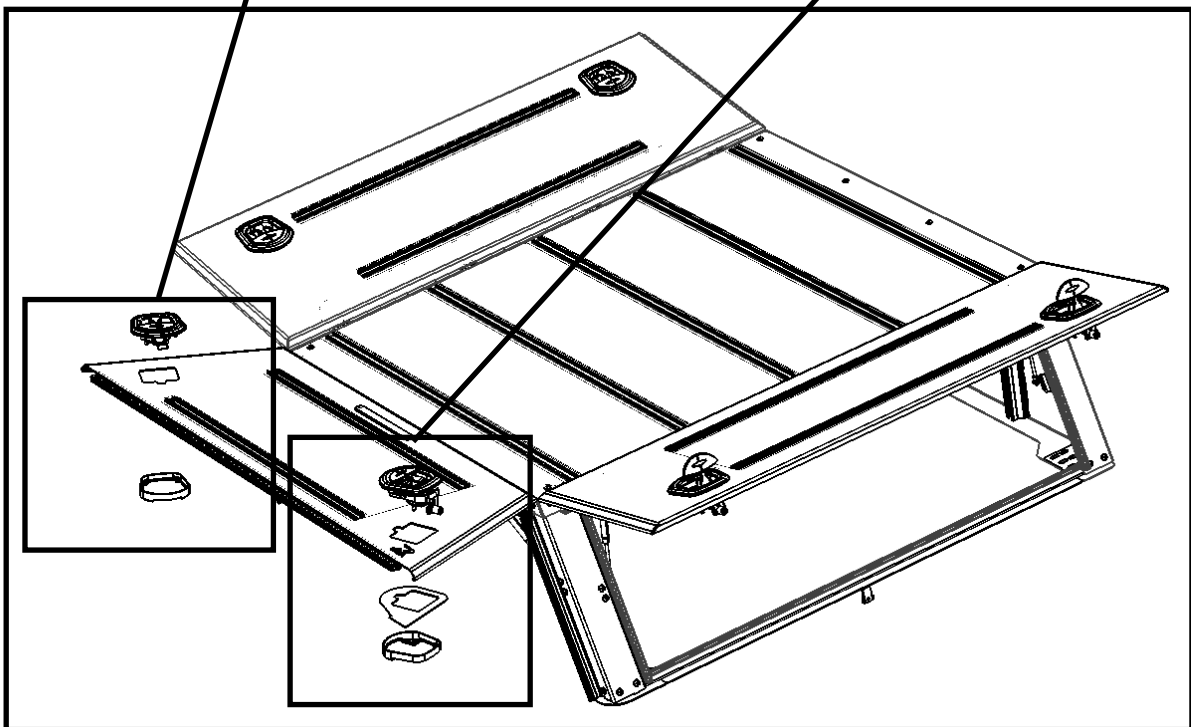
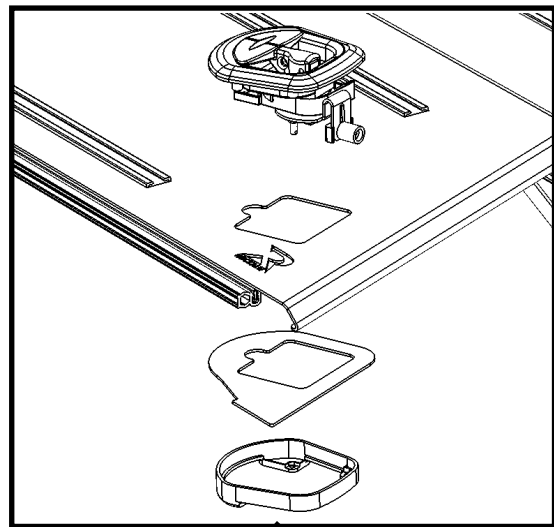
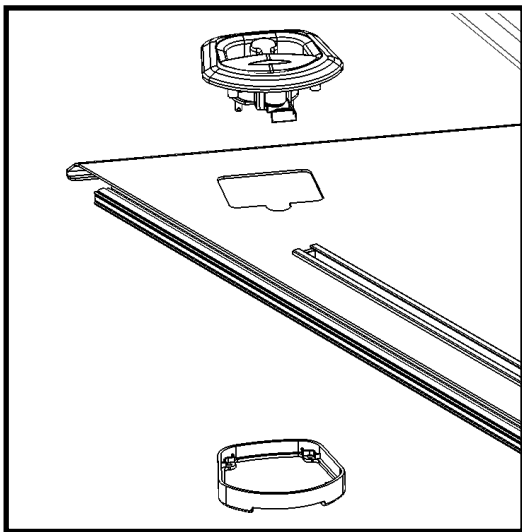
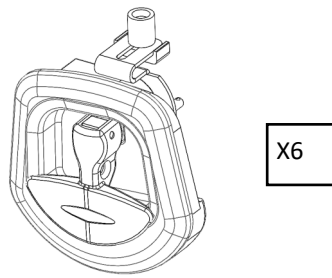
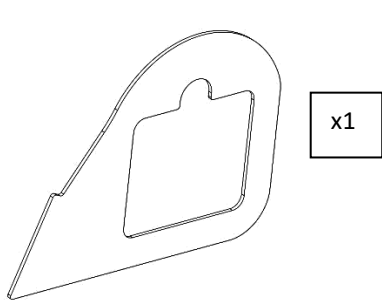

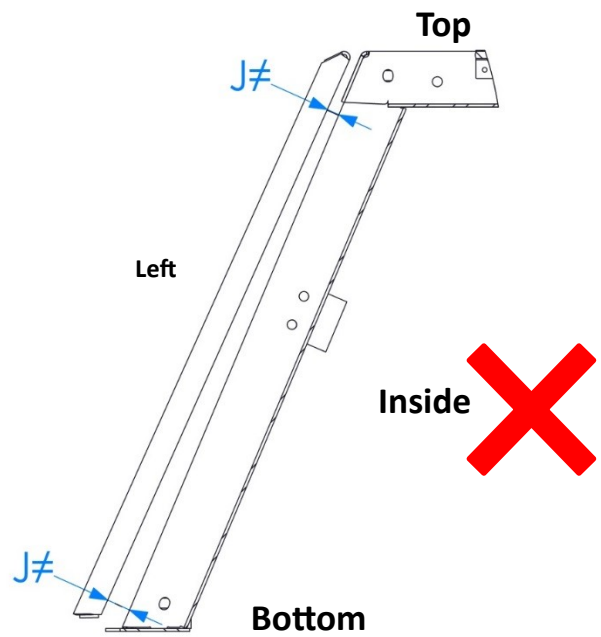
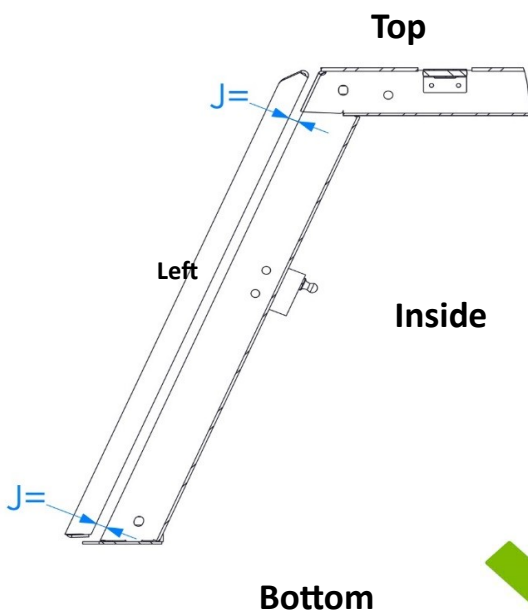
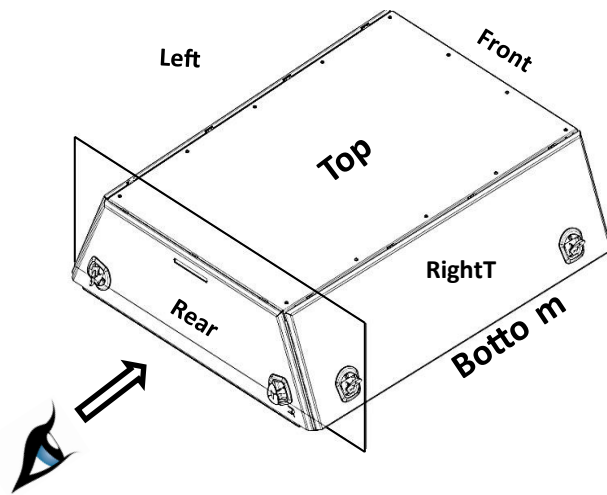
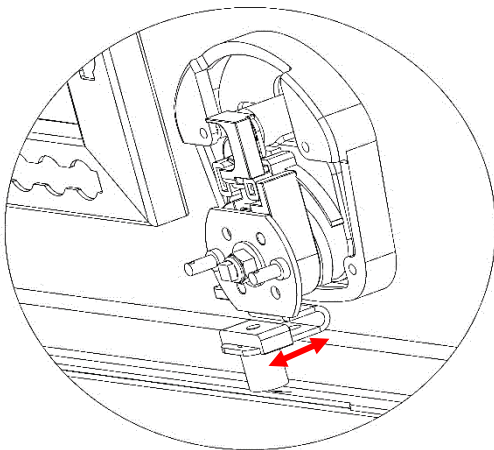
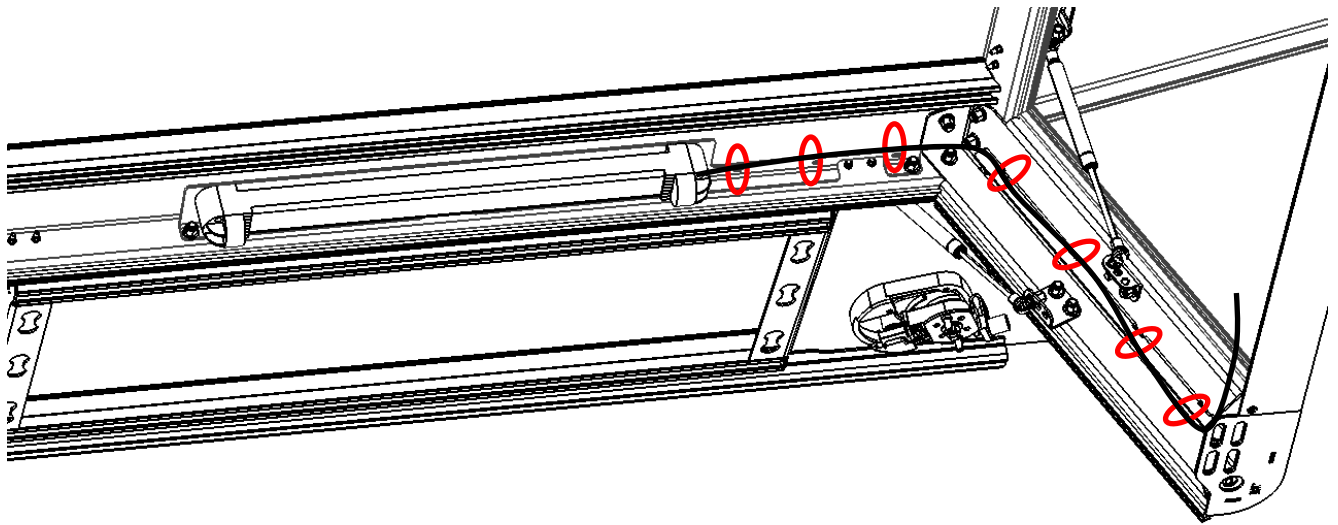

Option :



ONLY FOR :

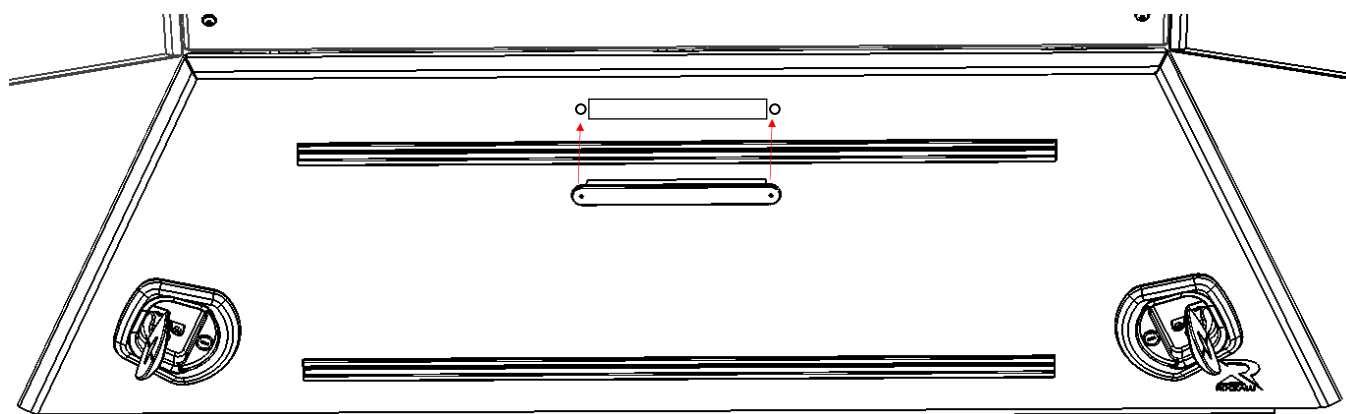
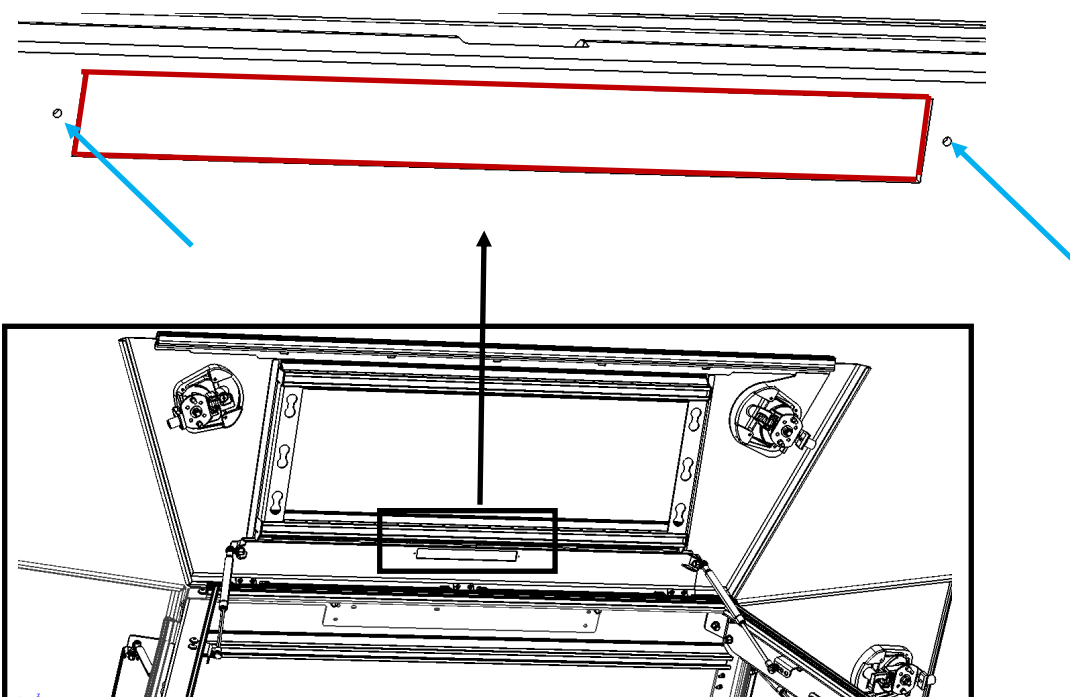
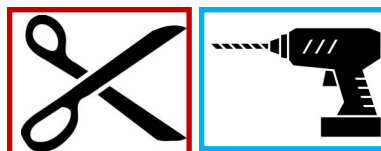
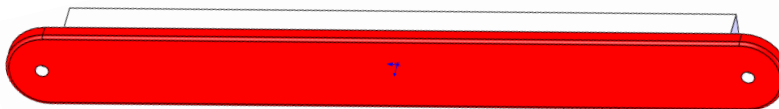

ASSEMBLY



AWNING BRACKET

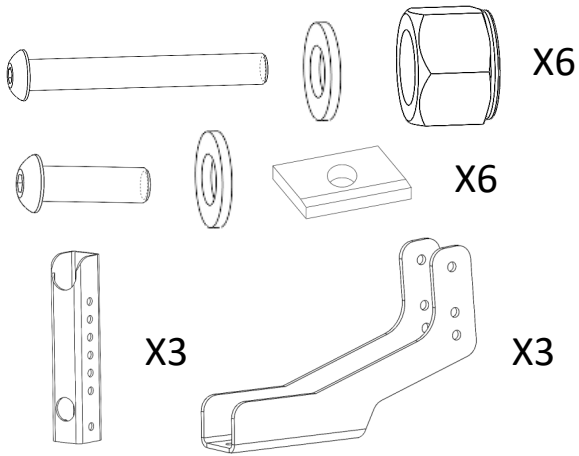

ROOFTOP TENT BRACKET

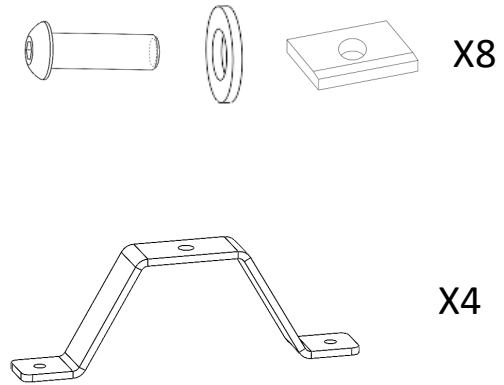

AWNING BRACKET

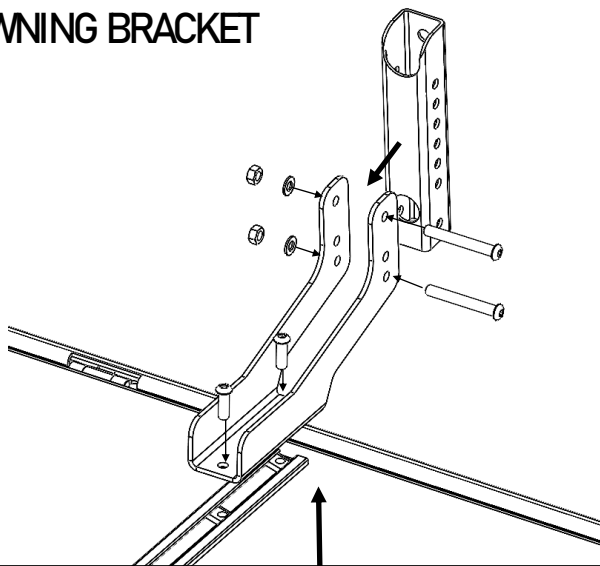

ROOFTOP TENT BRACKET

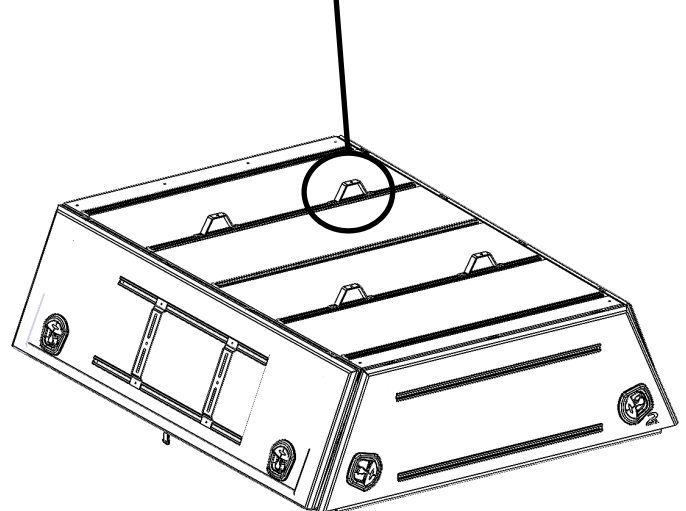
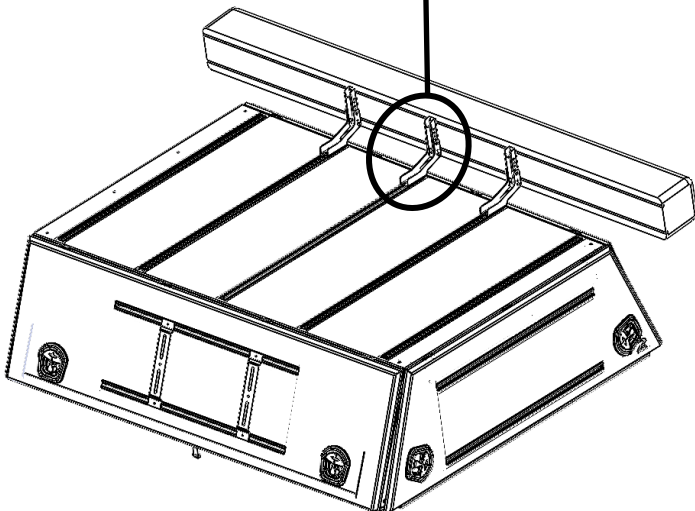
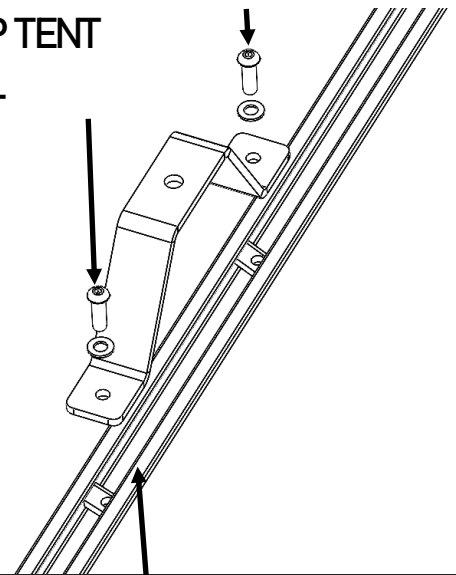

ACCESSORIES BRACKET

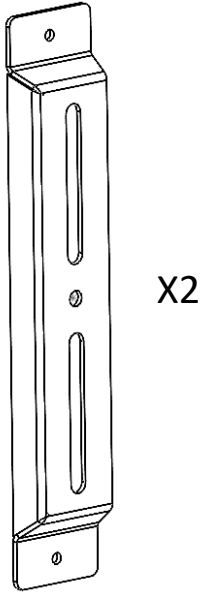
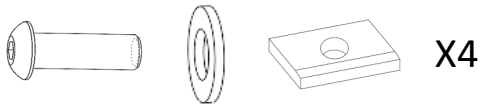

FRONT OF VEHICLE

