

Net weight: 54,00 kg
 Gross weight: 89,00 kg
 Volume: 0 m3

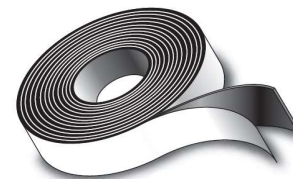
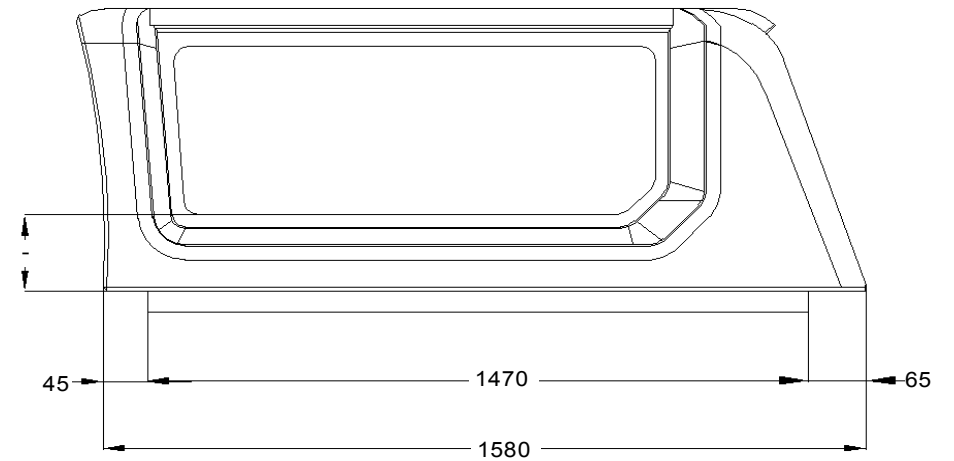
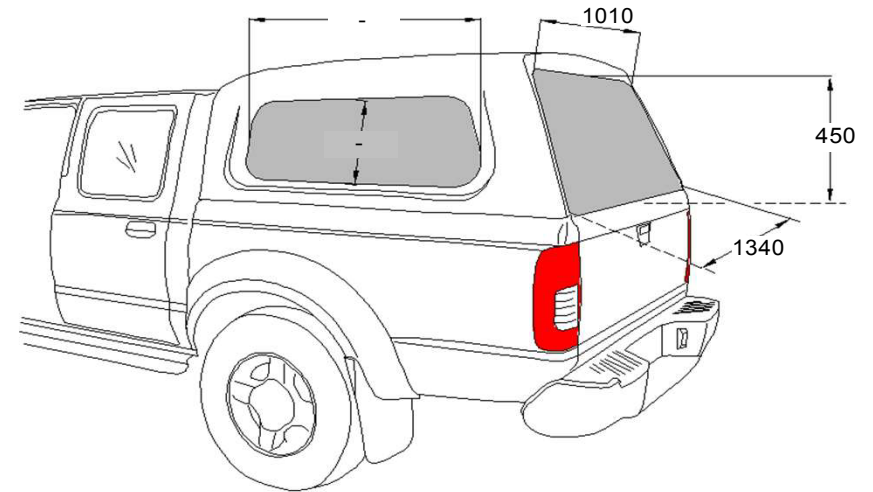

7 X 30 X 10000 A/60/PT3 PE-L - 0,5 szt

IS DC RH03 FLAK - 1900726

Wymiary nadbudowy samochodowej - Dimensions of hardtop

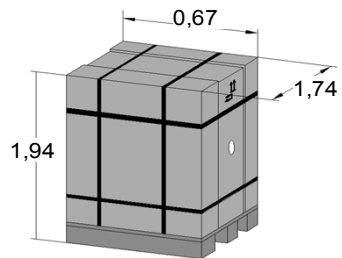
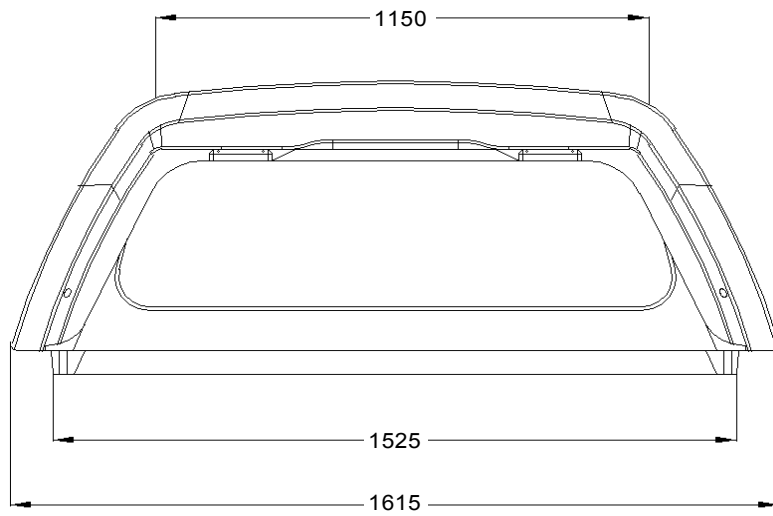
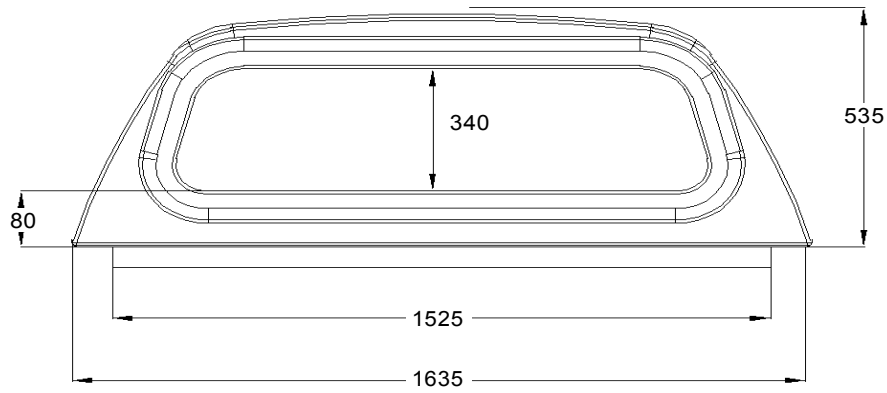

Net weight: 58,00 kg
 Gross weight: 92,00 kg
 Volume: 0 m³

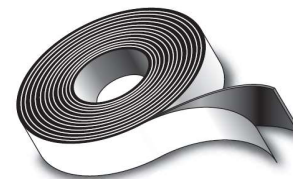
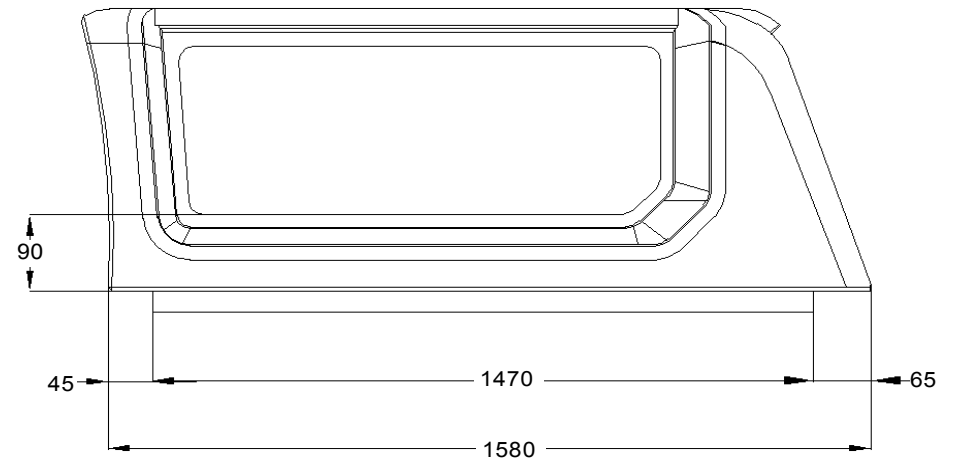
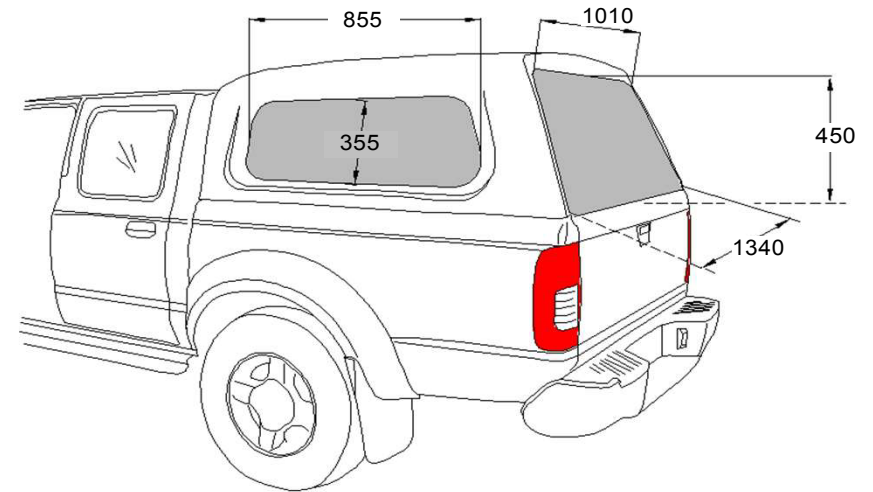

7 X 30 X 10000 A/60/PT3 PE-L - 0,5 szt

IS DC RH03 S2 LAK - 1900728

Wymiary nadbudowy samochodowej - Dimensions of hardtop

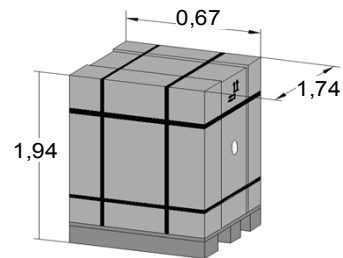
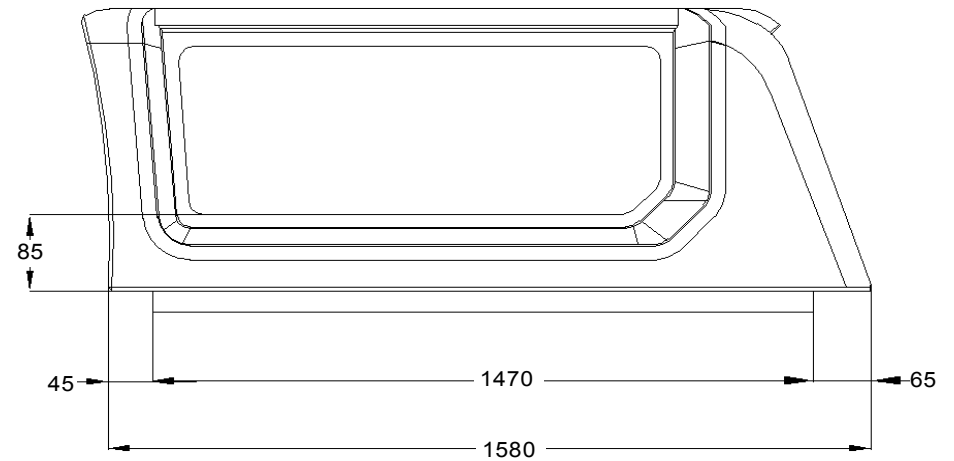
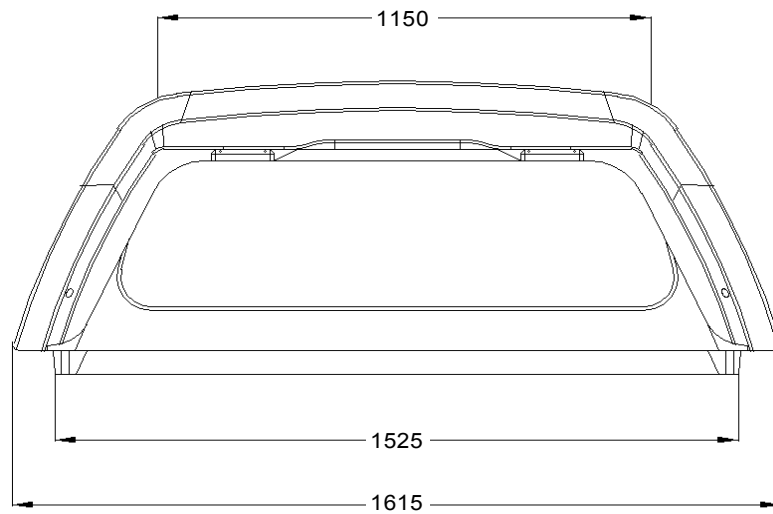
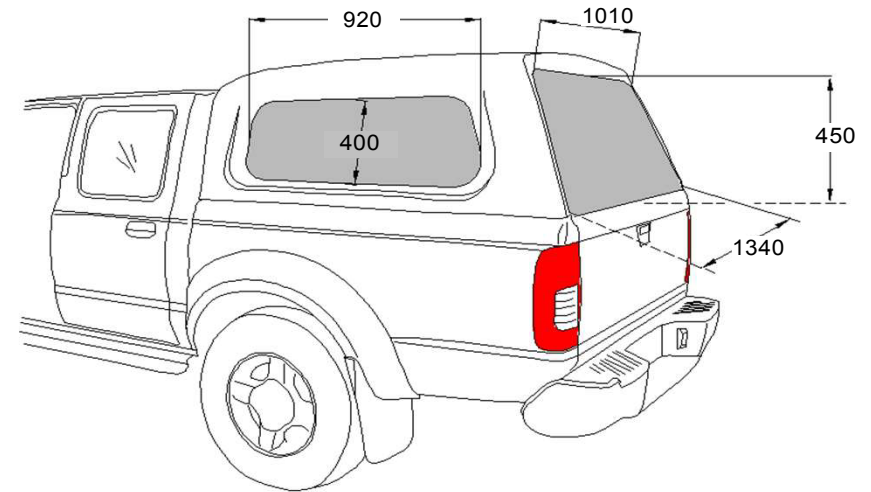
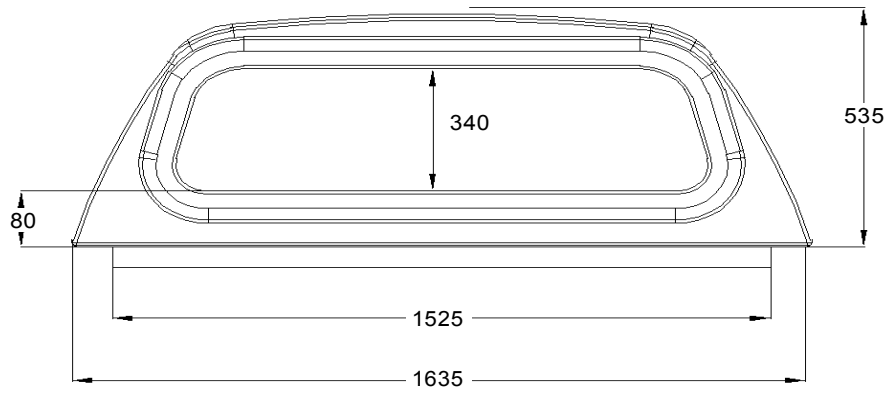

Net weight: 66,00 kg
 Gross weight: 100,00 kg
 Volume: 0 m³

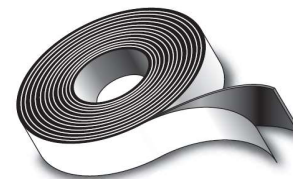

7 X 40 X 10000 A/60/PT3 PE-L - 0,33 szt
 7 X 30 X 10000 A/60/PT3 PE-L - 0,165 szt